

INFORMATION TO USERS

This manuscript has been reproduced from the microfilm master. UMI films the text directly from the original or copy submitted. Thus, some thesis and dissertation copies are in typewriter face, while others may be from any type of computer printer.

The quality of this reproduction is dependent upon the quality of the copy submitted. Broken or indistinct print, colored or poor quality illustrations and photographs, print bleedthrough, substandard margins, and improper alignment can adversely affect reproduction.

In the unlikely event that the author did not send UMI a complete manuscript and there are missing pages, these will be noted. Also, if unauthorized copyright material had to be removed, a note will indicate the deletion.

Oversize materials (e.g., maps, drawings, charts) are reproduced by sectioning the original, beginning at the upper left-hand corner and continuing from left to right in equal sections with small overlaps. Each original is also photographed in one exposure and is included in reduced form at the back of the book.

Photographs included in the original manuscript have been reproduced xerographically in this copy. Higher quality 6" x 9" black and white photographic prints are available for any photographs or illustrations appearing in this copy for an additional charge. Contact UMI directly to order.

UMI

A Bell & Howell Information Company
300 North Zeeb Road, Ann Arbor MI 48106-1346 USA
313/761-4700 800/521-0600

**PAVEMENT AND BRIDGE COST ALLOCATION ANALYSIS
OF THE
ONTARIO INTERCITY HIGHWAY NETWORK**

by

Mohammad Reza Ghaeli

A thesis presented to the University of Waterloo
in fulfillment of the
thesis requirement for the degree of
Doctor of Philosophy
in
Civil Engineering

Waterloo, Ontario, Canada, 1997

© Mohammad Reza Ghaeli 1997



National Library
of Canada

Bibliothèque nationale
du Canada

Acquisitions and
Bibliographic Services

Acquisitions et
services bibliographiques

395 Wellington Street
Ottawa ON K1A 0N4
Canada

395, rue Wellington
Ottawa ON K1A 0N4
Canada

Your file *Votre référence*

Our file *Notre référence*

The author has granted a non-exclusive licence allowing the National Library of Canada to reproduce, loan, distribute or sell copies of this thesis in microform, paper or electronic formats.

L'auteur a accordé une licence non exclusive permettant à la Bibliothèque nationale du Canada de reproduire, prêter, distribuer ou vendre des copies de cette thèse sous la forme de microfiche/film, de reproduction sur papier ou sur format électronique.

The author retains ownership of the copyright in this thesis. Neither the thesis nor substantial extracts from it may be printed or otherwise reproduced without the author's permission.

L'auteur conserve la propriété du droit d'auteur qui protège cette thèse. Ni la thèse ni des extraits substantiels de celle-ci ne doivent être imprimés ou autrement reproduits sans son autorisation.

0-612-30611-9

Canada

I hereby declare that I am the sole author of this thesis.

I authorize the University of Waterloo to lend this thesis to other institutions or individuals for the purpose of scholarly research.

A handwritten signature in cursive script, appearing to read "M. R. Ghosh".

I further authorize the University of Waterloo to reproduce this thesis by photocopying or by other means, in total or in part, at the request of other institutions or individuals for the purpose of scholarly research.

A second handwritten signature in cursive script, identical to the one above, appearing to read "M. R. Ghosh".

The University of Waterloo requires the signature of all persons using or photocopying this thesis. Please sign below, and give address and date.

ABSTRACT

Transportation infrastructure investments have important economic benefits for society and require a significant amount of public expenditure. Canadian road infrastructure carries more than 85% of total trips and consumes several billion dollars every year. Federal and provincial governments are responsible for providing the public with road services while trying to keep costs and taxes down. Hence, there is a pressing need to recover the road expenses by directly charging the road users in a rational way. The user charges, however, must be acceptable and direct the demand for road services in order to achieve an efficient utilization of the road infrastructure.

The objectives of this research are to examine the economic characteristics of the pavements and bridges of the Ontario inter-city highway network, to improve the procedures for cost allocation analysis, to calculate the rational road charges that should be levied on different vehicle types, and to analyze the effects of road prices and different pricing schemes on road users. These goals are achieved through a comprehensive analysis of pavement and bridge costs in Ontario based on the OPAC 2000 pavement performance models as well as some bridge cost estimation models and an innovative game-theoretic cost allocation approach developed in this research.

Significant differences are observed between cost characteristics of pavements with different subgrade and traffic conditions and in different locations of Ontario. Due to harsher climate in Northern Ontario pavement life-cycle costs are 6 to 15 percent higher than those in Southern Ontario. The life-cycle costs of optimally designed pavements with weak subgrades may be more than 60 percent higher than those with strong subgrades for the same location and traffic conditions. The cost analysis of Ontario pavements also implies that up to 70 percent of the deterioration of optimally designed pavements is due to environment-induced damage. Large differences are found between the pavement damages imposed by commercial trucks and passenger cars. The damage imposed by an overloaded truck trailer operating on a low volume road is estimated at about \$1.61/km while an automobile operating on the same road imposes about \$0.00000015/km. The overall life-cycle cost of the pavements in this study is estimated to be \$2.18 billion. However, if the pavements were designed for automobile loads, that figure would be \$1.38 billion. Hence, the large differences between the marginal cost of road use by commercial trucks and passenger cars do not justify the allocation of road charges to different road users in the same proportion of their marginal costs, since some of the road costs are common costs and roads are primarily designed to withstand truck loads.

The bridge cost analysis shows that the major element of bridge life-cycle cost is the initial capital cost of construction. The deterioration of bridges is largely due to environmental factors and deicing chemicals and maintenance costs are less than 0.2% of the initial construction costs. The bridge construction cost can be estimated at about \$1000/m² (present worth) on average for most of the Ontario bridges. It is identified that the total bridge cost is about 14 percent of total road construction and maintenance costs in Ontario. The present worth of bridge construction costs for the bridge samples in the analysis database is estimated to be \$10.8 billion, while this figure would be reduced to \$5.5 billion if bridges were designed for automobile loads exclusively.

A new cost allocation procedure is developed based on the concepts of cooperative game theory. A set of rational relationships between vehicle costs and charges are established to reflect full road cost recovery and to ensure that no vehicle or group of vehicles is charged less than its marginal cost or more than its stand-alone cost. The game-theoretic approach provides flexibility, integrity, and transparency in observing the details of costs and prices under different road or taxation policies. On average across Ontario, the highest road fee for low and medium payload levels (1t to 30t) has been assigned to 3 and 4 axle semitrailers at \$0.05 /km followed by heavy haul A and B-trains at \$0.04 /km, 5+ axle semitrailers as well as 2 and 3 axle B-Trains at \$0.03 /km, single unit trucks (for 1t to 10t payload range) as well as single to tridem semitrailers at \$0.02 /km, and truck trailers at \$0.01 /km. For heavier payloads of more than 30t the highest road fee has been allocated to 3 and 4 axle semitrailers at \$0.37 /km followed by truck trailers at \$0.24 /km, 2 and 3 axle B-Trains at \$0.20 /km, 5+ axle semitrailers at \$0.19 /km, and heavy haul A and B-trains at \$0.16 /km.

The research also shows that vehicle operating costs dominate the total road user costs, limiting the effect of pricing strategies on efficient selection of vehicle type and payload level. The average vehicle operating cost is about \$0.85 /km, while the average road fee for trucks calculated in this research is about \$0.06 /km. It is also observed that if a complex pricing scheme through which vehicles are charged exactly the suggested game-theoretic prices were implemented, and if users reacted to such a pricing scheme in the most efficient way then the total savings in pavement life-cycle costs would be about 6 percent. It is concluded that the pricing tools may not be effective in directing the utilization of the road facilities to the most desirable level unless the collected fees are set above the total system costs or if vehicle weight regulations are strictly enforced. However, proper pricing and taxation strategies can result in optimal selection of vehicles and would result in more efficient utilization of vehicle types.

ACKNOWLEDGMENTS

I wish to express my sincere thanks to Professor Bruce Hutchinson, my supervisor, for his guidance, support and words of advice throughout this research. I also would like to express my gratitude to Professor David Gillen and Professor Ralph Haas, my co-supervisors, for their help and feedback during my Ph.D. program. I consider it a privilege and honor to know them and to work with them.

I would like to extend my thanks to Paul Fernando, Susan Teigh and Brij Sharma in the Ministry of Transportation of Ontario for providing me with bridge and pavement data in Ontario.

My acknowledgments are also given to my colleagues, specially Donath Mrawira, Michel Huot, Saad Nasar and Ziewei He for their support and time whenever I needed to discuss my ideas with someone. I am specially grateful to Wei who developed the OPAC 2000 model and provided me with lots of information about pavement performance modelling; and Michel for always being there for me and for his advice to improve my self-confidence.

I wish to express my gratitude to my loving family. I am grateful to my wife, Nazanin, for her patience, endurance and love. She sacrificed the best times of her life and accepted living under student condition to allow me to reach to my goals. Also, thanks to my sister, Padideh, for her moral and financial support. Whenever I was lost, she was the first one to help me with her wisdom and moral support. Also, I wish to express my deepest appreciation to my mother, Fakhri, and my father, Houshang, for their support, encouragement and prayers. I am indebted to all of them.

To my parents, Fakhri and Houshang;

To my loving wife, Nazanin;

To my sister, Padideh;

with love

TABLE OF CONTENTS

CHAPTER 1: INTRODUCTION	1
1.1. ROAD COSTS AND REVENUE POLICIES IN CANADA.....	1
1.2. COST ALLOCATION ANALYSIS IN CANADA.....	4
1.3. GENERAL ISSUES IN HIGHWAY COST ALLOCATION ANALYSIS	5
1.4. PROBLEM DEFINITION AND RESEARCH OBJECTIVES	7
1.5. THESIS ORGANIZATION.....	8
CHAPTER 2: BACKGROUND AND RESEARCH METHODOLOGY	10
2.1. INTRODUCTION.....	10
2.2. ROAD PRICING THEORY	11
2.2.1. <i>Goals of Cost Allocation Analysis</i>	11
2.2.2. <i>Cost Elements in Road Networks</i>	12
2.2.3. <i>Review of Cost Curves</i>	13
2.2.4. <i>Review of Pricing Methods</i>	15
2.3. CHARGING INSTRUMENTS	21
2.4. PHYSICAL BEHAVIOUR OF PAVEMENTS AND BRIDGES	24
2.4.1. <i>Pavements</i>	24
2.4.2. <i>Factors Affecting Pavement Performance</i>	28
2.4.3. <i>Bridges</i>	30
2.5. RESEARCH APPROACH AND METHODOLOGY	30
2.5.1. <i>General Framework</i>	30
2.5.2. <i>Pavement Cost Analysis Submodule</i>	32
2.5.3. <i>Bridge Cost Analysis</i>	33
2.5.4. <i>Charging Structure Module</i>	34
CHAPTER 3: ANALYSIS OF FLEXIBLE PAVEMENTS IN ONTARIO	37
3.1. INTRODUCTION.....	37
3.2. PAVEMENT STRUCTURES	37
3.2.1. <i>Pavement Layers and Materials</i>	37
3.2.2. <i>Mechanics of Flexible Pavement Behaviour</i>	39
3.2.3. <i>Initial Pavement Design Process</i>	40
3.3. THE OPAC 2000 PAVEMENT PERFORMANCE MODEL.....	42
3.3.1. <i>The Structure of the OPAC 2000 Model</i>	42
3.3.2. <i>Load Equivalency Factors</i>	47
3.4. PAVEMENT LIFE-CYCLE COSTS	48
3.5. FRAMEWORK AND ASSUMPTIONS OF PAVEMENT COST ANALYSIS ..	49
3.5.1. <i>Framework of Cost Analysis</i>	49
3.5.2. <i>Characteristics of Ontario Pavements</i>	52
3.6. COST EVALUATION OF ONTARIO PAVEMENTS USING OPAC 2000.....	54
3.6.1. <i>Analysis Goals</i>	54
3.6.2. <i>Optimal Pavement Designs</i>	55

CHAPTER 4: MARGINAL PAVEMENT COSTS IN ONTARIO	67
4.1. INTRODUCTION.....	67
4.2. DESCRIPTION OF THE DATA BASES.....	68
4.3. COST ANALYSIS PROCEDURES.....	69
4.3.3. <i>Design ESALs</i>	72
4.4. DISCUSSION OF THE RESULTS.....	74
4.4.1. <i>Life-Cycle Costs of Different Pavements in Ontario</i>	74
4.5. FREQUENCY DISTRIBUTION OF MARGINAL COSTS.....	82
CHAPTER 5: PAVEMENT COST ALLOCATION ANALYSIS	85
5.1. INTRODUCTION.....	85
5.2. PROPOSED COST ALLOCATION METHOD.....	85
5.2.1. <i>The Mathematical Framework of Cooperative Game Theory</i>	85
5.2.2. <i>Application of Game Theory to Road Cost Allocation</i>	87
5.2.3. <i>Classification of Road Users and Cost Allocation Matrix Cells</i>	89
5.2.4. <i>Formulation of the Game-Theoretic Cost Allocation</i>	91
5.3. COST ALLOCATION MATRIX.....	97
5.3.1. <i>Cell Entries</i>	97
5.3.2. <i>General Characteristics of the Users</i>	107
5.4. COST ALLOCATION RESULTS.....	112
CHAPTER 6: BRIDGE COST ANALYSIS	123
6.1. INTRODUCTION.....	123
6.2. BRIDGE DESIGN CONCEPTS.....	124
6.2.1. <i>General Specifications</i>	124
6.2.2. <i>Design Loads</i>	126
6.2.3. <i>Design Methods</i>	127
6.2.4. <i>Internal Forces</i>	129
6.2.5. <i>Bridge Design Procedure</i>	130
6.3. CHARACTERISTICS OF BRIDGES IN ONTARIO.....	131
6.3.1. <i>General Information</i>	131
6.3.2. <i>Estimation of Bridge Costs</i>	133
6.4. BRIDGE COST ANALYSIS AT NETWORK LEVEL.....	138
6.4.1. <i>General Framework</i>	138
6.4.2. <i>General Results</i>	140
CHAPTER 7: BRIDGE COST ALLOCATION ANALYSIS	144
7.1. INTRODUCTION.....	144
7.2. ANALYSIS FRAMEWORK.....	144
7.3. FORMULATION OF THE PROBLEM.....	153
CHAPTER 8: OPTIMAL ROAD PRICING	161
8.1. INTRODUCTION.....	161
8.2. CHARGING SYSTEM CHARACTERISTICS.....	162
8.3. CHARGING PRINCIPLES.....	165
8.4. IMPLEMENTATION OF A SOUND CHARGING SYSTEM IN ONTARIO.....	166
8.4.1. <i>Theoretical Charges</i>	166
8.4.2. <i>Feasibility of Ideal Charges</i>	172

8.4.3. <i>Backward Induction</i>	173
8.5. OPTIMAL PRICING SYSTEM.....	183
CHAPTER 9: CONCLUDING REMARKS	187
9.1. INTRODUCTION.....	187
9.2. CONCLUSIONS.....	188
9.3. RECOMMENDATIONS.....	193
REFERENCES.....	195
APPENDIX A	201
APPENDIX B	202
APPENDIX C	207

LIST OF TABLES

Table 2.1. Alternative Road Financing Methods	23
Table 3.1. Design Guidelines for Flexible Pavements (MTO, 1990)	42
Table 3.2. Input and Output Items in OPAC 2000 (He et al., 1995).....	43
Table 3.3. OPAC 2000 Parameters	46
Table 3.4. Hot Mix Course Thickness for Different Traffic Situations	53
Table 3.5. Modulus of Elasticity of Different Subgrade Types in Ontario.....	53
Table 3.6. Unit Costs of Pavement Construction	54
Table 4.1. Granular Base Thickness	71
Table 4.2. Vehicle Classification for ESAL Estimation	73
Table 4.3. Average ESALs for different Vehicle Groups	74
Table 4.4. Lane Distribution Factor (LDF).....	74
Table 4.5. Pavement Marginal Costs for different Subgrade Types,	82
Table 4.6. Classifications of Roads.....	83
Table 4.7. Marginal Costs for different Road Classes	84
Table 5.1. Vehicle Classifications	89
Table 5.2. Load Classifications.....	90
Table 5.3. Cost Allocation Matrix, Road Class 1	98
Table 5.4. Cost Allocation Matrix, Road Class 2	99
Table 5.5. Cost Allocation Matrix, Road Class 3	100
Table 5.6. Cost Allocation Matrix, Road Class 4	101
Table 5.7. Cost Allocation Matrix, Road Class 5	102
Table 5.8. Cost Allocation Matrix, Road Class 6	103
Table 5.9. Cost Allocation Matrix, Road Class 7	104
Table 5.10. Cost Allocation Matrix, Road Class 8	105
Table 5.11. Cost Allocation Matrix, Road Class 9	106
Table 5.12. Cost Characteristics of Different Roads	107
Table 5.13. Pavement User Charges for Road Class 1, \$/km	112
Table 5.14. Pavement User Charges for Road Class 2, \$/km	113
Table 5.15. Pavement User Charges for Road Class 3, \$/km	113
Table 5.16. Pavement User Charges for Road Class 4, \$/km	114
Table 5.17. Pavement User for Charges for Road Class 5, \$/km.....	114
Table 5.18. Pavement User Charges for Road Class 6, \$/km	115
Table 5.19. Pavement User for Charges for Road Class 7, \$/km.....	115
Table 5.20. Pavement User for Charges for Road Class 8, \$/km.....	116
Table 5.21. Pavement User for Charges for Road Class 9, \$/km.....	116
Table 6.1. Comparison of the Regression Models for Bridge Cost Estimation	134
Table 7.1. Bridge Cost Matrix, Road Class 1	148
Table 7.2. Bridge Cost Matrix, Road Class 2	148

Table 7.3. Bridge Cost Matrix, Road Class 3	149
Table 7.4. Bridge Cost Matrix, Road Class 4	149
Table 7.5. Bridge Cost Matrix, Road Class 5	150
Table 7.6. Bridge Cost Matrix, Road Class 6	150
Table 7.7. Bridge Cost Matrix, Road Class 7	151
Table 7.8. Bridge Cost Matrix, Road Class 8	151
Table 7.9. Bridge Cost Matrix, Road Class 9	152
Table 7.10. User Charges (\$/km) for Bridges, Road Class 1	155
Table 7.11. User Charges (\$/km) for Bridges, Road Class 2	155
Table 7.12. User Charges (\$/km) for Bridges, Road Class 3	155
Table 7.13. User Charges (\$/km) for Bridges, Road Class 4	156
Table 7.14. User Charges (\$/km) for Bridges, Road Class 5	156
Table 7.15. User Charges (\$/km) for Bridges, Road Class 6	156
Table 7.16. User Charges (\$/km) for Bridges, Road Class 7	157
Table 7.17. User Charges (\$/km) for Bridges, Road Class 8	157
Table 7.18. User Charges (\$/km) for Bridges, Road Class 9	157
Table 7.19. Average User Charges (\$/km) for Bridges, Northern Ontario.....	158
Table 7.20. Average User Charges (\$/km) for Bridges, Southern Ontario.....	158
Table 8.1. Road Life-Cycle Costs for Different Vehicle Scenarios, Billion \$	163
Table 8.2. Road User Charges (\$/km), Road Class 1	167
Table 8.3. Road User Charges (\$/km), Road Class 2	167
Table 8.4. Road User Charges (\$/km), Road Class 3	167
Table 8.5. Road User Charges (\$/km), Road Class 4	168
Table 8.6. Road User Charges (\$/km), Road Class 5	168
Table 8.7. Road User Charges (\$/km), Road Class 6	168
Table 8.8. Road User Charges (\$/km), Road Class 7	169
Table 8.9. Road User Charges (\$/km), Road Class 8	169
Table 8.10. Road User Charges (\$/km), Road Class 9	169
Table 8.11. The Maximum Effect of Optimal Pricing.....	176
Table 8.12. Optimal Payloads for Different Vehicles	182
Table A.1. Nominal Values for Vehicle, Tire, and Pavement Variables	201

LIST OF FIGURES

Figure 1.1. Total Road Building Costs in Canada	2
Figure 2.1. Cost Structure of a Firm Characterized by Scale Economies	14
Figure 2.2. RCI vs Age Histories for Alternative Pavement Strategies	25
Figure 2.3. Factors Influencing Flexible Pavement Fatigue Damage	29
Figure 2.4. Overall Framework of Research Methodology	31
Figure 2.5. Framework of Pavement Cost Analysis Module	32
Figure 2.6. Framework of Bridge Cost Analysis Module	34
Figure 2.7. Framework of Charging Structure Module	35
Figure 3.1. Typical Flexible Pavement Structure	38
Figure 3.2. Stress and Strain under the Pavement Layers	39
Figure 3.3. Pavement Design Procedure	41
Figure 3.4. Load Equivalency Factors from Weights and Dimension Study	47
Figure 3.5. Pavement Cost Structure	49
Figure 3.6. Inputs and Outputs of the Pavement Cost Analysis Module	50
Figure 3.7. Procedures for Pavement Life-Cycle Cost Analysis	51
Figure 3.8. Life Cycle-Costs for a Low Volume Road on a Weak Subgrade	56
Figure 3.9. Life Cycle-Costs for a Low Volume Road on a Strong Subgrade	56
Figure 3.10. Life Cycle-Costs for a High Volume Road on a Weak Subgrade	57
Figure 3.11. Life Cycle-Costs for a High Volume Road on a Strong Subgrade	57
Figure 3.12. Initial Construction Costs vs Initial Pavement Life	59
Figure 3.13. Costs vs Initial Life for a Low Volume Road on Weak Subgrade	60
Figure 3.14. Costs vs Initial Life for a Low Volume Road on Strong Subgrade	60
Figure 3.15. Costs vs Initial Life for a High Volume Road on Weak Subgrade	61
Figure 3.16. Costs vs Initial Life for a Low Volume Road on Strong Subgrade	61
Figure 3.17. The Cost Effects of Environment and Traffic on Pavement Costs	62
Figure 3.18. Life Cycle-Costs vs Initial Pavement Life	63
Figure 3.19. Life Cycle-Costs vs Total ESALs	64
Figure 3.20. Environment and Traffic Costs vs ESALs, Northern Ontario	65
Figure 3.21. Environment and Traffic Costs vs ESALs, Southern Ontario	65
Figure 4.1. General Steps for System-Wide Pavement Cost Analysis	69
Figure 4.2. Pavement Costs in Northern Ontario vs ESALs, $M_s = 73$ MPa	75
Figure 4.3. Pavement Costs in Southern Ontario vs ESALs, $M_s = 73$ MPa	75
Figure 4.4. Pavement Costs in Northern Ontario vs ESALs, $M_s = 42$ MPa	76
Figure 4.5. Pavement Costs in Southern Ontario vs ESALs, $M_s = 42$ MPa	76
Figure 4.6. Pavement Costs in Northern Ontario vs ESALs, $M_s = 35$ MPa	77
Figure 4.7. Pavement Costs in Southern Ontario vs ESALs, $M_s = 35$ MPa	77
Figure 4.8. Pavement Costs in Northern Ontario vs ESALs, $M_s = 28$ MPa	78
Figure 4.9. Pavement Costs in Southern Ontario vs ESALs, $M_s = 28$ MPa	78
Figure 4.10. Pavement Costs in Southern Ontario vs ESALs, $M_s = 24$ MPa	79

Figure 4.11. Pavement Costs in Southern Ontario vs ESALs, $M_s=24$ MPa.....	79
Figure 4.12. Pavement Marginal Costs vs ESALs, Northern Ontario.....	81
Figure 4.13. Pavement Marginal Costs vs ESALs, Southern Ontario.....	81
Figure 5.1. Matrix of Variables in Pavement Cost Allocator Submodule.....	92
Figure 5.2. ESALs versus Payloads for Different Truck Types.....	109
Figure 5.3. Marginal Costs versus Truck Types for Different Load Ranges.....	110
Figure 5.4. Summarized Structure of Cost Allocation Framework.....	111
Figure 5.5. Marginal Cost and Road Charge versus Payload, Vehicle Type 2.....	118
Figure 5.6. Marginal Cost and Road Charge versus Payload, Vehicle Type 3.....	118
Figure 5.7. Marginal Cost and Road Charge versus Payload, Vehicle Type 4.....	119
Figure 5.8. Marginal Cost and Road Charge versus Payload, Vehicle Type 5.....	119
Figure 5.9. Marginal Cost and Road Charge versus Payload, Vehicle Type 6.....	120
Figure 5.10. Marginal Cost and Road Charge versus Payload, Vehicle Type 7.....	120
Figure 5.11. Marginal Cost and Road Charge versus Payload, Vehicle Type 8.....	121
Figure 6.1. Single Slab-On-Stringer Bridge and Its Components.....	125
Figure 6.2. Ontario Bridge Design Reference Truck.....	127
Figure 6.3. Bridge Design Procedure.....	130
Figure 6.4. Number of Provincial Highways Bridges By Material Type.....	132
Figure 6.5. Provincial Highways - Number of Bridges By Total Length.....	133
Figure 6.6. Bridge Cost for all Regions of Ontario Except Northwest.....	135
Figure 6.7. Bridge Construction Cost for all Northwestern Ontario.....	135
Figure 6.8. Relative Bridge Costs vs Design Loading.....	137
Figure 6.9. Frequency of Bridge Construction in Different Years.....	141
Figure 6.10. Present Worth Bridge Costs for Different Vehicle Scenarios.....	142
Figure 6.11. Annualized Bridge Construction Costs for Different Loads.....	143
Figure 7.1. Framework of Analysis of Bridge Cost Impacts.....	147
Figure 7.2. Bridge Usage Fees vs Payload.....	159
Figure 8.1. Road Usage Fees vs Payload.....	170
Figure 8.2. Pavement and Bridge Price vs Payload for Different Truck Types.....	171
Figure 8.3. Interaction of the Pricing System and User Behaviour.....	174
Figure 8.4. Average Per Unit Load User Cost vs Payload, Vehicle Class 2.....	178
Figure 8.5. Average Per Unit Load User Cost vs Payload, Vehicle Class 3.....	179
Figure 8.6. Average Per Unit Load User Cost vs Payload, Vehicle Class 4.....	179
Figure 8.7. Average Per Unit Load User Cost vs Payload, Vehicle Class 5.....	180
Figure 8.8. Average Per Unit Load User Cost vs Payload, Vehicle Class 6.....	180
Figure 8.9. Average Per Unit Load User Cost vs Payload, Vehicle Class 7.....	181
Figure 8.10. Average Per Unit Load User Cost vs Payload, Vehicle Class 8.....	181
Figure B.1. Frequency Distribution of Marginal Cost for Road Class 1.....	202
Figure B.2. Frequency Distribution of Marginal Cost for Road Class 2.....	203
Figure B.3. Frequency Distribution of Marginal Cost for Road Class 3.....	203
Figure B.4. Frequency Distribution of Marginal Cost for Road Class 4.....	204
Figure B.5. Frequency Distribution of Marginal Cost for Road Class 5.....	204
Figure B.6. Frequency Distribution of Marginal Cost for Road Class 6.....	205

Figure B.7. Frequency Distribution of Marginal Cost for Road Class 7.....	205
Figure B.8. Frequency Distribution of Marginal Cost for Road Class 8.....	206
Figure B.9. Frequency Distribution of Marginal Cost for Road Class 9.....	206

CHAPTER 1

Introduction

1.1. ROAD COSTS AND REVENUE POLICIES IN CANADA

Road transportation is the dominant means of transport in Canada as well as in most countries of the world. Road infrastructure has significant economic benefits for society, but requires a significant amount of public investment. Canadian road infrastructure carries over 85 percent of total trips and consumes several billion dollars every year. Each year in Canada trucks and passenger cars travel more than 240 billion kilometres and carry more than 36 million tonnes of goods (Nix et al., 1991). In 1993 more than 17 million registered motor vehicles used over one hundred thousand kilometres of paved roads in the nation. Of those vehicles, over 35% were registered in Ontario (Statistics Canada, 1993).

The Transportation Association of Canada (TAC¹) reported that in 1987 municipal, provincial, and federal governments had invested more than \$200 billion on Canada's highway system (RTAC, 1990). Thereafter, spending on national highways has accounted for about \$5 billion to \$7 billion annually (TAC, 1993 and 1997). Almost 98%

¹ The Transportation Association of Canada, formerly RTAC or the Road and Transportation Association of Canada.

of the road costs in Canada are the responsibility of provincial and local governments (TAC, 1997).

Figure 1.1 shows information on the annual costs of road building activities in Canada and predictions up to the year 2000. The figure only represents the costs associated with construction and reconstruction of roads. Total road costs are 55 to 65 percent higher, when the maintenance and administration costs of road infrastructure are included (Haritos, 1973).

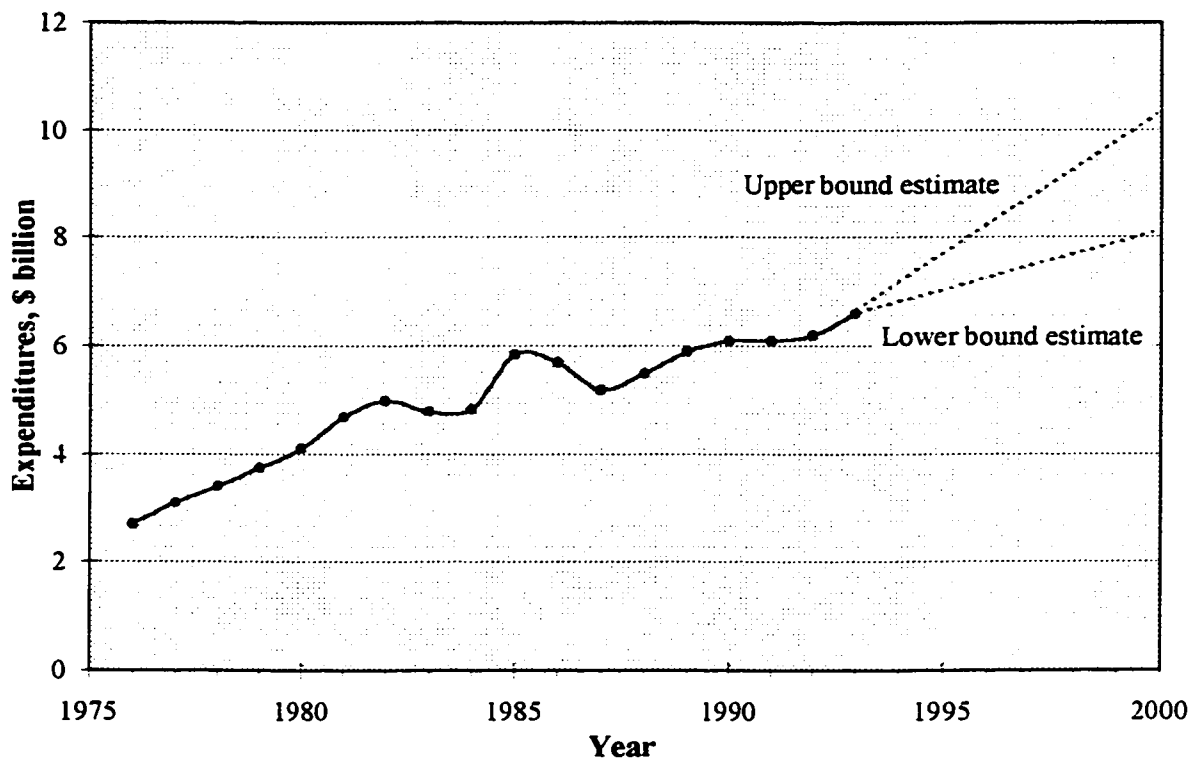

Figure 1.1. Total Road Building Costs in Canada (TAC, 1990 and 1993)

Road transportation demand is continuing to increase, which has resulted in increased congestion, air pollution and higher rates of infrastructure deterioration. Thus, higher maintenance costs will be expected in the future and this raises concern about how to finance those costs.

The conventional view about road financing in Canada is that roads are public goods and consequently funding from general tax revenue is justified (Nix and Jones, 1994). In most cases there are no trust funds or dedicated revenues explicitly linked to road expenditures in Canada (TAC, 1997). Under the conventional view, investment decisions for road projects are primarily made based on engineering criteria (e.g., volume/capacity ratio for capacity and pavement condition for quality) and sometimes, non-engineering criteria for other reasons such as regional development purposes (Nix and Jones, 1994).

The provincial and local legislatures usually collect all taxes and revenues from different sectors (including revenue from the transportation system) and finance roads and other investments from general revenue (TAC, 1997). Provincial revenues from roads are mainly derived from fuel taxes, vehicle registration fees and driver's licence fees. In Ontario as well as in most of the other Canadian provinces, fuel tax revenues account for more than 70% of total road revenues (Gillen and Oum, 1991).

Over the past several decades the perspective in the transportation field has changed from a conventional view to one which considers transportation services as an output consumed by individual users rather than as public goods consumed by everyone (FHWA², 1982; Lacroix, 1993). This has encouraged governments to seek full road cost recovery by directly charging the road users. Highway 407 in the Toronto region provides an example. Road taxes and user fees, also, provide incentives for efficient utilization of resources and serve as a mechanism for cost recovery (Gillen and Oum, 1991; Litman, 1995). These have raised the fundamental question of how to efficiently allocate the capital and continuing costs of highway infrastructure to different users of the road transportation system (Bunting, 1991).

In Canada, there have been several government inquiries into the subject of highway finance since the late 1950s. An Ontario Select Committee on Toll Roads and Highway Financing (1957) recommended that road users should pay for all road costs and

² Federal Highway Administration.

the provincial highway system should be self-supporting. The Committee also recommended that the fuel tax should be used as the primary mechanism to charge road users for road use (Bryan, 1972).

The last of the major commissions making recommendations on highway finance in Canada was The Royal Commission on National Passenger Transportation (1992). The Commission emphasized continuing reliance on registration and fuel taxes, but with an understanding that these taxes are explicitly for the payment of roads. Therefore, except for externalities (e.g., air pollution) the Commission recommended that the federal government should stop collecting fuel taxes and provincial governments should cease using their fuel taxes on non-road modes. The Commission also suggested that fuel taxes should not be set higher than the marginal costs of road use so as not to discourage road use unnecessarily. Under this strategy, additional cost recovery could be achieved by higher registration fees and other devices such as weight-distance taxes for heavy vehicles (Nix and Jones, 1994). The commission also recommended greater use of toll facilities, especially for new inter-city road projects and congested roads within urban areas. Based on the above suggestions, attention should be paid to issues such as the cost impact of vehicle axle loads for inter-city roads and congestion and air pollution costs for urban roads and streets.

1.2. COST ALLOCATION ANALYSIS IN CANADA

Highway cost allocation studies are concerned with the financing methodologies and the cost responsibilities of different road users and provide decision makers with directions for efficient investment and pricing in order to maximize social welfare (Nix and Jones, 1994). To analyze the road taxation structure effectively, a sound knowledge of the physical and economic properties of road systems is essential.

Road cost allocation studies have been undertaken in many countries around the world (e.g., the United States, 1982, and Australia, 1990). In Canada, the only comprehensive highway cost allocation study dates back over 20 years ago. It was

conducted by Haritos in 1973 and is clearly out of date. Haritos used 1968 road cost data and employed engineering and regression approaches to accomplish the road cost allocation analysis. A two-part price structure including capital costs as fixed costs and maintenance costs as variable costs was employed. Haritos considered costs which could be avoided within the time frame of one year as variable costs and allocated them to different users on the basis of vehicle usage (vehicle-distance). He treated the costs which could not be avoided within a year as fixed costs and argued that these costs should be recovered through annual fees such as vehicle registration and licencing.

Nix et al. (1991) conducted a study on road costs and road user charges in Canada for the Royal Commission on National Passenger Transportation. The study obtained cost implications for different vehicle types such as standard automobiles, three-axle trucks, five and six-axle semitrailers, and eight-axle B-trains both loaded and empty. Capital costs were allocated to various axle-weight groups, and variable costs were allocated on the basis of vehicle usage. This study had many data constraints and required simplifying assumptions that made the findings too general to be applicable for accurate road cost analysis in Canada.

1.3. GENERAL ISSUES IN HIGHWAY COST ALLOCATION ANALYSIS

The set of road user charges is considered to be both an instrument for financing the road costs and an approach for achieving efficient utilization of transportation resources (McRae, 1991). Highway user charges for different user groups are usually based primarily on political considerations in order to meet budget requirements (World Bank, 1991). However, to achieve an efficient pricing system, the cost characteristics of different components of the road transportation system and the consumption of road infrastructure by different groups must be analyzed comprehensively and incorporated into the charging structure.

The cost components of road transportation systems are primarily the initial capital, rehabilitation and maintenance costs of pavements and bridges of the road

network. Road users may also impose external effects (e.g., noise and air pollution) on some parts of society that may not be the direct beneficiaries of the transportation system. The additional user costs to vehicles traveling over damaged pavements and bridges may be significant for road users. Costs incurred by traffic delays may also be significant in congested urban areas and on high volume rural roads, but this is not the focus of this research.

The characteristics of roads vary across the road network. Roads carry different traffic volume and loadings and because of this are designed to different standards, leading to differences in initial construction costs and subsequent rehabilitation and maintenance costs. High volume roads are usually designed with high quality materials and design standards which result in low marginal costs of road use. The fixed costs per vehicle may also be low for high volume roads because of the large traffic volume. Low volume roads are usually designed to a lower standard that leads to relatively larger average and marginal costs per vehicle.

Different operating costs of different vehicle types as well as variations in capital and operating costs of different vehicles and the different objectives of road users result in a wide range of vehicle types used by different road users. Different vehicle types will have different impacts on pavements and bridges due to their configurations, commodities carried and cargo densities. Pavement damage caused by vehicles also varies between pavement structures.

A cost-based charging system must recognize these differences and reflect them in the structure of the user charges (World Bank, 1991). Thus, vehicles should be charged differentially, depending on the damage they cause and their share of road use. Charges should be estimated in accordance with systematic criteria and based on an appropriate cost allocation methodology.

Cost allocation studies must consider the types of investments proposed, the theoretical merits of alternative cost allocation and charging methods, and the practical problems in applying alternative methodologies used to collect calculated charges. The major goal of road pricing is to recover the road expenditures from the road users in such

a way that the road user prices promote the efficient use of the road network and are rational and equitable (World Bank, 1991).

For inter-city road networks, pavement and bridge life-cycle costs have been widely accepted as a basis for the calculation of user charges. They are the most important source of road costs and their physical behaviour (e.g., deterioration due to fatigue) and economic implications can be formulated (Nix et al., 1991).

1.4. PROBLEM DEFINITION AND RESEARCH OBJECTIVES

The problem of appropriate allocation of infrastructure damage costs to highway users must involve the relationships between economic and technical aspects of road infrastructure. Various design, construction and maintenance strategies will have different impacts on road life-cycle costs and can lead to different cost responsibilities and price arrangements between users of the road system. A sound knowledge of the physical behaviour of the road infrastructure as well as the cost implications of vehicle configurations and pavement and bridge attributes is the key for efficient and rational allocation of costs in road transportation systems.

The various charging instruments may have different economic implications in terms of relating the user charges and user costs. For example, there could be entrance fees such as fixed annual vehicle registration fees and/or variable fees such as a fuel tax which users pay as they use the system. Fixed fees may affect the decision of users as to whether they want to use the system at all, while the variable fees may have short term effects on the decision of users to make a particular trip. Different charging systems may incur different administration costs. A sound understanding of these factors is important for designing an efficient and acceptable charging structure for recovering the road construction, maintenance and rehabilitation costs.

The above issues have lead to the primary goal of this research and that is to establish appropriate charges for the users of the road network and to discuss the

principles and methods by which road authorities can ensure the optimal utilization of road transportation systems. The specific objectives of this research are as follows:

1. To provide insights into the factors influencing pavement and bridge damage for the Ontario road network and to convert them to appropriate monetary terms.
2. To calculate marginal costs associated with different road users.
3. To develop a comprehensive road cost allocation model which could consider both the technical and the economic aspects of roads within a unique framework.
4. To calculate cost responsibilities of different road users for their use of Ontario pavements and bridges, including the marginal and total cost responsibilities.
5. To investigate the implications of different charging methods and instruments.
6. To provide guidelines for improving the efficiency and effectiveness of the road charging system in Ontario.

The research reported in this thesis analyzes the factors influencing road costs. The physical and economic behaviour of highway pavement and bridge systems under traffic and climatic forces are described. A comprehensive cost allocation algorithm is described which calculates the cost responsibilities of different road users. In addition, the effects of different charging schemes on road user costs are analyzed in order to arrive at practical solutions for designing an efficient and admissible charging structure for the Ontario inter-city highway network. The focus of road pricing in this study is on pricing the usage of existing road system rather than optimizing long-run investment.

1.5. THESIS ORGANIZATION

This thesis is organized into nine chapters. Chapter 2 describes the theoretical background of the research and reviews the concepts of road economics and pricing as well as the general characteristics of pavements and bridges and their physical behaviour. The chapter also explains the general framework of the procedures used in this research.

Chapter 3 provides the technical background on pavement design procedures and the physical behaviour of pavements. Also, the behaviours of representative pavements

in Ontario are analyzed and the general life-cycle cost characteristics of pavements are illustrated and discussed.

In Chapter 4 pavement analyses are conducted at the network level. The cost characteristics of pavements at different locations in Ontario and with different physical and traffic characteristics are analyzed and their performances are estimated. The marginal road costs associated with different pavement groups in Ontario are also calculated. The roads are categorized into several groups based on their traffic situations for the purpose of the cost allocation analysis.

A new method of cost allocation analysis, based on cooperative game theory, is introduced in Chapter 5. The mathematical framework of the proposed method is described and a cost allocation model is developed. The pavement costs for the Ontario road system are distributed among the road users using the proposed cost allocation method.

Chapter 6 describes bridge design procedures as well as the cost characteristics of bridges in Ontario. The chapter also evaluates the cost characteristics of bridges in Ontario at the network level.

Chapter 7 is concerned with the allocation of bridge costs between the road users in Ontario. The bridge cost allocation methodology and its mathematical framework are described in the chapter. The cost allocation results are presented and discussed.

In Chapter 8 the results of the pavement and bridge cost allocation analyses are merged. The policy implications of different taxation schemes as well as the cost characteristics of the system for different user groups are discussed. The characteristics of an optimal road pricing system in Ontario are also discussed.

Chapter 9 summarizes the results and conclusions of the research as well as the implications for cost allocation analyses. Recommendations are also made for future work which could extend the results of this research.

CHAPTER 2

Background and Research Methodology

2.1. INTRODUCTION

Calculations of the cost responsibilities of different road users requires a thorough understanding of relationships between road deterioration, vehicle configuration and road design standards. While the road pricing problem is an economic problem by nature, the engineering background concerning the physical characteristics of roads must be acquired in order to establish a meaningful link between road user cost impacts and road prices. This requires a sound knowledge of pricing and economic theories as well as a good understanding of the physical behaviour of road structures.

The goal of this chapter is to provide a comprehensive review of the procedures and information available for road cost allocation analysis and for estimating the impact of vehicles on road life-cycle costs. Literature and procedures dealing with road cost allocation analysis can be divided into two subgroups: *i*) economic and financial aspects of the road infrastructure, and *ii*) physical behaviour of pavements and bridges.

The chapter begins with a review of the economic theory of pricing and existing cost allocation procedures. The physical behaviour of roads under traffic and environmental loadings is then reviewed. The conceptual framework of this research is also briefly described at the end of the chapter.

2.2. ROAD PRICING THEORY

2.2.1. Goals of Cost Allocation Analysis

Highway cost allocation provides bases for evaluating road tax structures by ascertaining whether the relative shares of revenues paid by each user group are appropriate, whether they should be adjusted, and whether charging instruments should be modified (Trucking Research Institute, 1990). To meet such goals, cost allocation studies must consider two fundamental issues in the provision of road services including: *i*) efficiency, and *ii*) equity. The concept of efficiency is concerned with the best possible utilization of the system in short-run and the optimal investment in long-run. The concept of equity is concerned with the distribution of costs and benefits among different groups of road users and society. Road user fees have a direct influence on short-run efficiency and also affect the actual pattern of investment in long-run (FHWA, 1982). There is no specific definition to assert that some user charges are equitable or inequitable and equity is inherently a matter of political choice. The popular idea of equity is to treat equals equally and to reduce income disparities.

The full picture of road costs and finance requires an integrated analytical framework that takes both the technical and economic aspects of road infrastructure into account. Such a system could result in effective policy recommendations for rational road pricing and could regulate the demand for highway services. It could also offer insights into determining the optimal and most efficient level of investment for building and maintaining sufficient road services. Also, in order to properly charge different road users it is important to consider the types of investments, the physical behaviour of road structures, the impact of different vehicles on road damage and costs, the theoretical

problems of alternative cost allocation algorithms, and the practical characteristics of different charging instruments.

Since pricing can affect the decision of road users, it is important to understand the relationship between road prices and the behaviour of road users in regard to demand for using the road system. The following subsections describe the economic aspects of road cost and cost allocation analysis.

2.2.2. Cost Elements in Road Networks

It is important to understand the economic characteristics of pavements and bridges since they have important roles in the development of an efficient pricing framework. Road costs may be classified into escapable and inescapable costs. The escapable costs are variable costs that depend on the number of vehicles using the system and can be partly or completely avoided in the absence of vehicle journeys. Generally, escapable costs are a function of the physical characteristics of vehicles and roads and the number of kilometres traveled. Inescapable costs are invariable whether particular vehicle journeys take place or not. For example, a minimum cost may be required to build a pavement section regardless of the level of traffic volume on that road. Road damage occurs over long periods of time while principal expenditures occur at only a few points in time. Road costs, therefore, may be viewed with respect to different time frames (i.e., short-run versus long-run). In the short-run, once the investments are undertaken, increased levels of road use may not significantly increase the financial requirements for the provision of road services. In the long-run all costs may be considered to be variable.

Roads are common facilities and different types of users with different cost implications use them. Some parts of the road costs may be attributable to particular users or a class of users. These are known as separable costs. For example, stronger bridges may be required to withstand heavy axle loads of commercial trucks compared to automobile loads. Therefore, the extra costs of building stronger bridges may be only attributable to heavy trucks. There are also common costs, those associated with services

and activities attributable to many road users. For example, road shoulders, parking areas and commercial facilities are designed and built to be used by all vehicle groups. Those costs are attributable to all groups of vehicles.

Both traffic and environmental forces contribute to pavement deterioration. The distortion of the pavement surface due to environmental factors is a significant portion of the deterioration of flexible pavements in Canada (Hutchinson, 1991). The portion of costs due to vehicle loadings can be attributed to individual vehicles, provided that the effect of each vehicle on pavement deterioration can be calculated. The pavement costs due to environmentally related factors may not be attributable to particular vehicles and are viewed as common costs. In addition, there are external costs (externalities) that may not be incurred directly by the users of road infrastructure but by other society members.

Different types of road costs must be identified prior to cost allocation analysis and each type of costs should be allocated to different vehicles according to the special characteristics of each cost item and user group.

2.2.3. Review of Cost Curves

Jansson (1984) characterized inter-city roads simply as 'plants' for the production of transport by motor cars and trucks. In this regard, highways produce two types of output: *i*) traffic volume, and *ii*) equivalent single axle loadings (ESAL). Equivalent single axle load (ESAL) is defined as the number of passes of a standard axle load required to create the same amount of damage as one pass of a candidate axle load. Traffic volume is facilitated by road width and number of road lanes, and standard axle loadings require durability in terms of pavement strength (a factor of pavement thickness). Therefore, ESALs may be considered the major output of the inter-city road transportation system.

The inter-city highway finance problem may be resolved into one of supply and demand. Prices may influence the demand for use of road services and consequently affect the level of output. Mohring and Harwitz (1962) showed that the plausibility of

road cost and finance analysis largely depends on the characteristics of the cost functions associated with roads. It has also been identified that significant scale economies associated with the durability output of roads exist in the case of inter-city highways (Small et al. 1989).

Figure 2.1 illustrates the typical cost structure of firms including pavement systems. In the case of inter-city highways, the long-run average cost per unit of output (ESAL) declines as the level of output increases. This is due to the scale economies in the provision of highway pavements. It follows from the scale economies that the long-run average cost curve would have a negative slope and the long-run marginal cost curve would lie below the average cost curve (Frankena, 1979). The demand curve is shown by a negatively sloped line in the figure and represents the basic rule of economics: products that are cheaper or more convenient would be used more (CBO, 1992).

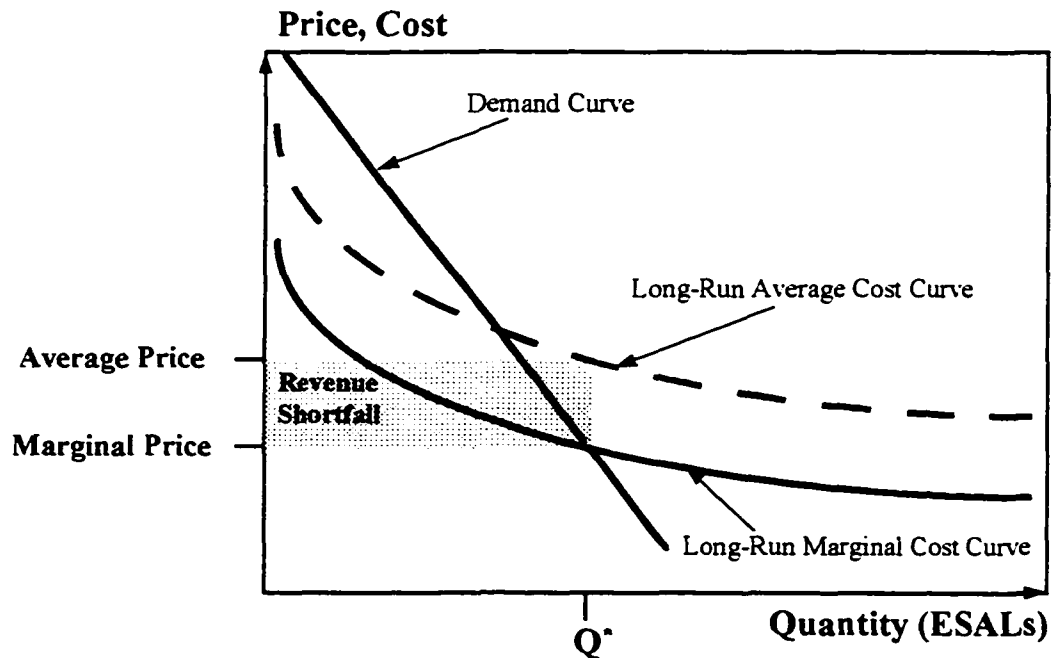

Figure 2.1. Cost Structure of a Firm Characterized by Scale Economies

The fundamental road pricing principle which ensures that a facility is being used efficiently is that trips should be taken by all road users who are willing to pay the long-run marginal cost of their trips (Haritos, 1973). Therefore, the most efficient quantity of output (Q^*) is established where the demand and marginal cost curves intersect. However, the marginal cost of a service is less than its long run average cost where positive scale economies exist. In this case marginal cost pricing would result in a revenue shortfall equal to the shaded area in Figure 2.1 which must be recovered through other methods such as subsidy or secondary charges on top of marginal cost-based price. Since demand is a decreasing function, full cost recovery through user fees (e.g., charging the long-run average cost) would result in an output less than Q^* . This lowers economic well-being as a result of the under-production of services (CBO, 1992).

2.2.4. Review of Pricing Methods

In general prices may be arranged based on different fundamental concepts including: *i*) average cost pricing, *ii*) marginal cost pricing, *iii*) social marginal cost pricing, *iv*) value of service pricing, *v*) benefits-based pricing, and *vi*) Ramsey quasi-optimal pricing. Each method has advantages and disadvantages depending on the characteristics of the method and the nature of the costs in different systems.

In average cost pricing, prices are set at the intersection of the demand curve and average cost curve. In the case of positive scale economies, average costs are greater than marginal costs and setting prices at the average cost may decrease the level of utilization of the road system. It would be rational to let more users utilize the system as long as they are willing to pay the marginal cost of their trips. Therefore, average cost pricing would recover total costs but will not yield a full and efficient utilization of the road infrastructure.

The idea behind marginal cost pricing is to collect only the marginal costs of road use, those that could be saved if the user did not use the system, the so-called escapable costs. As noted previously, marginal cost pricing may not recover the full cost of the road system, when positive scale economies exist. This method may overcome the problem of

inefficiency in production and consumption associated with average cost pricing. For example, the average cost of using a particular road section might be \$1.00 per trip, while the damage cost of an extra movement (marginal cost) might be \$0.50. In this case, the marginal cost pricing would not recover the total costs, because the marginal cost of usage is less than the average cost. On the other hand, it may make sense to let a vehicle use the system if the marginal cost of the trip can be collected. If the user is not willing to pay at least the marginal costs of the trip, there may not be any justification in providing the user with the service.

Although marginal cost pricing theoretically results in efficient use of the system, there are other difficulties, besides a revenue shortfall, in using marginal costs. First, marginal cost depends on the analysis time horizon. Highway pavement costs are lumpy and the selection of the appropriate time horizon is critical for cost analysis. Moreover, marginal cost pricing is difficult to apply to roads due to indivisibility of some of the fixed cost elements. Also, in practice, it may be difficult and costly to record the marginal cost of road use associated with each trip. Finally, changes in road design standards may significantly influence the magnitude of marginal costs associated with different users. Some road users may argue that they would have had lower marginal costs if much stronger pavements were built (Small, 1990).

Social marginal cost pricing is similar to marginal cost pricing. The difference is that social marginal cost pricing not only considers the road costs associated with a road user, but also recognizes the costs which the user imposes on others (external costs). For example, a road user would be responsible for road wear costs as well as the costs of increased congestion and associated delay imposed on others. The logic behind social marginal cost pricing is that users will consider the costs imposed on others when making decisions regarding the mode, quantity and timing of the services they will purchase (Gillen and Oum, 1991).

The value of service pricing seeks to collect the price each user is willing to pay. In this method everyone can use the system at the price they wish to pay. The argument here is that the reason some users would value a service less than others is that their

services may be less profitable. This may be because their service is not as valuable to the public, limiting their profitability. Therefore, the value of service pricing may set the prices in the favour of non-profitable users and may contradict efficiency issues. Under the value of service pricing economic efficiency may be reduced (Gillen and Oum, 1991).

In the benefits-based method prices are set according to the benefits received by different users. Benefits-based pricing has the same disadvantages as the value of service pricing. The value of service and benefits-based methods may be assumed to demonstrate equitable cost allocation in the sense that the users are charged based on what they are willing to pay or afford (Trucking Research Institute, 1990).

Ramsey pricing allocates the charges based on assigning the full marginal cost responsibility of each user plus a second best pricing. The major goal of Ramsey pricing is to minimize the loss of economic efficiency caused by the deviation of price from marginal cost when full cost recovery is sought. Ramsey pricing uses the inverse-elasticity rule to set prices up over marginal costs while ensuring that the quantity of service supplied will deviate as little as possible from the optimal quantity under marginal cost pricing (Gillen and Oum, 1991). Price elasticity reflects the rate of change in demand for each percentage change in price. The inverse-elasticity rule states that the ratio of the excess of the selling price over marginal cost must be proportional to the inverse of the price elasticity of demand. This may imply minimum reduction in output as a result of charging more than the marginal cost of trips. Ramsey pricing provides the optimal utilization of the system and minimizes the total loss of welfare.

The inverse-elasticity rule affects overall user charges in the following way. The rule allocates a lower portion of fixed costs per ESAL to trucks which are more sensitive to changes in price. For example, if the cost per ESAL associated with two road users are equal but the road users have different price elasticities, Ramsey pricing would allocate a higher price per ESAL to the user that is more price elastic. Price elasticities may differ between commodity groups and vehicle weights and may change over time according to changes in commodity prices (Oum et al., 1990).

Ramsey pricing frequently appears in theoretical discussions of public pricing and is favoured by economists. The Ramsey pricing method is complex and requires information on the demand elasticity function (Gillen and Oum, 1991). Another problem with Ramsey pricing is that it is difficult to know the unconstrained optimal set of outputs (i.e., under marginal cost pricing) for road system currently operating under budget constraint (Jansson, 1984). To employ Ramsey pricing for road cost allocation analysis, it is important to know the level of demand for different charges per ESAL and the sensitivity of different road users to changes in prices.

Although the above arguments may imply that there are several conflicting issues involved in the cost allocation analysis, those restrictions should not discourage planners and economists from studies of the economics of transportation systems. There must be an optimal system in which the prices are based on sound rationales. Such a system could result in effective policy recommendations for rational road pricing and could regulate the demand for highway services. The following paragraphs describe the existing approaches developed to rationalize the cost allocation analysis for full cost recovery.

Each of the above methods individually does not consider efficiency, equity or total cost recovery issues at the same time. Different cost allocation approaches may be developed to overcome the pitfalls of each of the above concepts and to establish an optimal charging system (Wheeler, 1996). The most common approaches used in practice are the Incremental and Federal Methods which have frequently been acknowledged by existing literature (Oregon Department of Transportation, 1993; Trucking Research Institute, 1990).

The Incremental Method is based on the concept of escapable costs. A minimum system is initially defined to provide the service for basic vehicles (i.e., automobiles). The costs of the basic system are allocated to all vehicles (i.e., cars and trucks) in proportion to their usage of the system, as if they all had the same physical characteristics (Fwa and Sinha, 1985). The additional costs of accommodating heavier vehicles are considered to be avoidable costs, if those vehicles were excluded from the system, and should be recovered only from those vehicles. In the Incremental Method, vehicles are

grouped into several classes according to their physical properties and damage implications. For example, there may be a base vehicle group (usually passenger cars) followed by small trucks, medium size trucks and heavy trucks. The costs of the road system are re-estimated as if the system was originally designed for each individual vehicle class. The assumption is that there is an incremental cost associated with each successive vehicle class. Each successive incremental class shares in the costs required to accommodate the smaller vehicle classes. In other words, smaller vehicles do not share in the incremental costs required for providing road services for heavier vehicles. Only the heaviest vehicle class pays all the costs of the last increment.

A primary criticism of the Incremental Method is that it provides heavier vehicles with a differential benefit from the economies of scale in pavement costs as each unit of pavement thickness increment adds proportionately much more strength than the previous unit. Also, there are concerns about how to rank different vehicles especially when the road facilities may be considered as consumable resources (Trucking Research Institute, 1990). For example, in the case of pavements, the damage implications of different trucks may not be measured by size or gross vehicle weight and it may depend on the spacing and configuration of vehicle axles. As noted before, the damage imposed by different vehicles may be measured in terms of their equivalent single axle loads (ESAL) which can also be viewed as a measure of output of the road system. Therefore, it may be assumed that pavements are consumed rather than being used by road users.

The Federal Method is a modified version of the Incremental Method. The method was developed during the 1979 to 1982 period in the United States by the Federal Highway Cost Allocation Study (FHCAS). The Federal Method distinguishes consumable road components from those that are not consumed by road use (FHWA, 1982). For example, the method recognizes pavements as consumable components of the road system as they deteriorate over time as a result of both traffic and environmental forces. The method uses weight-distance pricing for consumable elements that deteriorate under increasing use by heavy vehicles. The method allocates the pavement costs to each vehicle in proportion to their ESALs for each unit distance

traveled. The method also recognizes common costs such as capital costs of bridges and right-of-way costs of providing roads. These cannot be linked with road use.

The Federal Method uses the Incremental Method for allocating these costs (Trucking Research Institute, 1990). These modifications make the Federal Method more equitable than the Incremental Method. However, considering that each cost item should be allocated differently based on judgment about the best method for that item, each analyst may have a different method for allocating some costs. Some road items could also be allocated differently whether they were aggregated or disaggregated into larger or smaller expenditure categories. Also, additional costs could result from poorly designed or poorly maintained roads, suggesting that such non-optimal costs should be viewed as common costs and not separable costs. Therefore, another argument would be whether users as a whole should pay on a different basis for the optimally designed portions of roads than for the non-optimal life-cycle costs of roads (Trucking Research Institute, 1990).

Besides the above cost allocation frameworks, the application of cooperative game theory to cost allocation analysis has been suggested by different authors (Mirman et al., 1985; Young, 1985a and 1985b). The game theory approach defines road users as a group with mutual benefits from sharing the road system. A road user, or group of users, may enter the system to avoid the additional costs of using a separate system. This entry may have some benefits for the other users of the system, since they share the system costs with the new participants (Hurley, 1989).

Game theory provides mathematical models for the relationships between the interests of different user groups and finds feasible solutions for the cost allocation problem (Littlechild, 1970; Littlechild and Thompson 1977; Mirman et al., 1985; Rothengatter, 1991). The theory has several advantages over the above methods and seems to be promising in handling the complexities of road cost allocation analysis. The details of this approach and its application to the road cost allocation analysis are discussed in Chapter 5.

2.3. CHARGING INSTRUMENTS

The road charges may be categorized into four major groups related to: *i*) vehicle usage, *ii*) vehicle ownership, *iii*) vehicle acquisition, and *iv*) beneficiaries of road access. The first three groups of road charges are directly levied on road users and the fourth group may not necessarily be levied on road users and is usually used for municipal streets and rural access roads (Gillen and Oum, 1991). Road user charges are collected using four main types of charging instruments: *i*) fuel taxes, *ii*) import duties, excise and sales taxes, *iii*) vehicle license fees, and *iv*) tolls. The most widely applied user charges are fuel taxes (World Bank, 1991). The taxation of road users is affected by: *i*) structure of the tax, *ii*) nature of the charging instruments, *iii*) accuracy of monitoring vehicle operations and enforcement, *iv*) procedures for assessing user cost responsibilities, *v*) combination of tax collection methods, and *vi*) penalty system. A tax system would be ineffective if the characteristics of the tax system encourage using legal loopholes to avoid payments (World Bank, 1991).

An important difficulty associated with the choice of charging instruments has been the inability to relate the user charges to the time and place where the usage takes place (Gillen and Oum, 1991). Emerging technology provides a promising outlook for implementation of new instruments to monitor precisely the movements and loadings of vehicles. Road authorities may use a mixture of charging instruments to collect road user charges in order to achieve higher levels of equity and efficiency. However, as a general rule, the greater the complexity of the charging system, the higher the administrative expenditures would be to collect the charges.

Since user charges are supposed to promote efficient use of the road network, the charging instruments should provide complementary incentives (to enforcement and penalties) for efficient use of the road system. In general user charges are efficient when no person can be made better off without making someone else worse off (Pareto-optimal condition) if an alternative charging method was used (Gillen and Oum, 1991; Heggie, 1991).

The Federal Highway Cost Allocation Study (FHWA, 1982) recommended that for highway user charges to be economically efficient, it is desirable that:

1. Each vehicle pay the marginal cost of road use on each trip occasion.
2. The benefits from usage accrue directly to the user whether or not they are eventually passed on to others.
3. The user accurately perceives both the benefits and prices of each occasion of use including the benefits and prices of other alternatives.

The study suggested that a number of charging instruments must be selected and combined so that there would be some means of charges related to the variable costs of the road system (a function of road use) and some means of charges related to the fixed or capital costs of the road system. In the case of trucks, taxes must properly account for differences in truck axle weights and other characteristics affecting road damage costs.

Table 2.1 explains the advantages and disadvantages of different charging instruments. As can be observed from the table, different charging instruments may satisfy particular goals of the taxation system. Fuel taxes, vehicle license fees and weight-distance charges are the most widely used charging instruments for collecting highway costs. Fuel consumption varies with vehicle usage, but it may not be related to the costs of road use associated with each vehicle journey. This is because there is not any direct relationship between fuel consumption and road damage. Fuel tax may encourage the use of trucks with a lower number of axles, since an increase in truck axles implies higher fuel consumption as a result of higher drag and rolling resistance. The most attractive characteristic associated with fuel taxes is that they are easy to implement and administer (World Bank, 1991).

Tolls or road access fees can be used to acquire sufficient revenue for the improvement of particular road segments. They are easy to administer, but may be costly to collect and may impose high compliance costs on taxpayers when collected manually (World Bank, 1991). Land-value increment taxes can be used for acquiring the expenditure needs of building low-volume land access roads. This system may only work

when there are rules which require developers to provide such roads and the government is willing and able to enforce the regulations (World Bank, 1991). Attempts should be made to ensure that the charging beneficiaries do not result in double-counting the taxes.

Table 2.1. Alternative Road Financing Methods

Method	Advantages	Disadvantages
Fuel Taxes	<ul style="list-style-type: none"> • easy to collect • price-inelastic (so that it can generate lots of money in short term) • efficient (more use, more tax) 	<ul style="list-style-type: none"> • unrelated to congestion • encourage heavy trucks with fewer axles • unrelated to road damage
Congestion Tolls	<ul style="list-style-type: none"> • improves efficiency as it makes users pay close to social marginal costs (efficient use of given capacity and efficient capital investment in long-run) 	<ul style="list-style-type: none"> • not easy to calculate social optimal tolls by road section and time • takes time to collect • inequitable distribution of prices
Construction of Toll Roads	<ul style="list-style-type: none"> • efficient in utilizing a given road capacity in short-run (if it is well managed and regulated) • easy to administer 	<ul style="list-style-type: none"> • impracticable for low volume roads • may create extra congestion unless proper technology is used
Annual License Fees	<ul style="list-style-type: none"> • easy to collect • can generate large revenue 	<ul style="list-style-type: none"> • not related to road usage (demand may change after it is collected) • difficult to administer
Charging Beneficiaries	<ul style="list-style-type: none"> • justifies the projects economically 	<ul style="list-style-type: none"> • does not guarantee efficient use of roads
Weight-Distance Charges	<ul style="list-style-type: none"> • provides high levels of fairness • reflects more accurate cost responsibility of users 	<ul style="list-style-type: none"> • expensive • administration complexity if applied in disaggregate levels

Administration feasibility is yet another concern. A charging system may be so complex that the costs of collection and enforcement outweigh the benefits. A single fee structure may satisfy one or two of the objectives, mentioned before, but may violate the other criteria (i.e., efficiency and equity). Therefore, economic efficiency and administration costs must be balanced and charging limitations must be considered in the road cost allocation studies.

2.4. PHYSICAL BEHAVIOUR OF PAVEMENTS AND BRIDGES

Cost allocation analysis requires an understanding of the mechanism of truck-road and truck-bridge interactions as well as non-traffic factors that cause road deterioration (e.g., aging and environmental factors). Models of pavement and bridge deterioration are the basis of the cost analyses, since pavement and bridge costs are the major sources of expenditures in road networks and they can be quantified. The focus of this section is on the concepts of current pavement and bridge deterioration models.

2.4.1. Pavements

The principal pavement type used in Canada is a flexible pavement consisting of granular base and subbase courses and a surface course of asphaltic concrete. Almost 90 percent of all pavements in Canada are of this type (TAC, 1997). Pavement serviceability is defined as the ability to serve the road users at an acceptable level of comfort and is directly related to the roughness of the pavement surface (TAC, 1997). The serviceability of pavements decreases over time as a result of increasing surface distress (e.g., fatigue cracking and rutting) as well as reduction in surface friction. The principal mechanism contributing to the surface distortion of flexible pavements is the repeated subgrade deflection resulting in permanent deformation of the subgrade surface. This eventually results in permanent deformation of pavement surface and a decrease in riding quality of the pavements. Traffic loadings as well as climatic effects (e.g., freeze-thaw cycles and subgrade moisture) are the major factors contributing to the deformation of the subgrade (TAC, 1997; Rilett et al., 1989).

In Canada, the riding quality of a pavement is usually characterized by either the Riding Comfort Index (RCI) which is a subjective measure rated on a scale from 0 to 10, or International Roughness Index (IRI). New pavements typically have an initial RCI of 8.5 which decreases over time. Pavements are normally considered to have deteriorated to an unacceptable condition when the RCI has declined to a minimum level (Haas, 1994; Hutchinson, 1991). The minimum RCI is usually set at 5.5 for freeways and as low as 3.5 for collector roads. The magnitude of heavy loads and the amount of traffic have a direct

effect on the rate of pavement deterioration. Figure 2.2 illustrates hypothetical RCI versus age histories that might result from a range of pavement strategies.

It has been determined that increasing loads on vehicle axles exponentially increase pavement damage. Most of the pavement deterioration models are based on a concept of the relative pavement damage of different axle loads. The standard axle load is usually defined as 80 kN on a single axle supported by dual tires. The equivalent single-axle load rating of any other axle load is called an ESAL (equivalent single axle load) or load equivalency factor (LEF) and is defined as the number of passes of the standard axle load required to create the same amount of damage as one pass of a candidate axle load.

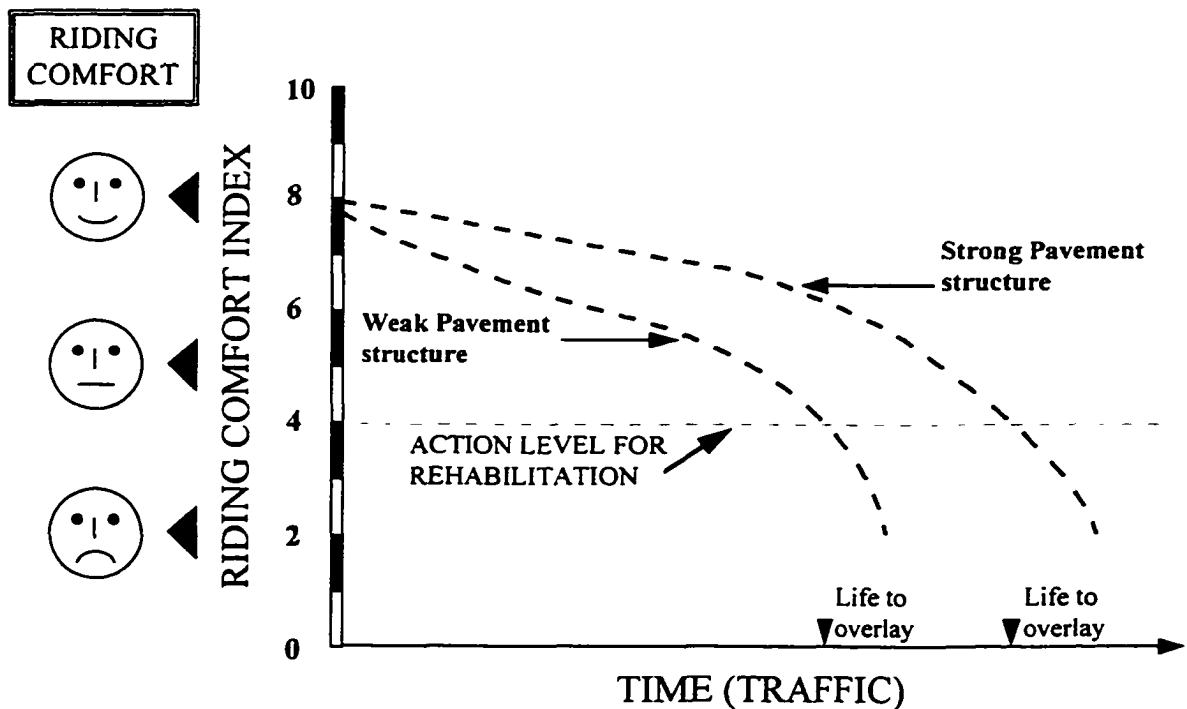

Figure 2.2. RCI vs Age Histories for Alternative Pavement Strategies (Kher, 1975)

AASHO³ Road Test (AASHTO³, 1993) completed a substantial amount of research on load equivalency factors. AASHO (now AASHTO) studied the relationship between pavement life and thickness in an accelerated empirical pavement study conducted between 1958 to 1960 (AASHTO, 1993). The relationships can be represented by the following equation:

$$LEF = \left[\frac{L(x)}{L(s)} \right]^{\approx 4} \quad [2.1]$$

where, $L(x)$ is the candidate axle load and $L(s)$ is the standard axle load. The exponent in Equation [2.1] is an approximation and is actually found to be about 3.8 for flexible pavements and varies with structural design, serviceability and loading factors. Equation [2.1], with its exponent of approximately 4, is usually referred to as the "Fourth-Power Law". Vehicle suspension types and number of tires also affect the rate of damage imposed by each vehicle.

Pavement performance refers to relationships between pavement serviceability and pavement age throughout its lifetime. Understanding pavement performance and its relationship to vehicle and environmental factors is essential for the purpose of pavement optimal design and cost analysis. The optimum design and rehabilitation planning of pavements has significant benefits and savings for the public and road agencies. Many models have been developed to predict pavement deterioration under traffic loadings and climatic effects. Among the most useful models are those of AASHTO (AASHTO, 1993) and Ontario (i.e., OPAC⁴) (MTO, 1997). The results of AASHO studies have been the basis for other studies conducted thus far. AASHO specified a non-linear equation relating a precisely defined measure of pavement quality to the n number of applications of the standard axle.

³ American Association of State Highway and Transportation Officials, formerly know as AASHO (American Association of State Highway Officials).

⁴ The Ontario Pavement Analysis of Costs (OPAC).

The forecasting equation hypothesized by AASHO is:

$$P = P_0 - (P_0 - P_\infty)(n / \rho)^\beta \quad [2.2]$$

where, P is the overall pavement quality, P_0 and P_∞ represent the initial and terminal pavement qualities, respectively. The variable ρ is the number of standard axle passes that will cause the pavement to wear out and β is a coefficient that can be estimated by ordinary least squares. The estimation procedures for ρ and β are described in the AASHTO Guide for Design of Pavement Structures (AASHTO, 1993; Hudson et al., 1991).

The most recent AASHTO Guide for Design of Pavement Structures (AASHTO, 1993) has developed procedures which separate performance loss due to traffic and environment. The concept is reflected in Equation 2.3 and implies that pavement deterioration due to traffic and environmental factors is separable.

$$\Delta P = P_{traffic} + P_{swell/frost\ heave} \quad [2.3]$$

The AASHTO model estimates the traffic-associated part of pavement deterioration based on Equation [2.2]. The effects of environmental factors (i.e., $P_{swell/frost\ heave}$) on pavement damage can be represented by the age and location of a pavement since different climatic situations may affect the serviceability of pavements differently. Pavements located in cold regions are subject to freeze-thaw effects, causing deterioration at each cycle. The longer a pavement section is subject to deteriorating climatic factors, the more its serviceability declines. The details of the above factors are not provided in this research (since the AASHTO model is not used in the analyses accomplished in this research).

The OPAC model was developed based on the results of the AASHO Road Test in which the accelerated traffic loading was the dominant factor and on the longer-term

Brampton Road Test in Ontario. It was designed to ascertain the effects of both traffic and environmental factors on pavement deterioration in Ontario. The OPAC model has similar properties to the AASHTO model and the details of the structure of the OPAC pavement performance equations are explained in Chapter 3. The primary advantage of the OPAC model is its ability to separate pavement degradation due to environmental and traffic-associated factors and that it is calibrated for Ontario pavements. Modifications to the OPAC model (OPAC 2000) have recently been advanced by MTO (He et al., 1995). In the modified version of the OPAC pavement performance model the pavement performance equations have been calibrated separately for the pavements in the northern and southern parts of Ontario. The OPAC 2000 model is selected for use in this research for the analysis of flexible pavements..

2.4.2. Factors Affecting Pavement Performance

Gillespie et al. (1994) performed several analyses under the NCHRP⁵ to explain the relationships between vehicle and pavement properties and pavement damage. Figure 2.3 summarizes the effects of different factors on pavement fatigue damage as noted by Gillespie et al. (1994). The figure shows the range of damage when individual vehicle, tire, and pavement factors vary around typical values. The typical ranges of values for each of the variables are shown in Appendix A.

It can be concluded from the figure that the most important factors affecting pavement damage are axle loads, gross weight, suspension type, tire type, surface temperature and wearing course thickness. However, it can also be observed from the figure that fatigue damage to pavements is mostly determined by maximum axle load, pavement thickness and surface temperature. It may also be concluded that other vehicle properties such as truck speed and tire pressure have a smaller, but still significant, influence on pavement fatigue. Pavement properties significantly influence the rate of pavement fatigue damage. The most important pavement factors are surface temperature

⁵ National Cooperative Highway Research Program (NCHRP) is part of the Transportation Research Board (TRB) of the United States National Research Council.

and pavement thickness. Surface temperature creates concern in hot regions such as southern parts of the US. In conclusion, the NCHRP report states that:

... From an efficiency of transport perspective, the large multi-vehicle combinations with low-axle loads produce less road wear per ton-mile of transport. ... Multiple axles at lighter loads reduce fatigue in both rigid and flexible pavements. Although gross weight most directly determines flexible pavement rutting, the larger combinations are, nevertheless, the least damaging on a ton-mile basis because of the higher proportion of cargo to tare weight with these combinations.

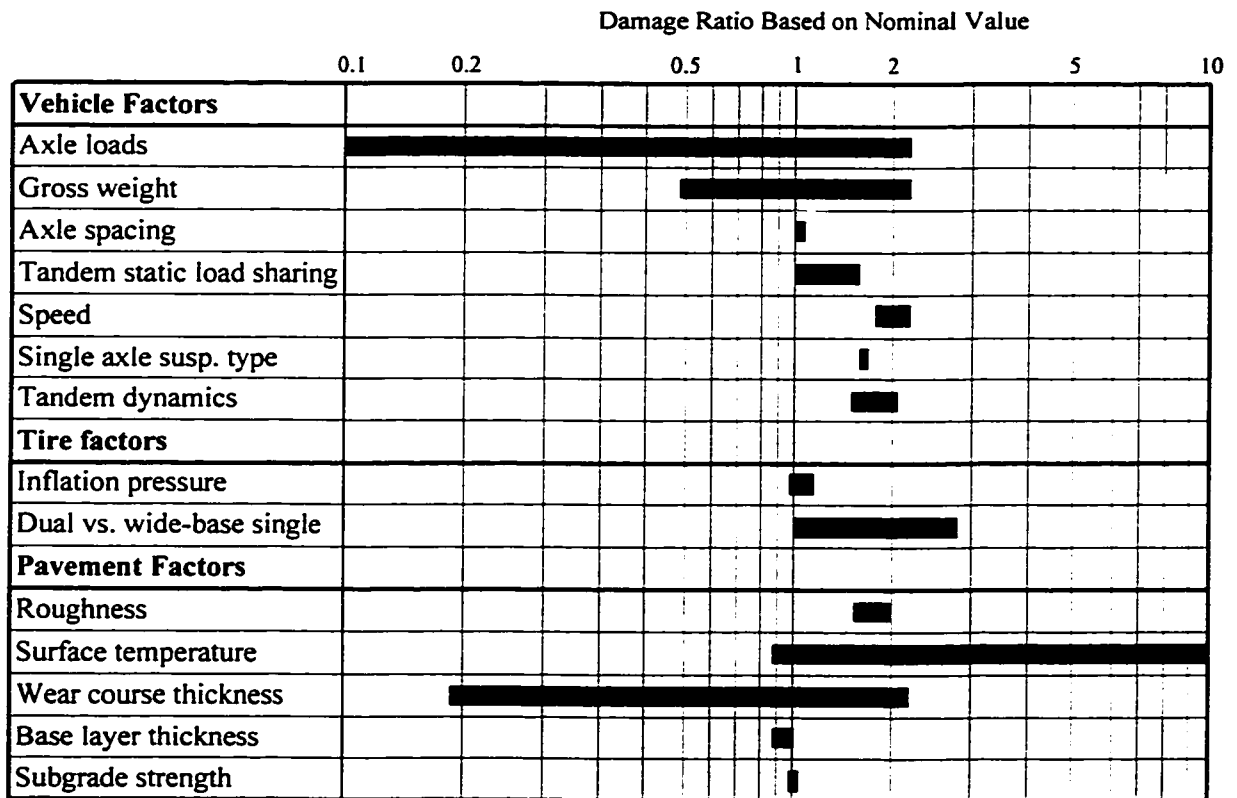

Figure 2.3. Factors Influencing Flexible Pavement Fatigue Damage
(Gillespie et al., 1994)

2.4.3. Bridges

The nature of bridge costs is somewhat different from pavement costs. The useful life of bridges is much greater than pavements and the magnitude of capital investments in bridges is much higher compared with their maintenance costs. Failure in bridges may be extremely expensive and have severe safety consequences. Unfortunately, there has not been as much attention paid to this part of the road costs as to pavement costs. Comprehensive models of bridge deterioration which could quantify the impact of vehicle loadings and environmental forces could not be found and it was realized that the relationship between bridge damage and costs are not clear. Documenting bridge costs may be a difficult task since improvement of bridge condition requires several activities ranging from repairs of individual bridge elements to replacement of the whole bridge.

The forces imposed on bridges by trucks are a function of the forces transmitted through the tires, the spacings between truck axles, the location of trucks on bridge span, the number of trucks on a span, and the lengths of bridge spans or bridge components. The bending moment induced in bridges (or bridge components) of different span lengths by trucks, or axle sub-sets of trucks, is one of the most important force effects considered in bridge design (Moses, 1992). In the case of long span bridges, gross vehicle weight plays the most significant role in bridge damage and dead loads tend to dominate. Axle loads, axle spacing, and suspension design, however, are important parameters relative to loading on short span bridges and many critical bridge components (TAC, 1988).

2.5. RESEARCH APPROACH AND METHODOLOGY

2.5.1. General Framework

The overall framework of this research is outlined in Figure 2.4. The figure indicates the three major modules that have been used and these are:

1. Pavement cost module.
2. Bridge cost module.
3. Charging structure module.

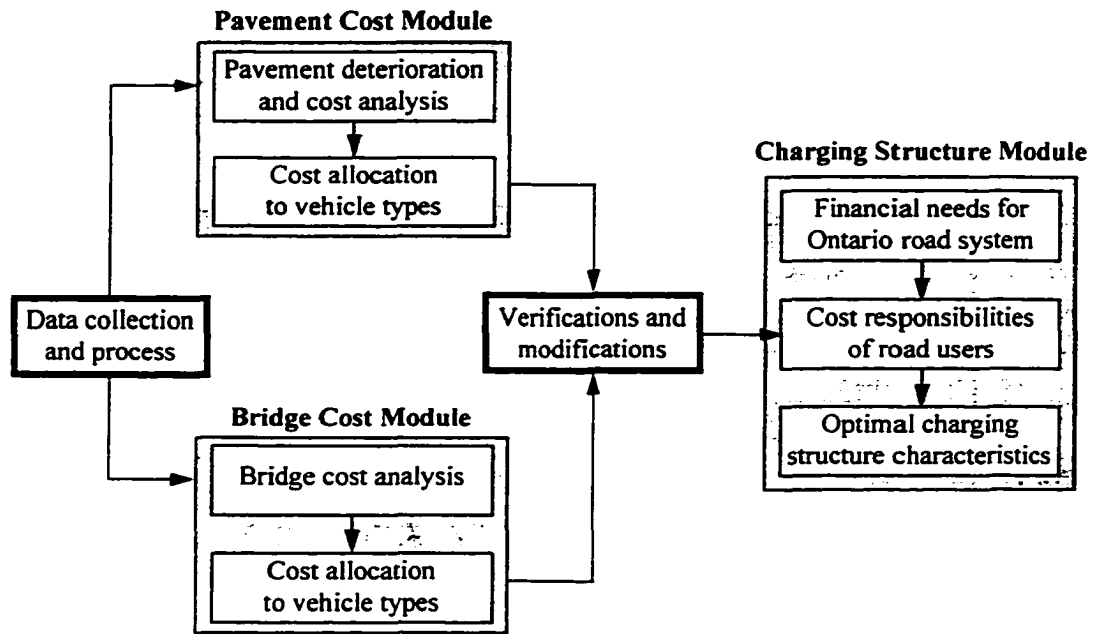

Figure 2.4. Overall Framework of Research Methodology

The modules are linked together as illustrated in the figure and their contents are described as follows. The first step is to collect and assemble the travel and network data for the Ontario highway system. The sources of these data are explained in the next chapters of this thesis for each corresponding analysis. In general, most of the data is obtained from the Ministry of Transportation of Ontario.

The objectives of the pavement and bridge cost modules are to estimate the cost characteristics of Ontario pavements and bridges, respectively. The pavement and bridge cost modules each contain two submodules, one for analyzing average and marginal costs associated with different users, and the second for the allocation of costs to different classes of vehicles. The charging structure module contains three major submodules. First, the financial needs of the Ontario road system including pavement, bridge and administration costs should be analyzed and combined. The theoretical total user cost responsibilities are then carried out and used for analyzing the road charging structure.

2.5.2. Pavement Cost Analysis Submodule

Figure 2.5 shows the required procedures and their inter-relationships for the pavement cost analysis module. The first step in this task was to collect information about the characteristics of pavements and vehicles in Ontario. These data were used to calculate ESALs created by different vehicles and the overall thickness of different pavement sections (in terms of granular base equivalent thickness).

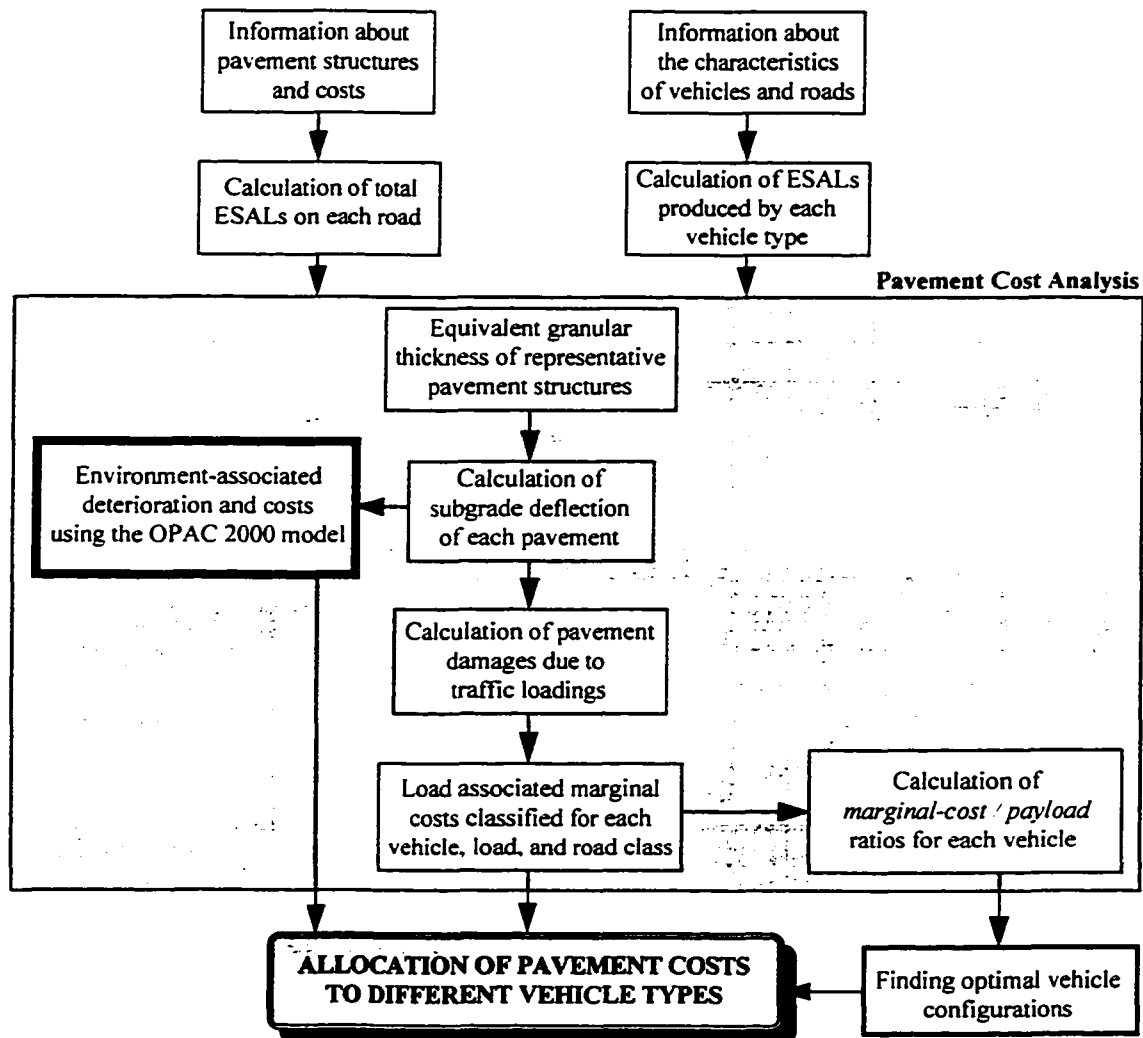

Figure 2.5. Framework of Pavement Cost Analysis Module

Each pavement section was analyzed to calculate its deterioration due to traffic and environmental factors using the OPAC 2000 equations which are described in detail in Chapter 3. The deterioration of pavements was then converted to monetary values which were used to estimate the marginal costs of road use. The *marginal-cost/payload* ratios associated with different vehicles were found in order to compare the relative efficiencies of different vehicles operating with different load levels on different road types in Ontario.

The cost allocation analysis was accomplished through a mathematical programming framework in which the restrictions are established based on the concepts of game theory. The concepts of game theory and the procedures used for cost allocation analysis in this research are described in Chapter 5.

2.5.3. Bridge Cost Analysis

The variety of bridge spans and bridge structural systems as well as varying levels of traffic make it difficult to achieve general mathematical models for bridge performance. According to the MTO's Structural Office, bridge expenditures constitute less than 14 percent of the total road expenditures. Existing studies indicate that the deterioration of bridges is mainly caused by environmental effects and bridge maintenance costs constitute a very low percentage (less than 1%) of total bridge life-cycle costs (Xanthakos, 1996). Therefore, the focus of bridge cost analysis in this research is on the capital costs of bridges. Figure 2.6 illustrates the methods used for bridge cost analyses and allocation.

To accomplish bridge cost analysis, bridge data along with traffic and vehicle data were used to find the cost characteristics of Ontario bridges. The initial bridge costs were estimated for different design loads (bridge design vehicles) in order to find the cost responsibilities of different vehicles for the capital costs of bridges. The maintenance costs of bridges were added to the capital costs of bridges and these data were used to

accomplish a comprehensive cost allocation analysis for the total life-cycle costs of Ontario bridges. The details of the cost allocation approach are explained in Chapter 7.

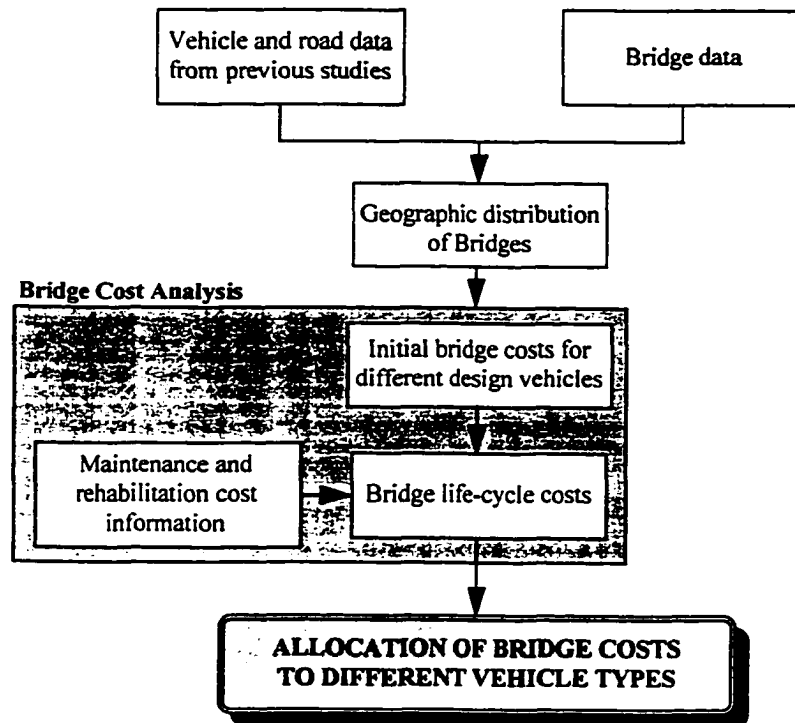

Figure 2.6. Framework of Bridge Cost Analysis Module

2.5.4. Charging Structure Module

Road costs must be recovered by road revenues derived by various pricing mechanisms. For example, it may be preferable to recover the maintenance costs associated with a particular part of a road by only charging the users of that road segment, but it may not be practical or economically justifiable. The limitations in different charging instruments must be understood in order to design a sound charging system. The goal of this part of the research is to find the characteristics of an appropriate charging system for the Ontario inter-city road network.

Figure 2.7 shows the major activities involved in the analysis. The first step was to merge the results of pavement and bridge cost allocation analyses and other road costs such as administration costs in order to arrive at total cost responsibilities of different vehicle types. The estimated cost responsibilities found through the game-theoretical cost allocation procedure are assumed to be the ideal set of charges which would be preferred to be collected from different road users. In practice, however, it may not be feasible to set the charges exactly equal to theoretical, ideal charges, due to practical and technological difficulties.

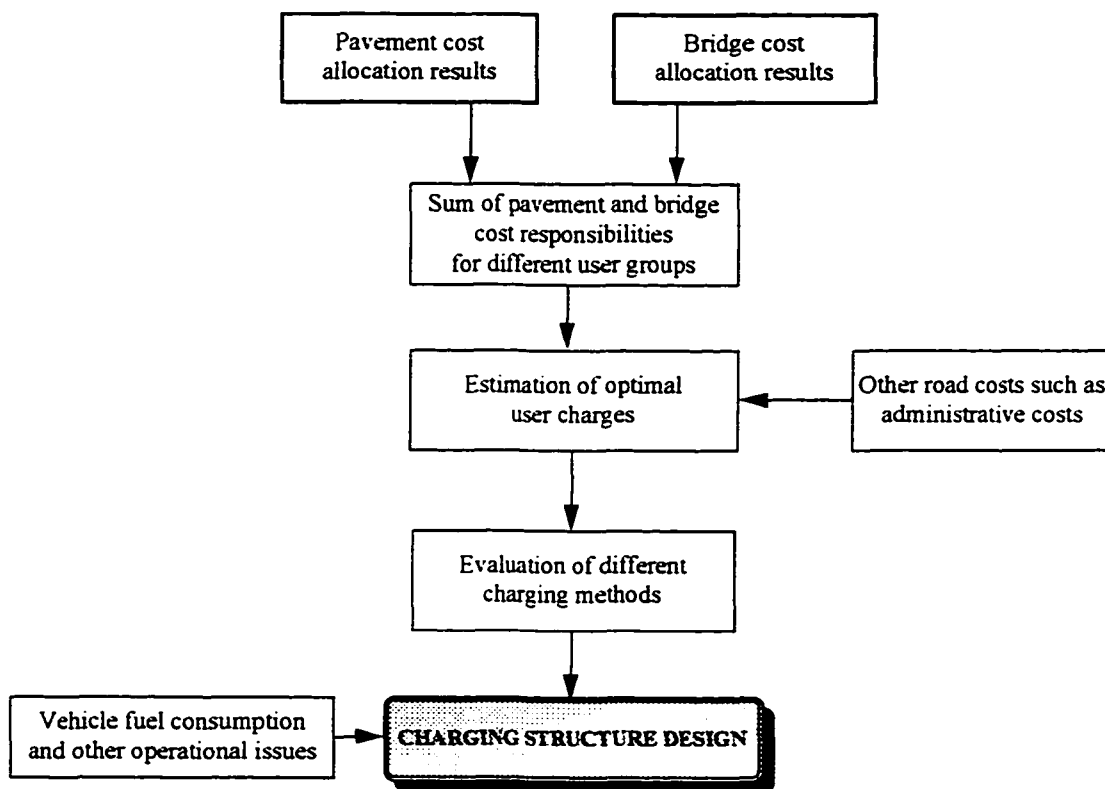

Figure 2.7. Framework of Charging Structure Module

The user charges under different pricing schemes are calculated and verified with a set of theoretical charges estimated in this research. In considering the advantages and disadvantages of different charging methodologies, some guidelines have been suggested to improve the taxation system for the Ontario road network.

Finally, it must be noted that various factors involving the economic and physical characteristics of road networks and complex interactions between vehicles and road components (e.g., pavements and bridges) make it difficult to calculate accurately the cost responsibility of each user. Even if the optimal cost responsibility of different users can be calculated, it may not be feasible to precisely collect them because of administration limitations. However, it is worthwhile to compute such charges since the results can lead to optimal arrangements of road user charges in practice and/or improving the existing charging structure.

CHAPTER 3

Analysis of Flexible Pavements in Ontario

3.1. INTRODUCTION

Previous chapters have mentioned that pavements deteriorate as a result of environmental impacts and repeated loadings imposed by vehicle axle loads. To maintain pavement serviceability at an acceptable level, pavements are periodically resurfaced, reconstructed or maintained, all requiring expenditures. To carry out a reliable cost analysis, the deterioration process of pavements must be well understood. This chapter provides an overview of pavement design procedures and the factors affecting the durability of flexible pavements. Also, the general characteristics of pavement structures in Ontario are analyzed.

3.2. PAVEMENT STRUCTURES

3.2.1. Pavement Layers and Materials

Flexible pavements consist of three major segments including: *i*) roadbed, *ii*) subgrade, and *iii*) pavement structure. Roadbed is where the pavement is placed and is the initial support for the pavement structure and shoulders. Subgrade is the top surface

of the roadbed which consists of prepared and compacted soil to support the pavement. The subgrade acts as the foundation for the pavement structure and shoulders. Pavement structure is the top layer of the system which distributes vehicle loads to the subgrade (TAC, 1997). Flexible pavements usually consist of a bituminous surface over a granular base and subbase (base or subbase may be omitted) as shown in Figure 3.1.

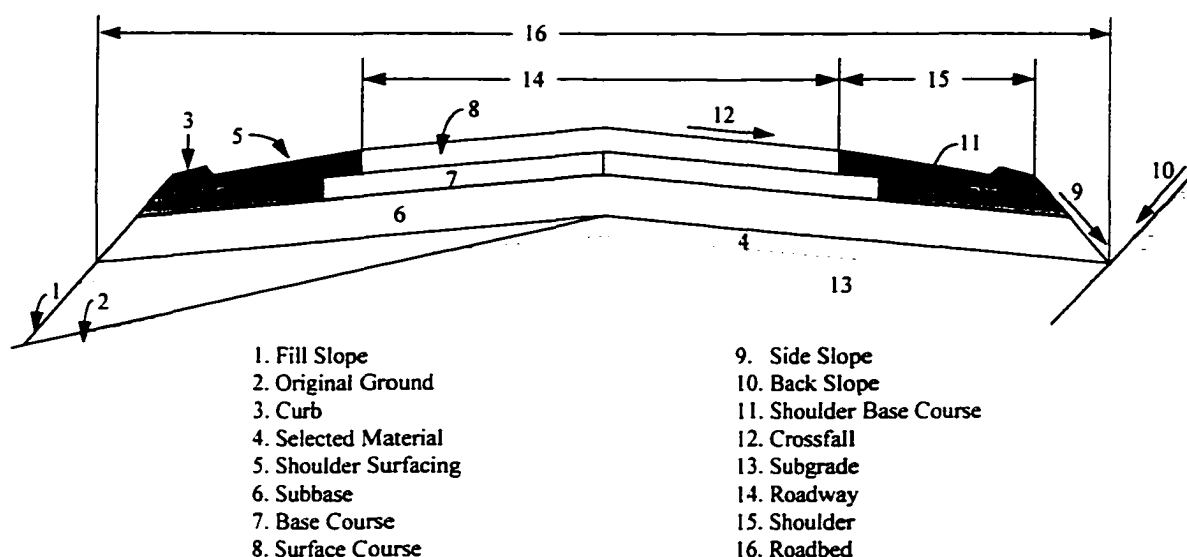

Figure 3.1. Typical Flexible Pavement Structure (Modified from TAC, 1997)

Typically, the surface layer of flexible pavements in major highways consists of asphalt concrete which is a mixture of aggregate with crude oil products plus additives or modifiers processed at high temperature. For some roads with low traffic, aggregate may be mixed with liquid asphalt in plants. This mixture is called “cold mix” since low or no heat is required in the process. The base course is usually a layer of processed aggregate constructed upon the subbase. Its purpose is to transfer loads imposed by vehicles from the surface layer to underlying layers of the pavement and to transmit water away from the surface. The subbase usually consists of poorer quality and less costly granular material and its purpose is to transmit the loads from the layers above to the subgrade. The subbase helps to reduce the stresses transmitted to the subgrade and also protects the subgrade from moisture and seasonal frost effects by providing the subgrade with a relatively thick granular cover (TAC, 1997).

3.2.2. Mechanics of Flexible Pavement Behaviour

As noted in the previous chapter, the riding comfort of roads decreases over time as a result of surface distress (e.g., fatigue, cracking and rutting); as well, there can be a reduction in surface friction. The distortion of the pavement surface comes from deformation of the subgrade within the pavement structure and/or shear deformation. The mechanism of pavement deterioration and the effect of traffic and environmental loads on pavement distress are explained in the following.

Vehicle axle loads deflect the pavement downward and create short-term stresses and strains. Pavement fatigue damage is created by cyclic longitudinal strain at the bottom of the surface course where maximum tensile strains occur (Jung, 1974). Also, in the case of viscoelastic materials (such as hot mix asphalt), repeated loads can result in rutting. Figure 3.2 illustrates the stress and strain under axle loads for a typical pavement structure.

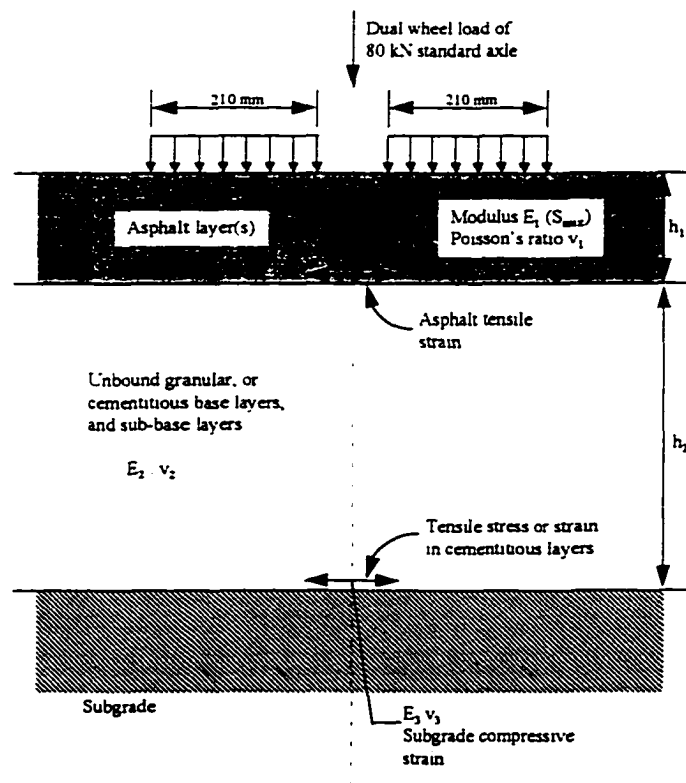

Figure 3.2. Stress and Strain under the Pavement Layers (Modified from TAC, 1997)

Climatic factors such as moisture and freeze-thaw cycles may also have a significant influence on pavement distortion because they affect the strength of subgrade materials. Low temperature cracking contributes to pavement deterioration as well, because it allows water to enter the pavement structure and reduces the strength of the pavement. However, at high temperature asphalt is less likely to develop cracks, but it may be subject to rutting.

3.2.3. Initial Pavement Design Process

The initial design of pavements has a significant effect on pavement performance. The construction of strong pavement structures requires thicker pavement layers with higher quality materials that are initially more costly than the construction of weaker structures. As a general rule, thicker and stiffer pavement layers will result in better pavement performance because the traffic loads will be transmitted and distributed to subgrade over a broader area. In other words, under the same traffic, location and material conditions, a thinner pavement structure will deteriorate faster than a thicker pavement structure (Jung et al., 1975). As a result, the stronger pavements may provide the road users with adequate riding quality and comfort for a longer time than a weaker pavement before the pavements should be rehabilitated. This may favourably affect vehicle operating costs as well as road user time which may be wasted during the pavement rehabilitation and maintenance processes.

Figure 3.3 shows the framework of pavement design procedures. Predetermined criteria and assumptions (e.g., pavement expected life and acceptable serviceability level) that are used for designing pavements play a significant role in the design of initial pavement structures. Another important factor is the local costs of materials and labour wages that should be considered in the economic evaluation of different structural alternatives.

In Ontario, the Ministry of Transportation has developed a list of standard flexible pavement designs that has been derived from analyses of in-service performance of historical pavement test sections and data from laboratory tests. The guidelines for the

structural specifications of flexible pavements are tabulated for different subgrade types and traffic conditions in Table 3.1 (MTO, 1990). As shown by the table, less than 130 mm of hot mix is usually placed on top of a 150 mm granular base. The thickness of subbase depends on the traffic condition and the subgrade characteristic of the road section. In the case of higher volumes of traffic, or scarcity of granular materials, treated materials may be used as substitute for the granular materials in the base and subbase.

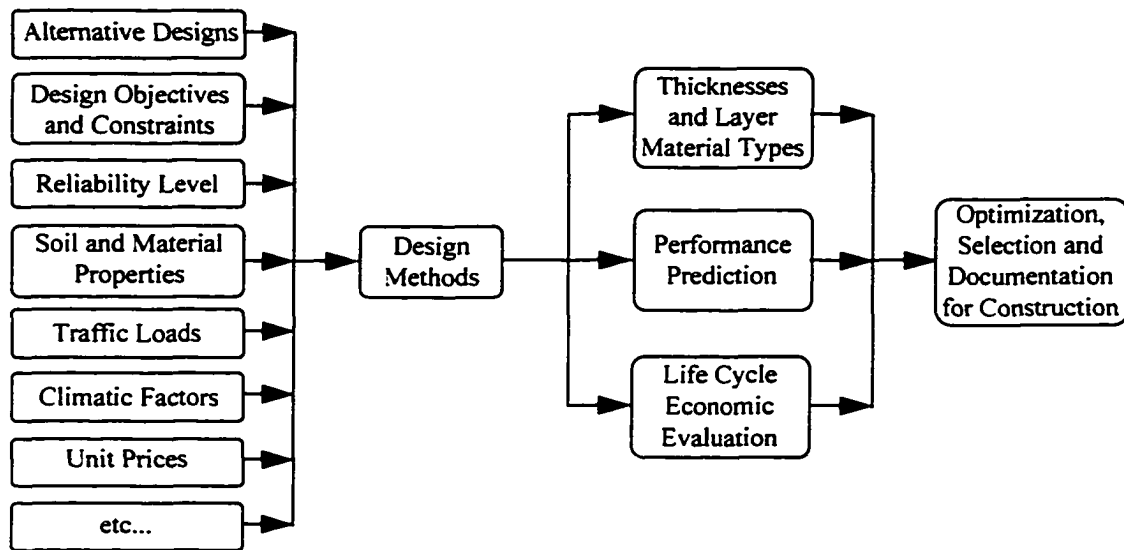

Figure 3.3. Pavement Design Procedure (TAC, 1997)

Different construction, maintenance and rehabilitation options have different costs and different pavement performance implications. Therefore, a compromise between the higher initial costs of strong pavements with the higher maintenance costs of weaker pavements is the basis of pavement design and cost evaluation. This task requires the ability to predict the riding quality of pavements at different points of pavement life. The following section describes the details of the OPAC 2000 pavement performance model which is the basis of the prediction of pavement condition and cost analysis in this research.

Table 3.1. Design Guidelines for Flexible Pavements (MTO, 1990)

AADT ¹	Pavement Structure	Subgrade Material					
		Gravel and Sand	Sand and Silts			Lacustrine Clays	Varved & Leda Clays
			5-75 µm <40%	5-75 µm 40-55%	5-75 µm >55%		
> 4000	HM ²	130	130	130	130	130	130
	B ³	150-250	150	150	150	150	150
	SB ⁴	---	300-450	450-600	600-800	450	450-1100
	GBE ⁵	410-510	610-710	710-810	810-945	710	710-1145
3000 to 4000	HM	120-130	120-130	120-130	120-130	120-130	120-130
	B	150-250	150	150	150	150	150
	SB	---	300-450	450-600	600-800	450	450-1100
	GBE	390-510	590-710	690-810	790-945	690-710	690-1145
2000 to 3000	HM	90	90	90	90	90	90
	B	150	150	150	150	150	150
	SB	---	300	450	600	450	800
	GBE	330	530	630	730	630	865
1000 to 2000	HM	50	50	50	50	50	50
	B	150	150	150	150	150	150
	SB	---	250	300	450	300	300-600
	GBE	250	415	450	550	450	450-650
200 to 1000	HM	50	50	50	50	50	50
	B	150	150	150	150	150	150
	SB	---	150	250	300	250	250-450
	GBE	250	350	415	450	415	415-550

¹Average Annual Daily Traffic, ²Hot Mix Asphalt, ³Base, ⁴Subbase, ⁵Granular Base Equivalent Thickness.

3.3. THE OPAC 2000 PAVEMENT PERFORMANCE MODEL

3.3.1. The Structure of the OPAC 2000 Model

The principles of pavement performance models were briefly described in Chapter 2. It was also mentioned that pavement serviceability is usually quantified by using subjective measures such as Riding Comfort Index (RCI) or objective measures such as International Roughness Index (IRI). Measurements of riding comfort are usually correlated with pavement roughness which can be measured by various mechanical or electrical devices.

In MTO, pavement serviceability is measured with the Pavement Condition Index (PCI), which incorporates both riding quality and surface distress in the following relationship:

$$PCI = 100\sqrt{0.1 \times RCR} \frac{205 - DMI}{205} C + S \quad [3.1]$$

where, *RCR* represents the riding quality measured by the Portable Universal Roughness Device, *DMI* is the Distress Manifestation Index (weighted sum of 15 types of distresses), and *C* and *S* are constants. *PCI* is rated on a scale of 0 to 100 and is analogous to *RCI* but in a different scale ($PCI \approx 10 \times RCI$) (MTO, 1990).

Table 3.2 illustrates the required input information as well as the outputs of the OPAC 2000 model. Required information includes subgrade and pavement characteristics, traffic data, road location and performance limits. Many results may be achieved through the OPAC 2000 system including pavement structural design and performance curves which are of fundamental interests.

Table 3.2 Input and Output Items in OPAC 2000 (He et al., 1995)

Required Inputs	Outputs
<ul style="list-style-type: none"> • Pavement materials • Subgrade data • Traffic data • Performance limits • Cost data 	<ul style="list-style-type: none"> • Structural design alternatives • Life-cycle costs • Expected life • Economic and strategy rankings • Performance and cost graphs

The general form of the OPAC model is described by Equation [3.2]:

$$P = P_0 - P_T - P_E \quad [3.2]$$

where, *P* is the overall pavement performance index, *P₀* is the initial performance index, and *P_T* and *P_E* denote the performance loss due to traffic and environmental factors, respectively.

To evaluate the performance of different pavement structures, a proposed pavement structure must be converted to an equivalent thickness, H_e , of granular material on the subgrade. Layer equivalencies for each material type may be used to transform a pavement structure into the granular base equivalent (GBE) thickness. This is based on the assumption that the equivalent granular thickness induces the same subgrade deflection as the actual pavement structure under a standard wheel load. Representative layer equivalencies for Ontario are suggested as (Jung et al., 1975):

$$\text{Surface : Base : Subbase} = \sqrt[3]{M_1 / M_2} : \sqrt[3]{M_2 / M_2} : \sqrt[3]{M_3 / M_2} = 2 : 1 : \frac{2}{3} \quad [3.3]$$

The deflection of the subgrade surface, W_s , likely to occur under the standard wheel load is then estimated using the formula shown by Equations [3.4] and [3.5].

$$W_s = \frac{T}{2 M_s z \sqrt{1 + (a / z)^2}} \quad [3.4]$$

$$z = 0.9 H_e \sqrt[3]{(M_2 / M_3)} \quad [3.5]$$

where,

T = the load on the dual tires,

M_s = the subgrade modulus of elasticity,

a = the radius of the circular area of contact of the dual tires,

H_e = equivalent granular thickness of the pavement,

M_2 = the modulus of elasticity of the asphalt layer,

M_2 = the modulus of elasticity of the granular base layer, and

M_3 = the modulus of elasticity of the granular subbase layer.

The numbers of ESALs are then used along with the subgrade deflection to estimate the loss in RCI over time due to traffic using the following equation (Jung et al., 1975):

$$\Delta RCI_T = 2.4455\Psi + 8.8050\Psi^3 \quad [3.6]$$

where,

$$\Psi = 3.7283 \times 10^{-6} \times W_s^6 \times N,$$

N = accumulated ESALs, and

W_s = subgrade deflection, mm.

The loss in RCI due to the environment, P_E , is estimated from the subgrade deflection and the number of years in service as shown by Equation [3.7]:

$$P_E = (P_0 - P_\infty) \times (1 - e^{-\alpha Y}) \quad [3.7]$$

where, α is constant and Y , P_0 and P_∞ represent pavement age, initial and final pavement conditions, respectively. The term P_∞ in Equation 3.7 is given by Equation 3.8:

$$P_\infty = \frac{A}{1 + \beta W_s} \quad [3.8]$$

where, A and β are constants. Equation 3.8 shows that the stronger pavements (small W_s) would be less affected by environmental forces than weaker pavements.

The final equation for calculating the environment-associated performance loss in the OPAC model is:

$$\Delta RCI_E = \left(RCI_0 - \frac{RCI_0}{1 + 2.3622W_s} \right) (1 - e^{-0.06Y}) \quad [3.9]$$

In the new OPAC 2000 method, the equations for estimating the performance loss due to environmental factors have different magnitudes for parameters associated with subgrade deflection (W_s) and pavement age (Y). In the OPAC 2000, pavement condition is measured by PCI as shown by Equation [3.10].

$$\Delta PCI_E = \left(PCI_0 - \frac{PCI_0}{1 + \beta W_s} \right) (1 - e^{-\alpha Y}) \quad [3.10]$$

where, β and α have magnitudes as shown in Table 3.3. The table also represents the R-Square (R^2) and Sum of Squared Error (SSE) values associated with different models.

Table 3.3. OPAC 2000 Parameters (He et al., 1995)

Parameter	OPAC 2000		Original OPAC
	Southern Ontario	Northern Ontario	
β	12.7211	10.5478	2.3622
α	0.0329	0.0415	0.06
R^2	0.707	0.866	-
SSE	2.966	0.383	South 3.262 North 0.905

In the OPAC 2000 model the performance of the pavements with overlay is estimated based on the similar procedures used for new pavement structures. However, the equivalent granular pavement thickness, H_e , is modified to represent the structural strength of the distressed pavement based on the following equation:

$$H_e = a_1 h_0 + a'_1 h_1 + a'_2 h_2 + a'_3 h_3 \quad [3.11]$$

where,

a_1 = equivalency factor (GBE) of the new material,

a'_1, a'_2, a'_3 = discounted GBE's for old asphalt, granular base and subbase layers, and

h_0, h_1, h_2, h_3 = overlay thickness and old layer thicknesses.

The OPAC 2000 pavement performance prediction equations have been used in this research for analyzing the pavement costs for reviewing the effects of the technical and economic characteristics of pavements on pavement life-cycle costs in Ontario.

3.3.2. Load Equivalency Factors

The Canadian Vehicle Weights and Dimensions Study (RTAC, 1986) was carried out to quantify pavement damage caused by heavy vehicles. The test identified Load Equivalency Factors for steering, single, tandem and tridem axles as shown in Figure 3.4. Although the test showed a wide variation in the LEFs, the results in general were found to be in compliance with AASHO road test.

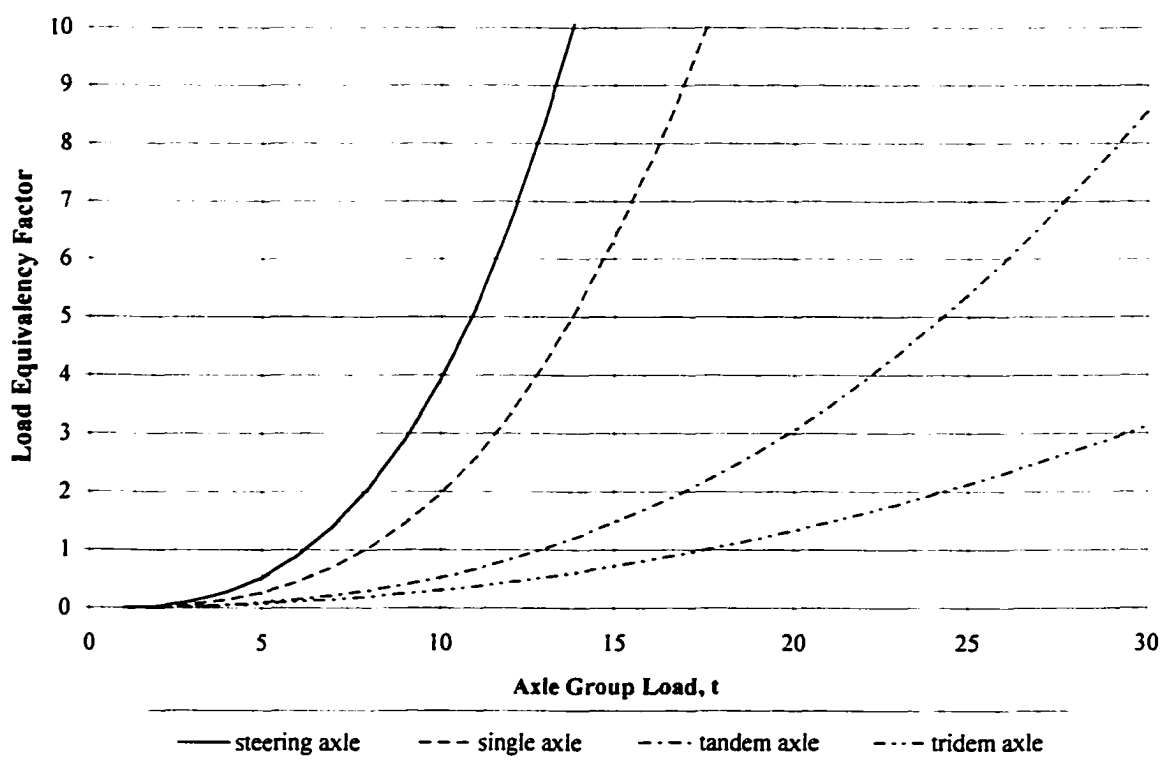

Figure 3.4. Load Equivalency Factors from Canadian Weights and Dimension Study (RTAC, 1986)

The Load Equivalency Factors (or ESALs) shown in Figure 3.3 can be represented by the following equations:

$$\text{Steering Axle:} \quad LEF = 0.004836 \times load^{2.9093} \quad [3.12]$$

$$\text{Single Axle:} \quad LEF = 0.002418 \times load^{2.9093} \quad [3.13]$$

$$\text{Tandem Axle:} \quad LEF = 0.001515 \times load^{2.5403} \quad [3.14]$$

$$\text{Tridem Axle:} \quad LEF = 0.002363 \times load^{2.1130} \quad [3.15]$$

These equations are used to calculate ESALs associated with different vehicles in this research. The calculated vehicle ESALs are presented in Chapter 5 for different vehicle groups carrying different amount of payloads and operating on different road classes.

3.4. PAVEMENT LIFE-CYCLE COSTS

The goals of the pavement cost analysis are to make rational choices of pavement design and maintenance both at the project and network levels and to make sure that funds for road construction and maintenance are expended efficiently. Road agencies often use the pavement life-cycle cost analysis to obtain the optimal pavement designs and rehabilitation strategies by minimizing the pavement life-cycle costs (TAC, 1997).

Figure 3.5 illustrates a typical cost profile associated with pavements. As illustrated in the figure, costs throughout the life of the pavements are mainly: *i*) construction costs, *ii*) rehabilitation costs, and *iii*) periodic maintenance costs. Construction costs are usually high compared to maintenance and rehabilitation costs and depend on the initial pavement structural design. Stronger pavements cost more but they have longer lives. Therefore, life-cycle cost analyses should be carried out in order to obtain an optimal pavement design. The present worth method is used for the life-cycle cost analysis in this research by discounting all the costs back to the present.

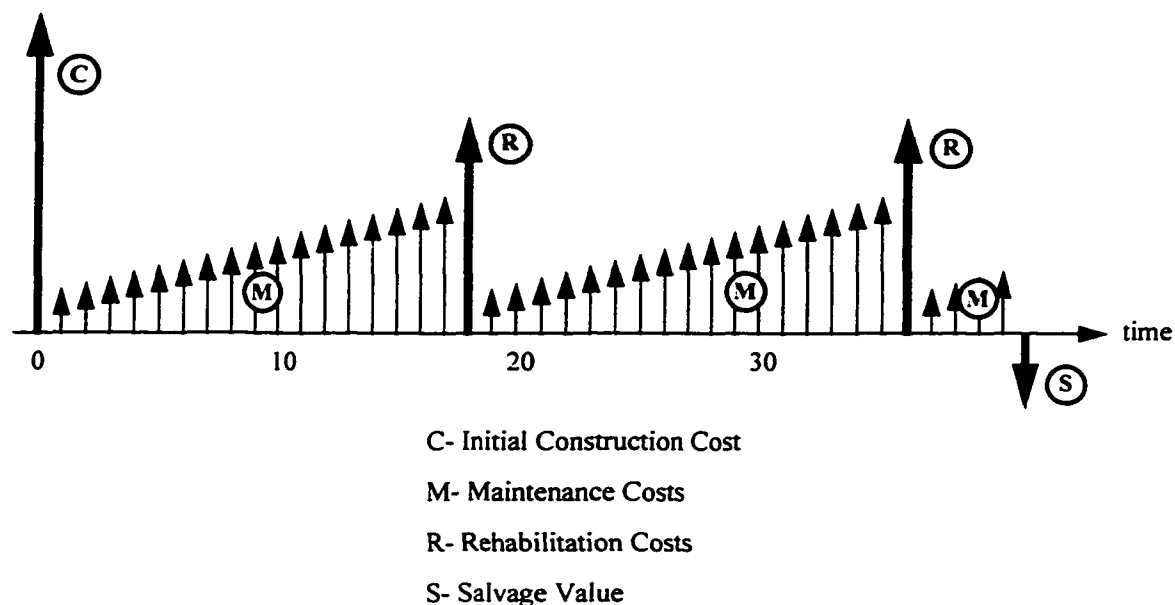

Figure 3.5 Pavement Cost Structure

There may be some remaining life associated with a pavement section at the end of the analysis period and this may be denoted as a salvage value. The pavement salvage value may be calculated by discounting the costs associated with the last major activity to annual costs for the period of expected life of pavement after the last rehabilitation. Then, the remaining costs associated with the portion of time that is not used will be discounted back to present time and subtracted from the total costs.

3.5. FRAMEWORK AND ASSUMPTIONS OF PAVEMENT COST ANALYSIS

3.5.1. Framework of Cost Analysis

Several computer programs have been developed during this research to carry out the economic analysis of pavements. These programs have been written in C++ language. The major module of these computer programs calculates the life-cycle costs of individual pavement sections.

The inputs and outputs of the computer module are shown in Figure 3.6. The inputs include the pavement structural specifications (i.e., asphalt, base and subbase layer thicknesses), subgrade and granular material properties, number of ESALs in the first year and the age of the pavement.

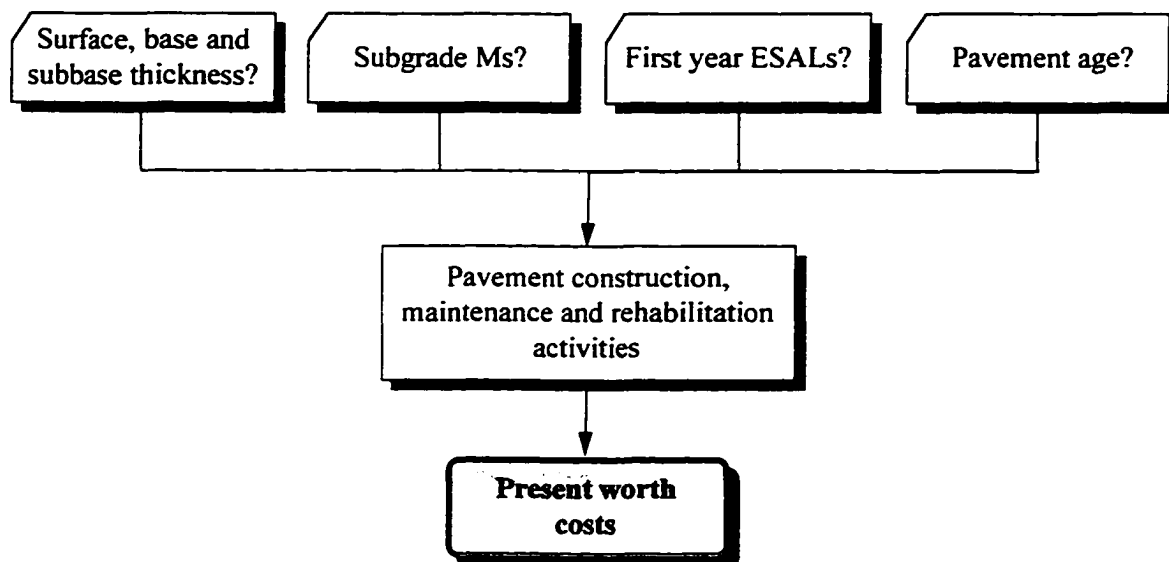

Figure 3.6. Inputs and Outputs of the Pavement Cost Analysis Module

In the pavement cost analysis module, each pavement section is considered as a unique object which has several attributes such as pavement layer thicknesses and subgrade strength. Based on the OPAC 2000 pavement performance prediction equations, the program calculates the future condition of the pavement at different points of time. The program finds the optimal pavement strategies at different points of time, whether it should be a routine maintenance or a major resurfacing or a complete reconstruction. These decisions should be made based on specific criteria. For example, there must be specific limits for minimum pavement riding comfort level or maximum number of resurfacings. Generally, in this research the decision criteria have been

adopted from the guidelines suggested by MTO and the actual criteria used in practice. These assumptions and standards are described in the next sections.

Figure 3.7 illustrates the structure of the pavement cost analysis module in more detail. The inputs consist of traffic data, pavement structural specifications, subgrade and granular material modulus of elasticities, and the current age (which may be used to find the condition of the pavement at the time of analysis) of each pavement section.

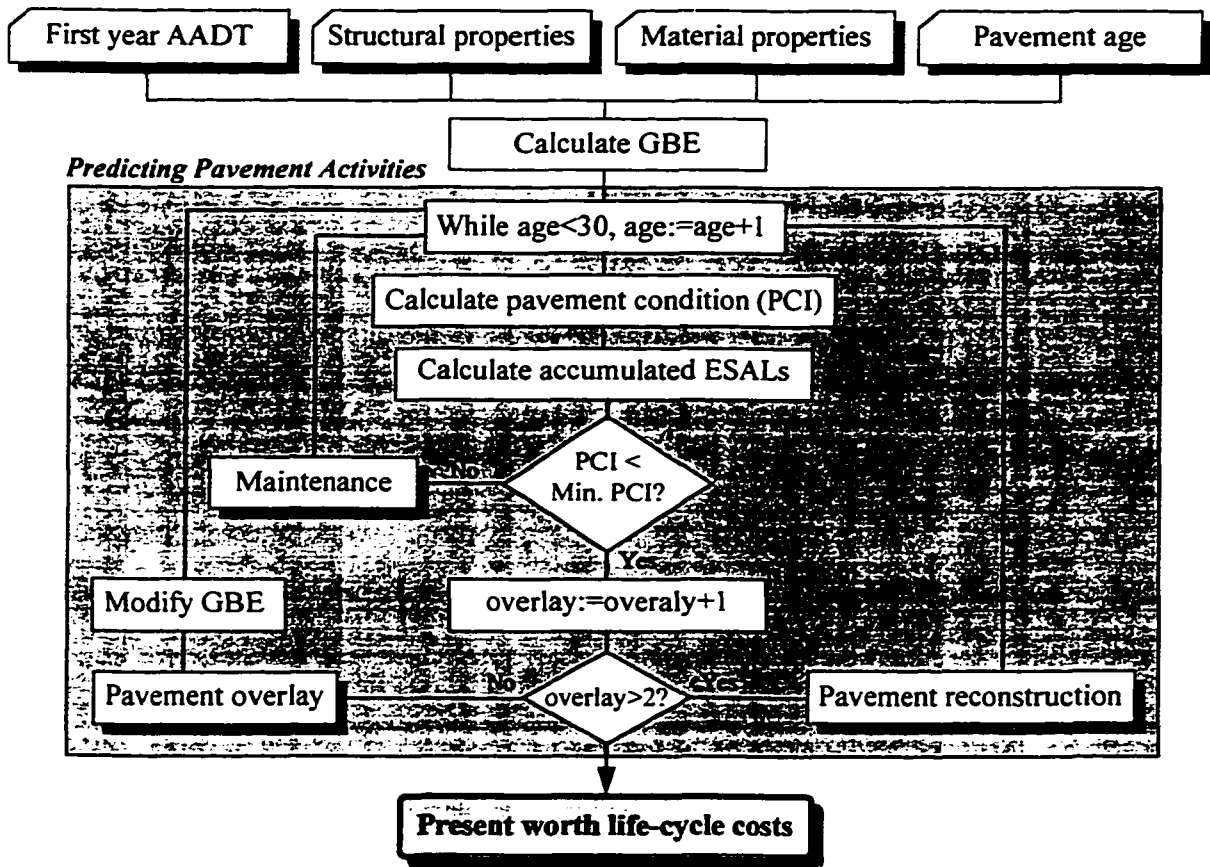

Figure 3.7. Procedures for Pavement Life-Cycle Cost Analysis

First, the thicknesses of the surface, base and subbase courses are converted to the granular base equivalent thickness (GBE) which is required for calculating the subgrade deflection. Using the OPAC 2000 equations, the pavement condition index (PCI) of each pavement is calculated for different points of time for 30 years of life. The pavement

conditions are compared with the minimum acceptable PCI and decisions are made if there should be any maintenance activity over the life of the pavement. In practice, the pavements are rehabilitated after their PCI drops below a certain limit. However, usually after the second overlay, when pavement condition drops below the minimum PCI again, pavements will be reconstructed. According to the current practice by MTO, it is assumed that the PCI of a new pavement is about 85 and the minimum acceptable PCI for major highways, arterial and collector roads are 55, 50 and 45, respectively.

It is also assumed that the qualities of pavement materials decrease over time. This may affect the predictability of pavement performance models after the pavement condition is improved to the original level (after pavement overlay is placed). To reflect the decline in the pavement material properties, after the pavement is overlaid, the original pavement GBE is modified for the next series of calculations after each rehabilitation activity takes place. This is done by reducing the original GBE factors for old materials to certain fractions of their original GBE factors shown by Equation [3.11].

After estimating the pavement condition and activities, the next step is to calculate the costs associated with pavement materials and activities. All costs associated with each pavement activity including the construction, maintenance and rehabilitation costs are converted to present worth and are added. The results of the analyses are summarized in the following sections.

3.5.2. Characteristics of Ontario Pavements

A typical design for flexible pavements for average traffic conditions and for regular subgrades in Ontario may consist of 50 to 200 mm of asphaltic surface course (including dense friction course), 100 to 200 mm granular base and 150 to 1000 mm of lesser quality granular sub-base. As explained before, the main goal of pavement design procedures is to compromise the higher initial costs of strong pavements with the higher maintenance costs of weak pavements which can be accomplished by minimizing the total life-cycle costs of pavements.

To carry out the life-cycle cost analysis for Ontario pavements in this chapter, it is assumed that 150 mm of granular material is used, as suggested by the Ontario Pavement Design and Rehabilitation Manual (1990). Also, hot mix layer thicknesses are fixed for different roads according to their traffic level. Table 3.4 summarizes the thickness of hot mix asphalt used for different roads with different annual ESALs. The thickness of subbase material is assumed to be the principal variable component.

Table 3.4. Asphalt Hot Mix (HM) Course Thickness for Different Traffic Situations

Number of ESALs/year	HM, mm
>1,000,000	150
800,000-1,000,000	150
600,000-800,000	140
400,000-600,000	130
200,000-400,000	130
100,000-200,000	90
50,000-100,000	50
<100,000	50

Subgrade material properties (measured by modulus of elasticity) affect the optimal thickness designs. Table 3.5 shows typical subgrade modulus of elasticities for different subgrade types in Ontario.

Table 3.5. Modulus of Elasticity of Different Subgrade Types in Ontario

Soil Type	M_s , MPa
Gravel and Sand	76
Silt(<40%)	42
Silt(40-55%)	35
Silt(>55%)	28
Lacustrine Clay	35
Varved and Leda Clay	24

Table 3.6 shows the typical unit costs for pavement construction. These costs include all costs related to the pavements including material, preparation and labour costs. These costs are used to carry out the pavement cost evaluation in this research. These costs have been collected by personal contacts with different sources in the Pavement Management Office of MTO. The average overlay cost is assumed to be \$10/m² of road surface area. Also, the annual maintenance costs are assumed to average \$720/km for a single-lane road. It is also assumed that the material and labour costs are about 6 to 12 percent higher in Northern Ontario depending on the road types.

Table 3.6. Unit Costs of Pavement Construction

Item	Cost	Unit
Dense friction course	\$130	per km- 1 m width- 1 mm depth
Asphalt course	\$80	per km- 1 m width- 1 mm depth
Open graded drainage layer	\$58	per km- 1 m width- 1 mm depth
Granular A	\$20	per km- 1 m width- 1 mm depth
Granular B	\$15	per km -1 m width- 1 mm depth

Also, for the purpose of the cost analysis in this research, it is assumed that traffic grows by the rate of 2 percent each year. Also, the annual discount rate has been assumed to be equal to 5 percent. This rate is the basis for discounting the road costs to present values in this research.

3.6. COST EVALUATION OF ONTARIO PAVEMENTS USING OPAC 2000

3.6.1. Analysis Goals

This section investigates the economic characteristics of some representative pavement sections in Ontario using the OPAC 2000 equations. The first series of investigations is devoted to sensitivity analyses of pavement life-cycle costs versus pavement thickness for some typical pavements for various traffic conditions and

subgrade types. The second series of analyses investigates the relationships between the initial design of pavement thickness and pavement initial life as well as pavement life-cycle costs. The results of these analyses are described in the following subsections.

3.6.2. Optimal Pavement Designs

Analyses have been carried out in this section to investigate the optimal pavement thicknesses for different subgrade types, traffic situations and structural specifications in Ontario. Figures 3.8 to 3.11 show the present worth pavement life-cycle costs versus initial pavement thickness for several pavement sections with different levels of traffic volumes and for different subgrade strengths. The optimal pavement designs may be observed from them. The pavement life-cycle cost curves are calculated and shown for extreme conditions in terms of traffic levels and subgrade conditions. The implications of these analyses are explained in the following paragraphs.

It may be observed from the figures that if initial pavement thickness is less or greater than the optimal thickness, there will be an increase in the total life-cycle costs. However, the rate of increase in total costs may not be the same for pavements which are underdesigned as compared to those overdesigned.

As can be observed from the figures, underdesigning pavements seems to have a much more significant rate of increase in total costs compared with overdesigned pavements, especially in the case of weak subgrades. For example, for a subgrade with modulus of elasticity of 24 MPa and high traffic volume, the optimal GBE is about 1200 mm. In this case, a 20 percent decrease in the GBE would increase the total costs by 35 percent, while increasing the GBE by 20 percent would increase the total costs by less than 5 percent.

The sensitivity of pavement costs to underdesigning the pavement thickness may be explained by the fact that thinner pavements require more frequent rehabilitation and maintenance and the extra costs of increase in initial thickness would be compensated by savings in the rehabilitation and maintenance costs during the pavement life.

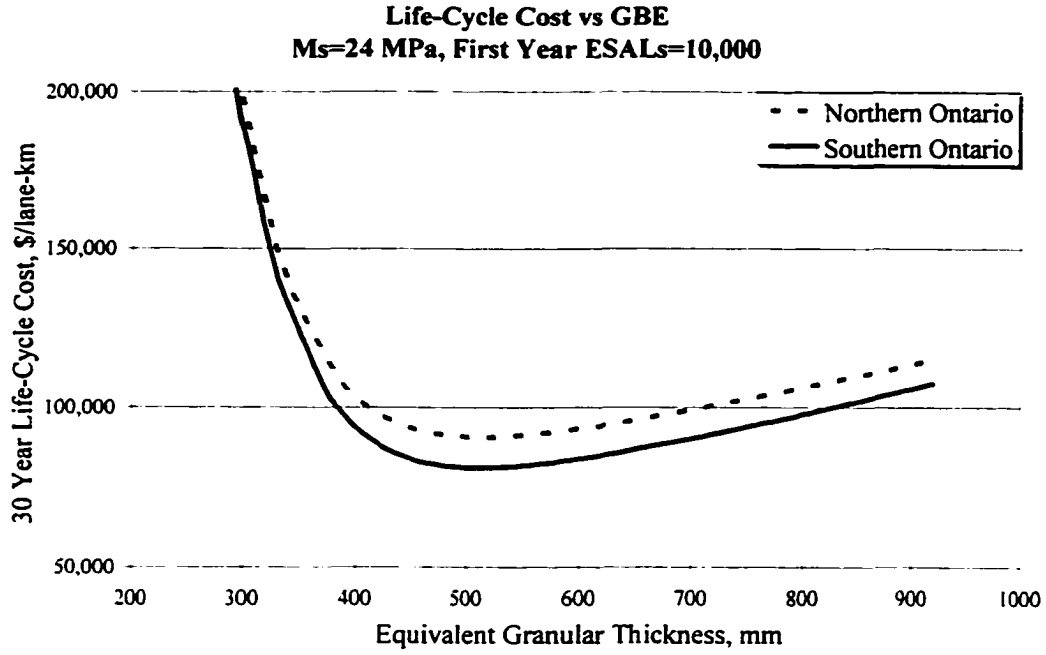

Figure 3.8. Life Cycle-Costs for a Low Volume Road on a Weak Subgrade

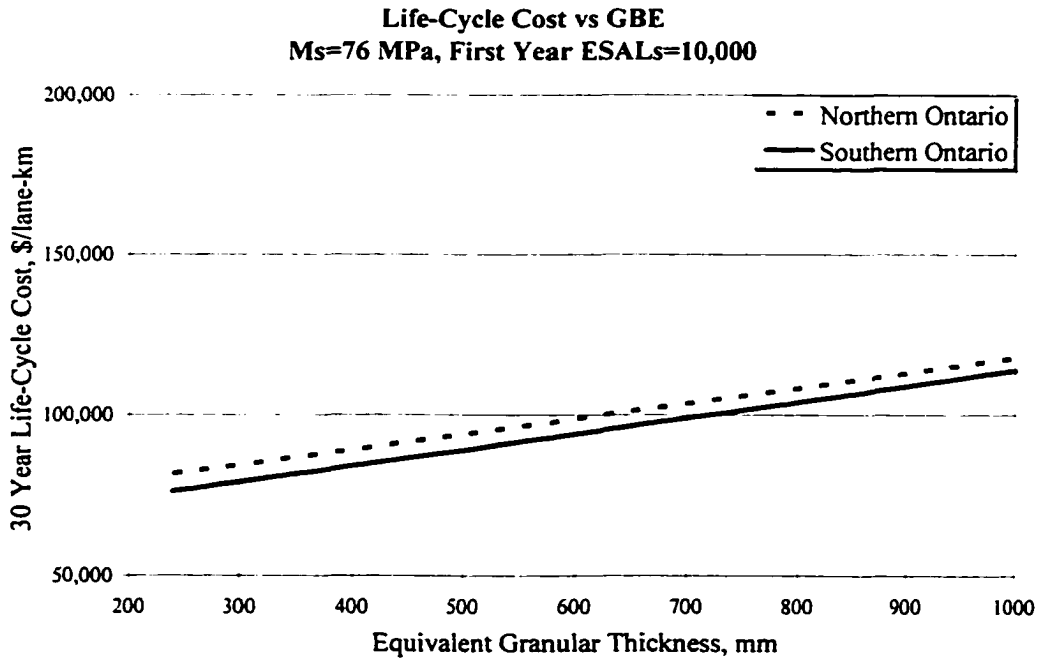

Figure 3.9. Life Cycle-Costs for a Low Volume Road on a Strong Subgrade

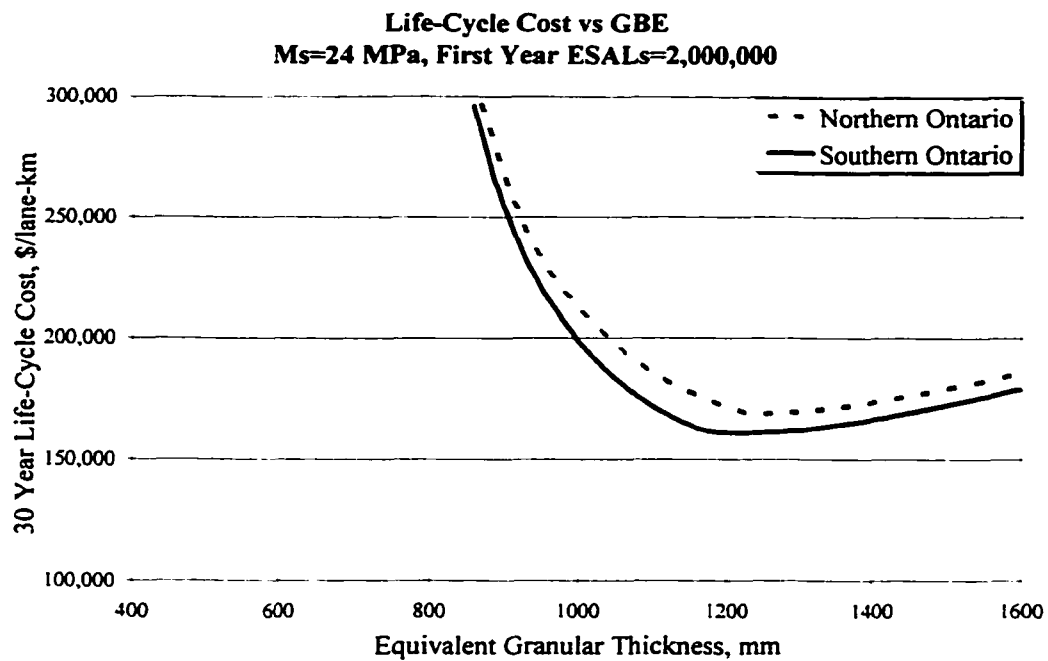

Figure 3.10. Life Cycle-Costs for a High Volume Road on a Weak Subgrade

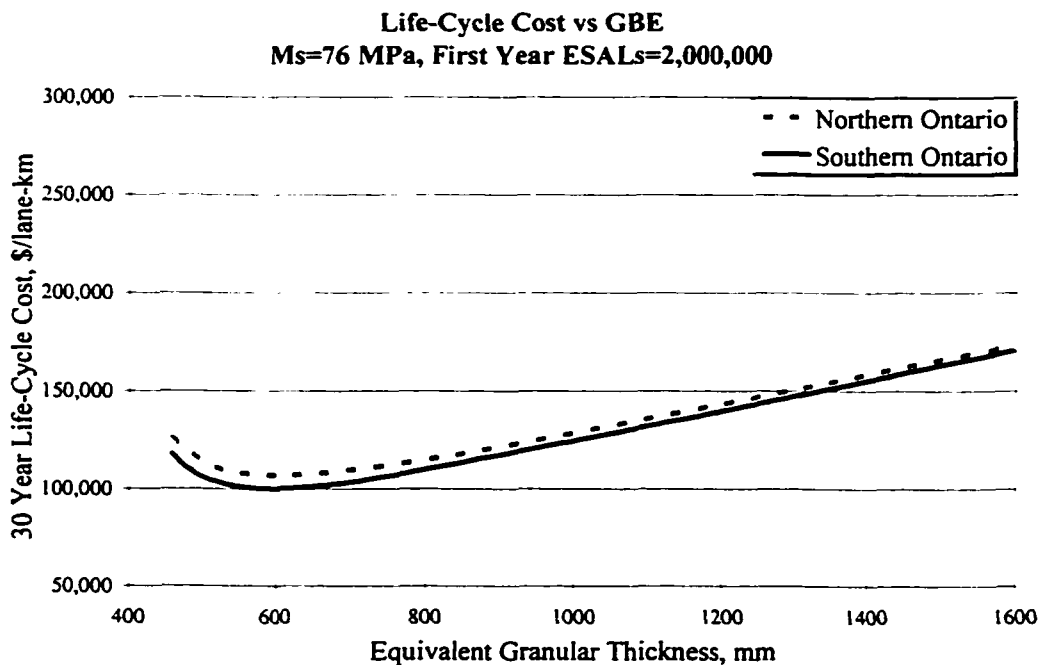

Figure 3.11. Life Cycle-Costs for a High Volume Road on a Strong Subgrade

The figures also illustrate that a pavement section in Southern Ontario has a lower life-cycle cost than a pavement section with similar traffic and subgrade conditions in Northern Ontario. This reflects the harsher climatic conditions in the Northern Ontario that tend to accelerate pavement deterioration. Also, it can be observed from the figures that weak subgrades ($M_s=24$ MPa) may result in more than 60 percent increase in costs compared to strong subgrades ($M_s=76$ MPa), for the same traffic level.

Also, Figures 3.8 to 3.11 indicate that the scale economies exist in pavement life-cycle costs versus number of ESALs applied to the pavements during their life. For example, increasing ESALs by 200 times (from 10,000 to 2,000,000 ESALs/year) cause the costs to increase by 80 percent which implies lower average costs per ESAL for higher volume roads.

Figure 3.12 shows the initial pavement construction costs versus initial pavement life for a pavement section on a fair subgrade (i.e., $M_s=42$ MPa). It may be observed from the figure that a small increase in initial investment may cause significant increases in initial life of the pavements. For example, for a high volume road, an initial cost increase of 15 percent may increase the initial life of the pavement from 5 years to 10 years and another 20 percent may extend the initial pavement life to 15 years. Also, it may be observed from the figure that the rate of increase in initial pavement costs versus initial pavement life is almost linear until the optimal initial pavement life after which the rate of change increases.

The total life-cycle costs of pavements are also influenced by initial pavement thicknesses. The relationship between the pavement initial life and the pavement life-cycle costs is illustrated in Figures 3.13 to 3.16. The figures show the life-cycle costs versus initial pavement life for pavements with different traffic and subgrade conditions.

It may be concluded from the figures that optimal initial pavement life is about 15 years in Northern Ontario and a little more for pavements in Southern Ontario, about 17 years. Specifically, for high volume roads and strong subgrades, the optimal initial pavement life is between 17 to 20 years. This situation usually happens for high volume

commuter highways that exist within urban jurisdictions. This may justify the construction of high quality pavements that provide longer initial life for high traffic volume pavements.

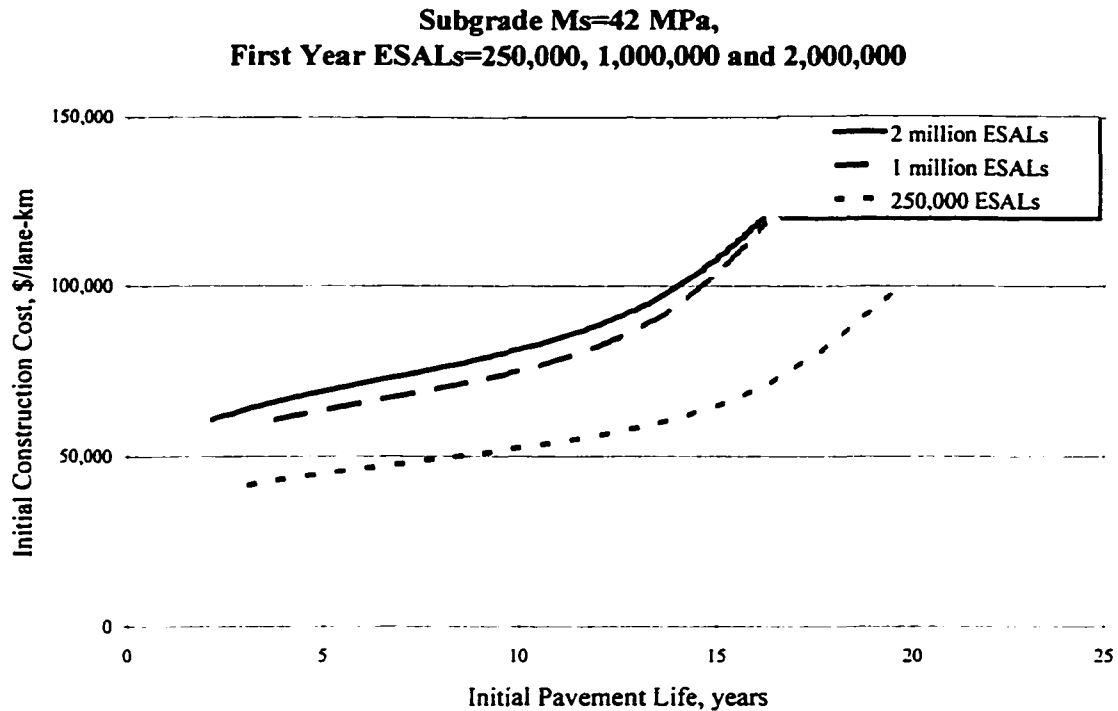

Figure 3.12. Initial Construction Costs vs Initial Pavement Life

It may be observed from the figures that pavement deterioration due to climatic effects is greater in Northern Ontario than in Southern Ontario. These effects become more important for thicker pavements (when comparing environment-associated degradation with traffic-associated degradation) which are relatively unaffected by traffic. This is due to the fact that fatigue capacity of pavements increases exponentially with increasing pavement thickness which causes the effects of traffic factors to become less important relative to the effects of environmental factors. This is illustrated in the figures where the life-cycle costs for pavements in Northern Ontario increase at a faster rate than for Southern Ontario with increasing initial pavement thickness.

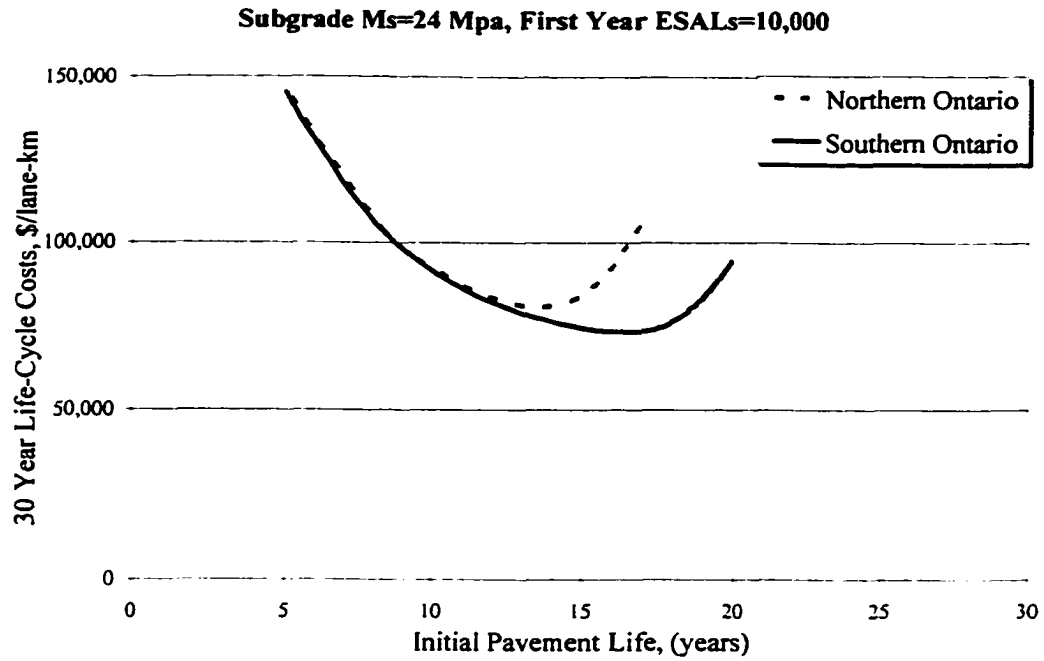

Figure 3.13. Costs vs Initial Life for a Low Volume Road on a Weak Subgrade

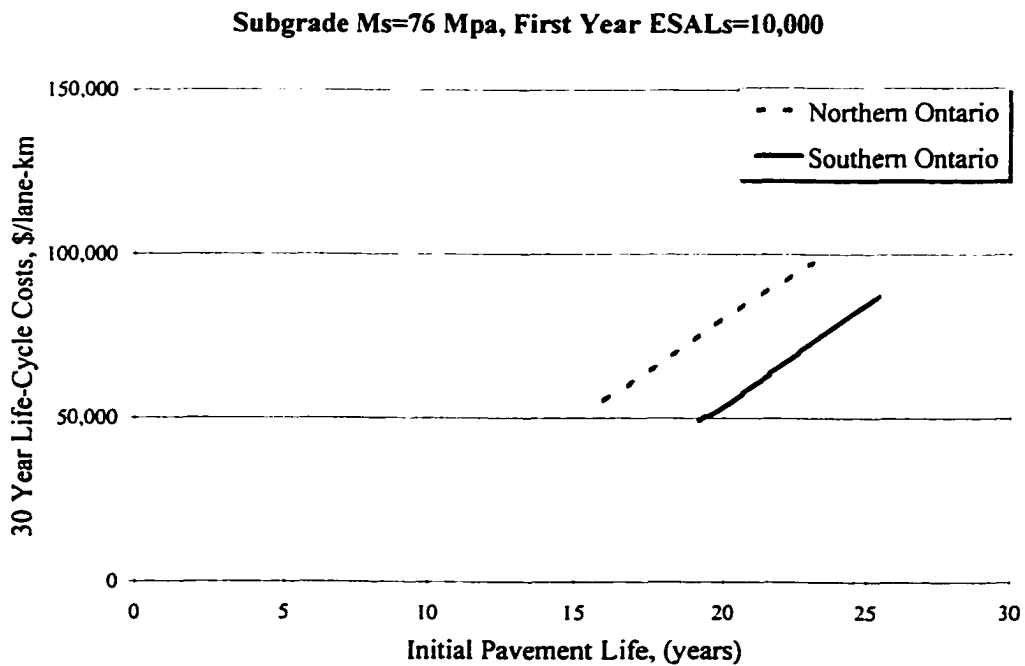

Figure 3.14. Costs vs Initial Life for a Low Volume Road on a Strong Subgrade

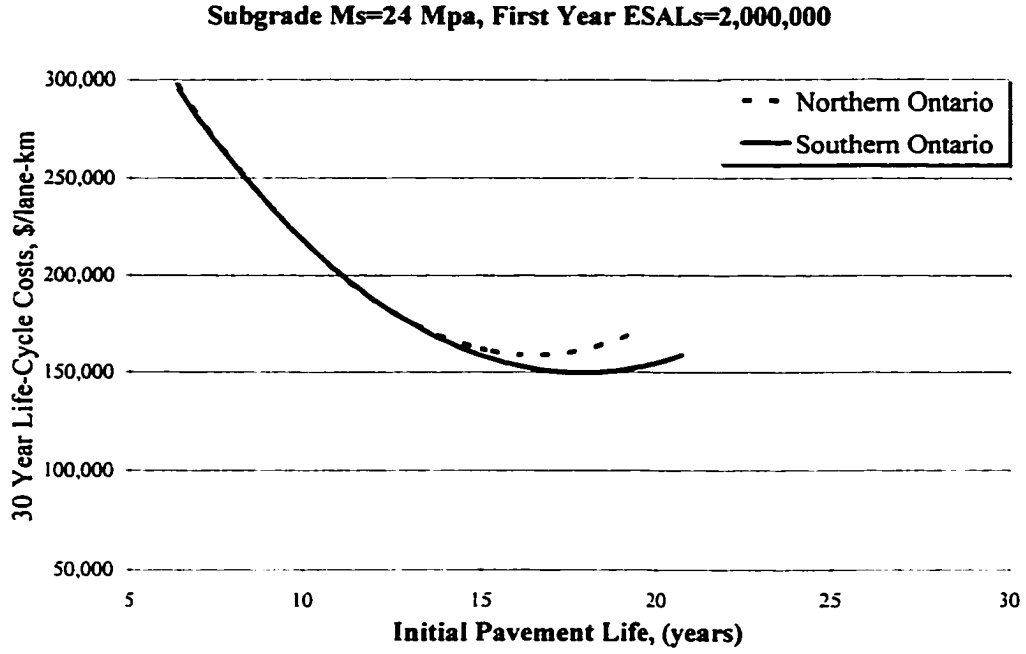

Figure 3.15. Costs vs Initial Life for a High Volume Road on a Weak Subgrade

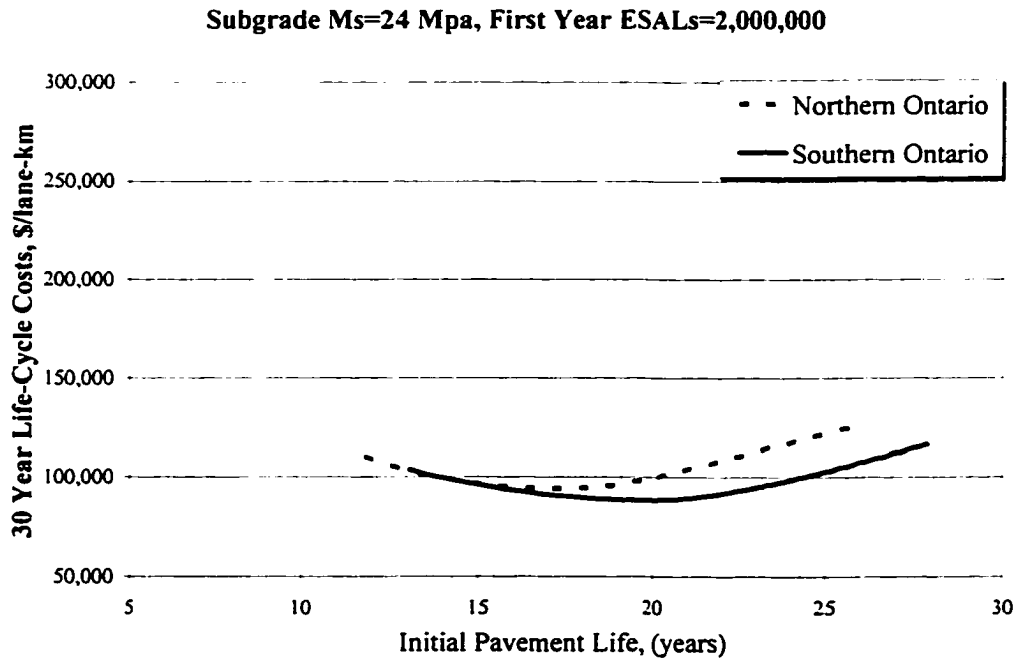

Figure 3.16. Costs vs Initial Life for a Low Volume Road on a Strong Subgrade

Figure 3.17 illustrates the cost effects of environment and traffic separately for a typical pavement in Ontario with annual ESALs of 250,000 and subgrade M_s of 42 MPa. The environmental associated pavement costs represent the costs associated with only environmental factors disregarding the effects of traffic loadings. The figure clearly shows that as the initial pavement thickness increases the costs associated with environmental degradation increase while the traffic associated costs decrease. It can be seen from the figure that at the optimal pavement thickness the environment-associated costs account for about 70 percent of total pavement costs.

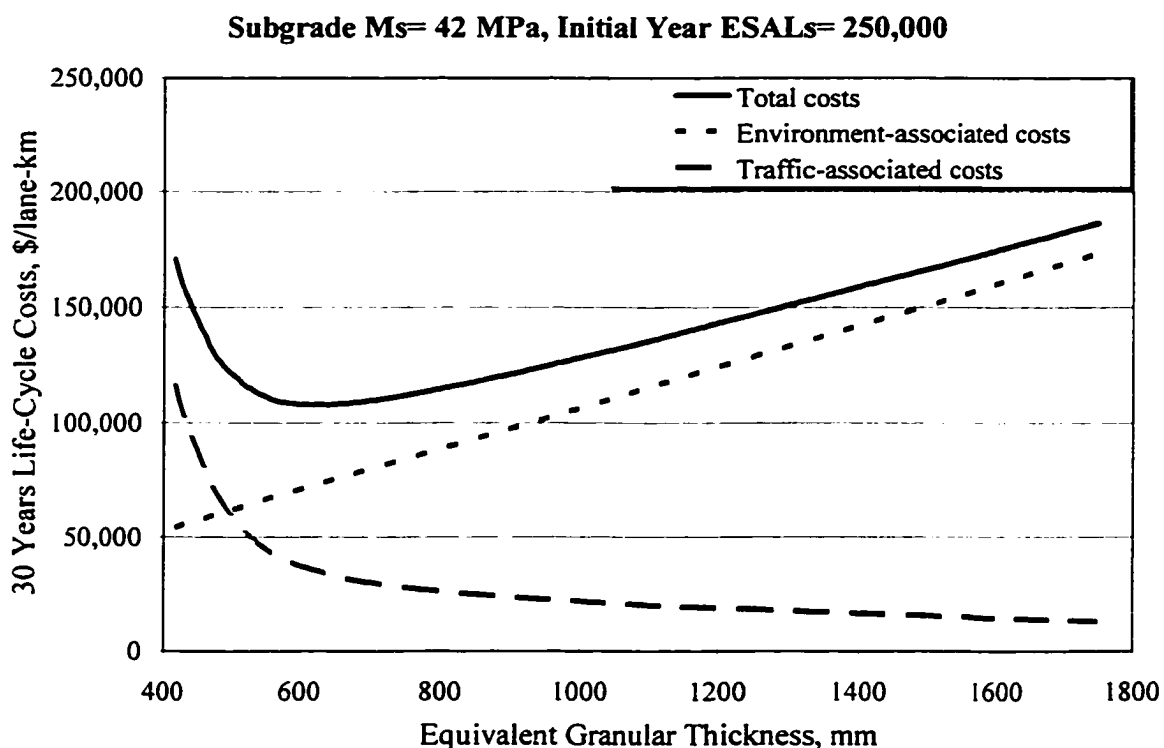

Figure 3.17. The Cost Effects of Environment and Traffic on Pavement Costs

Figure 3.18 summarizes the results of the above analyses for different traffic levels. It may be seen that with a little increase in investments, pavements can withstand significantly more ESALs during their lives. This clearly implies that scale economies

exist in pavements. As illustrated by the figure, for optimum pavement design, a road with 250,000 annual ESALs requires about \$120,000/lane-km, while it would cost about \$150,000 and \$160,000/lane-km to build and maintain roads with 1 million and 2 million annual ESALs, respectively.

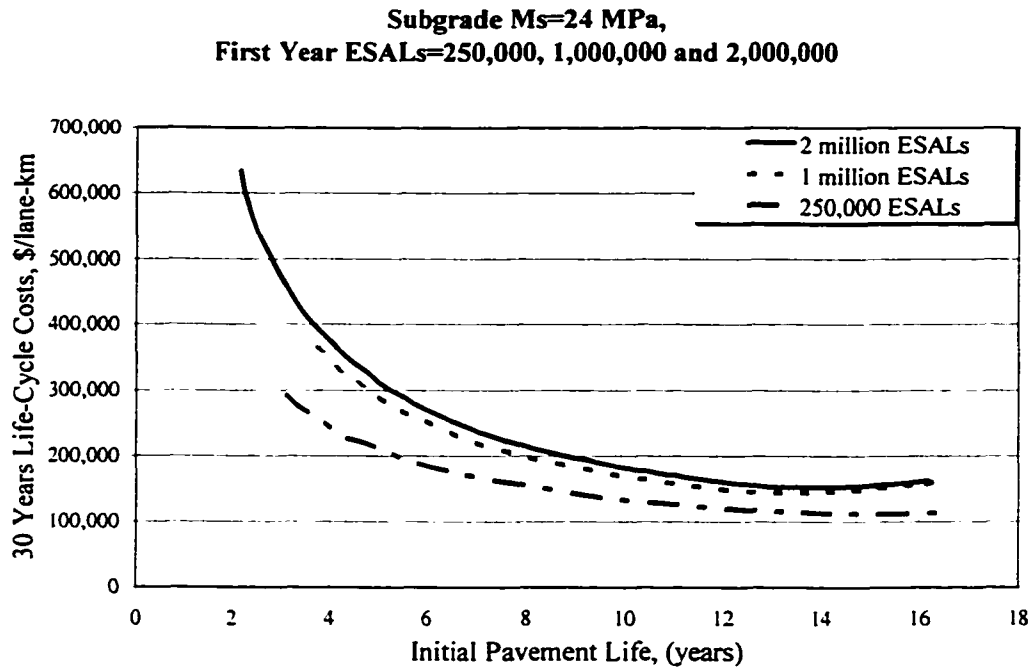

Figure 3.18. Life Cycle-Costs vs Initial Pavement Life for different traffic levels

Figure 3.19 illustrates the pavement life-cycle costs per lane-kilometre versus the total number of ESALs for the cost minimizing initial design. It may be observed from the figure that the cost curves increase at a decreasing rate. The figure also confirms that the pavement costs in Northern Ontario are higher than in Southern Ontario. Also, it may be observed from the figure that the difference between pavement life-cycle costs in Northern and Southern Ontario would account for about 15 percent for low volume roads, while this difference is less for higher volume roads, about 6 percent.

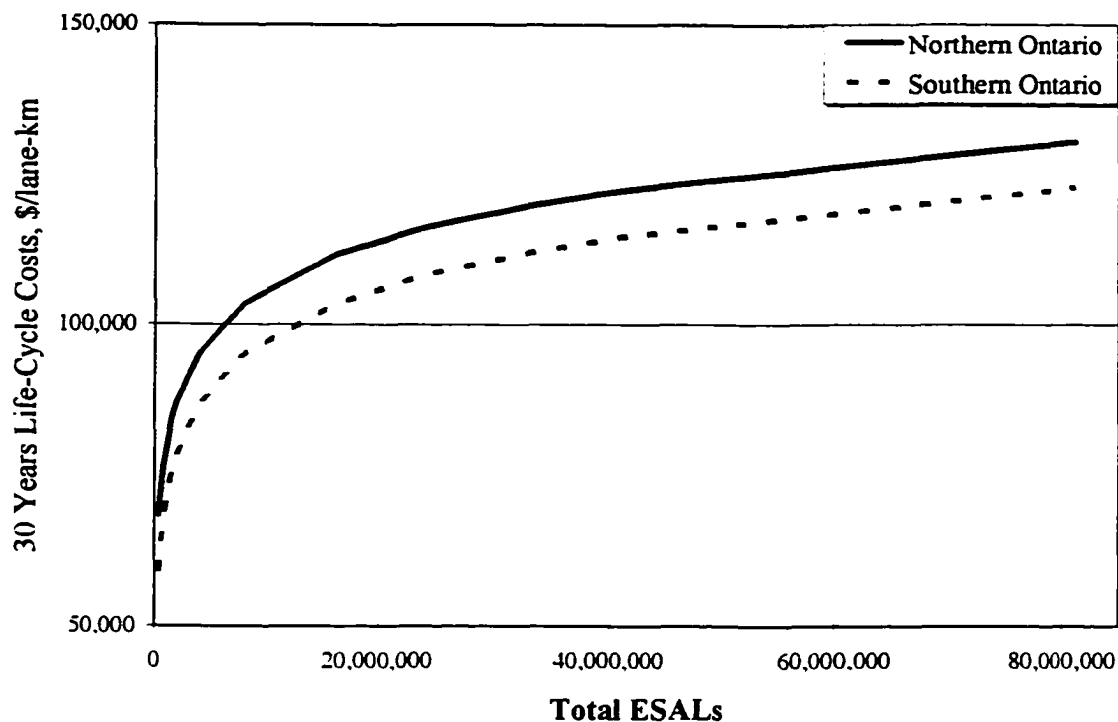

Figure 3.19. Life Cycle-Costs vs Total ESALs

Figure 3.20 and 3.21 illustrate the pavement total life-cycle costs as well as environment-associated costs versus the total ESALs for pavements in Northern and Southern Ontario, respectively. It may be observed from the figures that the percentage of environment-related costs to the total life-cycle costs are different in Northern and Southern Ontario with a higher percentage of environment-related costs to total costs in Southern Ontario. One of the reasons that the percentages of the environment-related costs are higher in Southern Ontario is that the total pavement costs are lower in the southern regions and therefore the percentages of the environmental associated costs become higher.

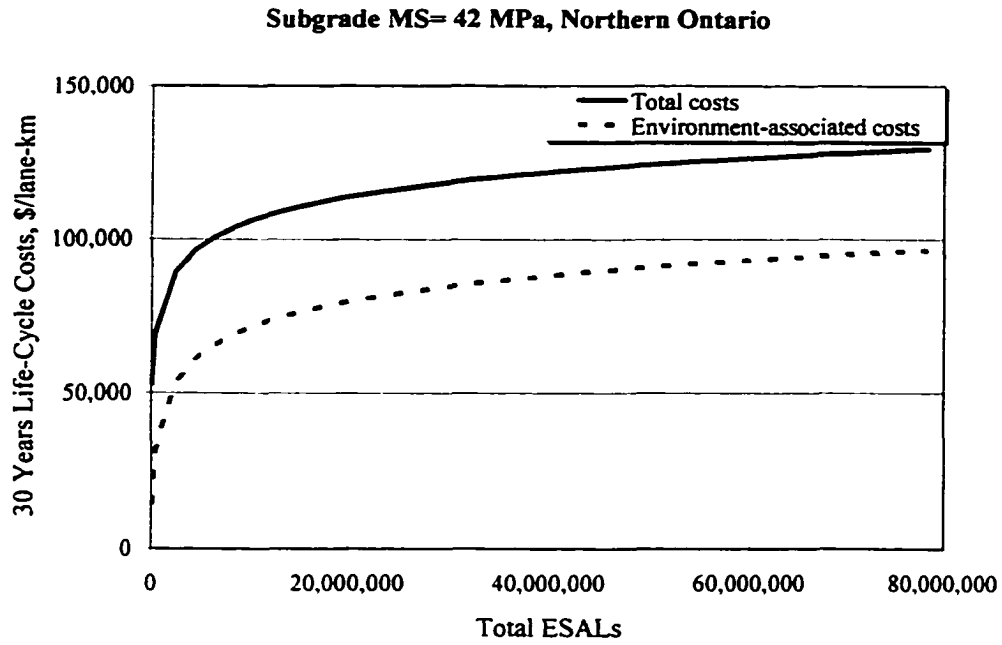

Figure 3.20. Environment and Traffic Costs vs Total ESALs, Northern Ontario

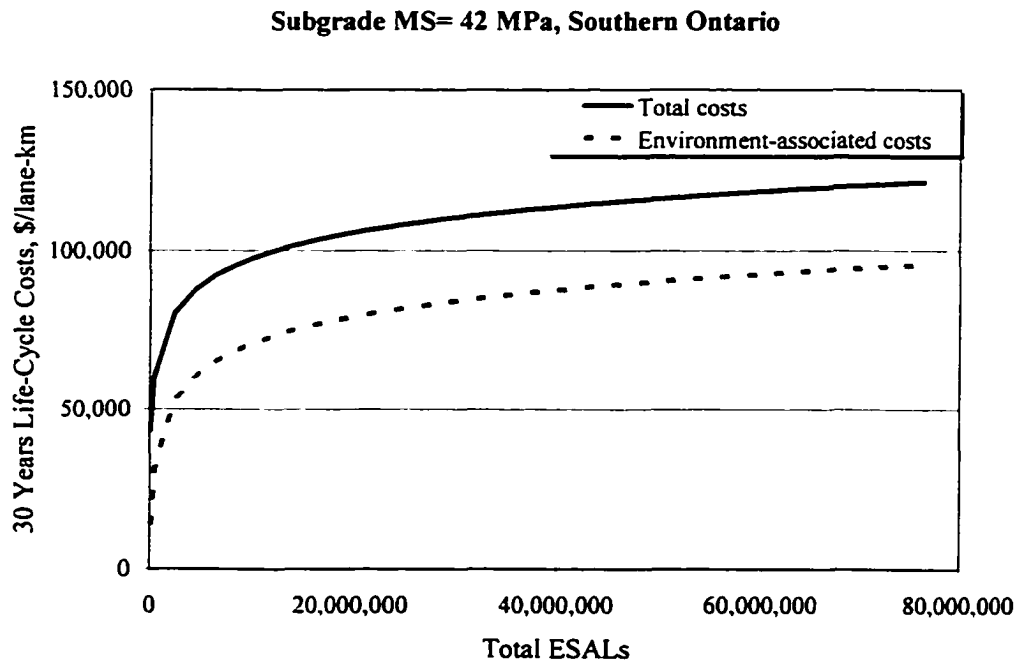

Figure 3.21. Environment and Traffic Costs vs Total ESALs, Southern Ontario

In summary, the cost analyses of the typical pavement sections in Ontario described in this chapter shows the effects of different factors such as environment and traffic on pavement deterioration. Different levels of traffic as well as different pavement thickness designs can significantly influence the economic characteristics of pavements. The analyses also showed that variations in subgrade type may influence pavement life-cycle costs significantly. Also, the design of pavement thickness was shown to have a significant effect on the pavement initial life and consequently pavement life-cycle costs. These may imply that pavement cost analysis should be carried out at the network level and roads should be classified for cost allocation analysis. The cost analysis for pavements at the network level is carried out in the next chapter.

CHAPTER 4

Marginal Pavement Costs in Ontario

4.1. INTRODUCTION

The major goal of this chapter is to develop a proper classification of road users and to estimate their marginal pavement damage costs for the purpose of cost allocation analysis. The cost analyses for typical pavement structures explained in the previous chapter showed that pavement life-cycle costs are significantly different for roads with different physical characteristics and different climatic and traffic conditions. Hence, due to diversity in environmental and traffic conditions across Ontario, pavement costs and user cost responsibilities vary for different road and vehicle types. To arrive at fair and efficient road prices and in order to identify reliable classifications of road users, it is important to analyze the economic characteristics of roads and vehicles at the network level.

This chapter begins with a review of the available information and databases about road characteristics in Ontario. The procedures employed for estimating and analyzing the life-cycle, marginal and average costs of the pavements are also described. The conclusions and implications of the cost analyses are explained and discussed at the end of this chapter.

4.2. DESCRIPTION OF THE DATA BASES

The major source of information used for the cost analysis of pavements in this chapter is MTO's Highway Inventory Management System (HIMS) data base (MTO, 1995). The data base contains geometric and traffic information for more than 3500 pavement sections in Ontario including name, location, number of lanes, functional classes, percentage of commercial vehicles, and the length of pavement sections. However, 2886 data lines of the HIMS data base contain information on major highways (i.e., King's Highways) and are used for the pavement cost analysis in this chapter.

The HIMS database did not include information about pavement subgrade and structural specifications. However, the subgrade types and structural specifications associated with some of the pavement sections of the HIMS database were available from MTO's Pavement Management System (PMS) database.

The PMS database was used to complement the pavement attributes in the HIMS database with subgrade information. However, the subgrade information was available for only a part of the 2886 pavement sections used in the cost analysis. Therefore, it was assumed that subgrade types of these pavement sections were correlated with the adjacent road sections. Therefore, if the subgrade type of a pavement section was not available in the PMS database, the subgrade type of the closest pavement section was attributed to that pavement sample.

In addition to the subgrade and traffic conditions, the pavement layer thicknesses and properties were also required for the purpose of the life-cycle cost analysis. However, that type of information was not also available for all pavement samples in either of the databases. To solve this problem, some equations based on the Ontario Pavement Design and Rehabilitation Manual were developed to estimate the thickness of the different pavement layers. Those estimates were then attributed to each pavement section.

4.3. COST ANALYSIS PROCEDURES

Figure 4.1 illustrates the general framework for the system-wide analysis of pavement costs. The HIMS and PMS databases are first combined to complement each other. To accomplish the analysis three major steps were taken including: *i)* estimating the unknown parameters, *ii)* estimating pavement cost components such as total, marginal and average costs, and *iii)* generalizing and tabulating the results.

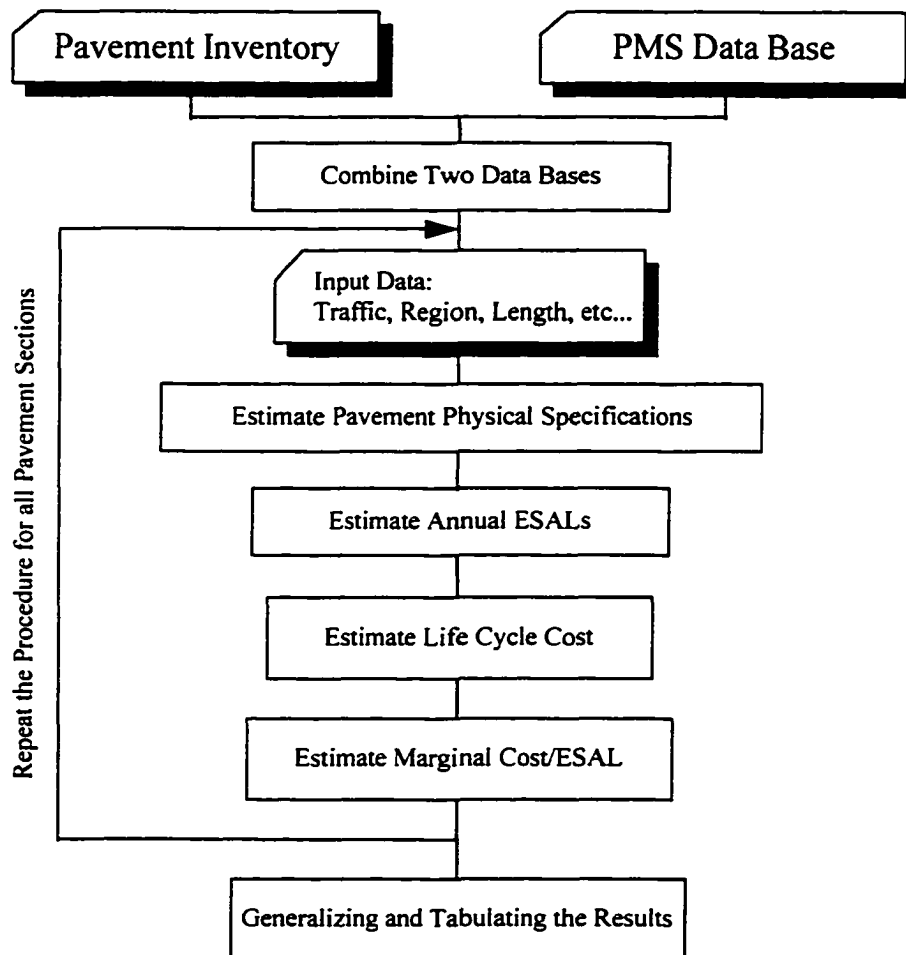

Figure 4.1. General Steps for System-Wide Pavement Cost Analysis

As explained before, neither the HIMS database nor the PMS database contained information on the pavement layer thicknesses of many of the pavement sections of those data bases. The missing information is estimated based on MTO's guidelines and using regression models that are established in this research. MTO originally has given the asphalt layer specifications for several ranges of traffic volumes (MTO, 1990). Some of the records in the PMS database also contain information about asphalt layer thickness. Attempts were made to find a mathematical relationship between traffic volume and the asphalt layer thickness found in the PMS database and suggested by the Ontario's Pavement Design and Rehabilitation Manual. It was found that the asphalt thickness specifications may be represented by a logarithmic relationship with annual ESALs which can be found from traffic volume information.

This relationship is shown in Equation [4.1]. The R^2 associated with the equation is 0.99 which shows that the asphalt thicknesses estimated from the equation are reliable and the equation can estimate asphalt layer thicknesses quite well. It is also assumed that the minimum thickness for asphalt layer used in Ontario is 50 mm.

$$\text{Asphalt Thickness} = \max \begin{cases} 41.0 * \text{Ln}\left(\frac{\text{Initial Annual ESALs}}{10000}\right) \\ 50 \text{ mm} \end{cases} \quad [4.1]$$

$R^2 = 0.99$ $t = 52.4$

The procedure developed for approximating the base thickness is based on the historical information available in the PMS database. Reviewing the existing information implied that similar to the asphalt layer thickness design, base thicknesses are designed according to the traffic level of the roads. It was found that the base thicknesses could be categorized into three classes for three different traffic volumes as shown in Table 4.1. As may be seen from the table, the base thickness may be 150 mm of granular material for low and medium traffic volumes and 200 mm for high volume roads. However, an extra 100 mm of open granular drainage layer (OGDL) is usually used for high volume roads (more than 1,000,000 ESALs/year).

Table 4.1. Granular Base Thickness

Initial Annual ESALs	Granular Base Thickness
$0 < \text{ESALs} \leq 800,000$	150 mm
$800,000 < \text{ESALs} \leq 1,000,000$	200 mm
$1,000,000 < \text{ESALs}$	200 mm + 100 mm (OGDL layer)

The approximation of subbase thickness is a more sophisticated procedure and is based on optimization techniques. To estimate the missing subbase thickness information, an assumption has been made that pavements are designed optimally so that the total life-cycle cost of each road section is minimized. Based on this assumption, the life-cycle costs of several pavement sections with different traffic and subgrade conditions were carried out and the optimum subbase thickness of each pavement section was found. The observations of the estimated values for subbase thicknesses showed that statistically significant relationships exist between the optimum subbase thickness and subgrade types and ESALs associated with different pavement sections. The relationships are shown by equations [4.2] and [4.3] for Northern and Southern Ontario, respectively. The dependent variable, H_e , in Equations [4.2] and [4.3] represents the granular base equivalent thickness (GBE) of all pavement layers.

Northern Ontario:

$$\ln(H_e) = 4.49 + 0.14 \times (\text{ESALs})^{1/6} + 8.23 \times (M_s)^{-3/5} \quad [4.2]$$

$R^2 = 0.97$ $t_1 = 98.2$ $t_2 = 29.1$ $t_3 = 48.4$

Southern Ontario:

$$\ln(H_e) = 4.50 + 0.14 \times (\text{ESALs})^{1/6} + 8.33 \times (M_s)^{-3/5} \quad [4.3]$$

$R^2 = 0.98$ $t_1 = 80.7$ $t_2 = 26.4$ $t_3 = 41.2$

where,

- H_e = optimal pavement granular base equivalent thickness in mm,
 ESALs = initial annual ESALs, and
 M_s = subgrade modulus of elasticity, MPa.

The above equations are developed mainly to show a relationship between optimal pavement thickness, traffic and subgrade properties to be used in the cost analysis modules used in the computer programs. The major concern about the equations was the predictability of the models. A data table reflecting the optimal pavement thickness magnitudes (similar to Table 4.1) for different roads might be enough to accomplish this task, but it was decided to use the above prediction equations instead of using data tables. Using functions instead of searching throughout data table in each run of analysis is advantageous because of the increased speed in the program run-time.

The t-values associated with each parameter imply that the equations and parameters are all statistically significant at more than 99 percent level of confidence. Also, R^2 values are shown below each equation (0.97 and 0.98 for Northern and Southern Ontario, respectively) and they indicate that the results of equations are reliable and can be used for approximating the equivalent granular base thickness of different pavement sections. The subbase thickness may be found by subtracting the granular base equivalent thickness of asphalt and base layers from H_e . The layer equivalencies for Ontario pavements, as described before, are 2.00, 1.00 and 0.67 for asphalt, granular base and subbase material, respectively. However, the estimated numbers were checked against the guidelines in the Ontario's Pavement Design Manual and if they were significantly different, they were adjusted so that they would reflect the specifications used in practice.

Although the above functions are mainly developed to facilitate the estimation of the pavement costs, they are meaningful and compatible with the physical and economic behavior of the pavements. Equations 4.1 to 4.3 as well as Table 4.1 show that the optimal pavement layer thickness is a factor of traffic loading and strength of the materials.

4.3.3. Design ESALs

The equivalent standard axle load (ESAL) is used to calculate the effect of the traffic mix on pavement damage. Therefore, it is important to seek reliable models to

estimate the total ESAL loadings that each pavement section may experience during its life. Different procedures have been developed to estimate ESALs from the traffic conditions and vehicle composition for different pavements. The method used in this research is based on Equation [4.4] which estimates the total number of ESALs for the design-lane of a multi-lane highway (MTO, 1996).

$$\text{Total Annual Design Lane ESALs} = \sum_{i=1}^n (AADT \times DF \times T_i \times LDF \times TF_i \times \text{Days}) \quad [4.4]$$

where,

- i = truck type,
- n = number of Truck types,
- $AADT$ = current Average Annual Daily Traffic,
- DF = directional Factor,
- T_i = proportion of $AADT$ which belongs to truck class i ,
- LDF = lane Distribution Factor for trucks,
- TF_i = truck factor for truck class I , and
- Days = days per year of truck traffic.

The differences in ESALs associated with different truck types are reflected in the truck factor (TF_i) which is the average ESALs produced by truck type i .

For the purpose of ESAL estimations, the vehicles have been classified into four groups. Table 4.2 shows the vehicle groups and their percentage in the traffic stream for different roads. Also, table 4.3 shows the average ESALs created by different vehicle groups (MTO, 1996). In this research, it is assumed that traffic grows by 2 percent annually.

Table 4.2. Vehicle Classification for ESAL Estimation

Truck Type	Highway Class			
	Freeway	Arterial	Collector	Local
2 and 3 axle trucks	90%	45%	25%	90%
4 axle trucks	2%	5%	5%	2%
5 axle trucks	4%	35%	45%	5%
6 and more axles	4%	15%	25%	3%

Table 4.3. Average ESALs for different Vehicle Groups

Truck Type	Average ESALs
2 and 3 axle trucks	0.4
4 axle trucks	2.0
5 axle trucks	1.2
6 and more axles	5.1

The Lane Distribution Factor (*LDF*) reflects the distribution of trucks between lanes. In general, trucks tend to use the right lane more than the left lane. The lane distribution factor varies for different highways with different traffic levels and number of lanes. Obviously, in 2-lane highways, all trucks and vehicles share one lane ($LDF=1.00$) but it would decrease as the number of lanes increases. Table 4.4 shows the *LDFs* for different types of highways suggested by MTO.

Table 4.4. Lane Distribution Factor (LDF)

Number of Lanes	AADT<15,000	15,000<AADT≤40,000	40,000<AADT
2	1.00	1.00	1.00
4	0.85	0.75	0.75
6 or more	0.60	0.50	0.45

4.4. DISCUSSION OF THE RESULTS

4.4.1. Life-Cycle Costs of Different Pavements in Ontario

The present worth of life-cycle costs of the pavements in Northern and Southern Ontario were calculated for different traffic and subgrade conditions and are shown in Figures 4.2 to 4.11 along with the regression equations. The logarithmic functions indicate that the pavement costs increase with decreasing rate as the ESAL loadings increase. The sharp increase in life-cycle costs for ESALs of more than 40 million accumulated during the 30 years of pavement life is because of the extra costs of the open granular drainage layer which is used for major roads to provide higher pavement quality.

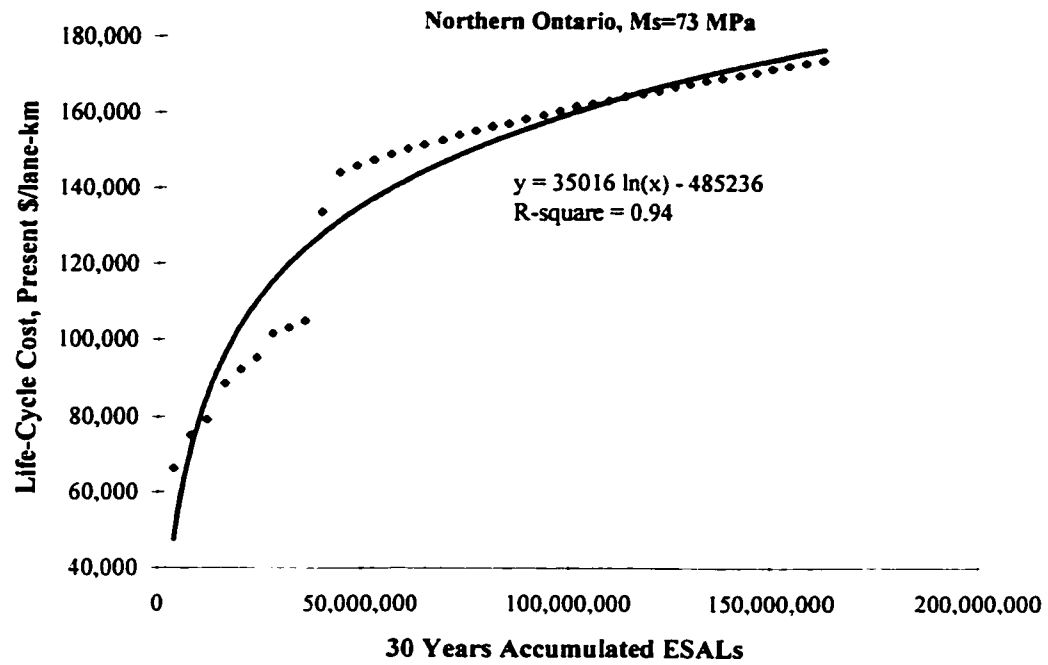

Figure 4.2. Pavement Life-Cycle Costs in Northern Ontario vs ESALs, Ms =73 MPa

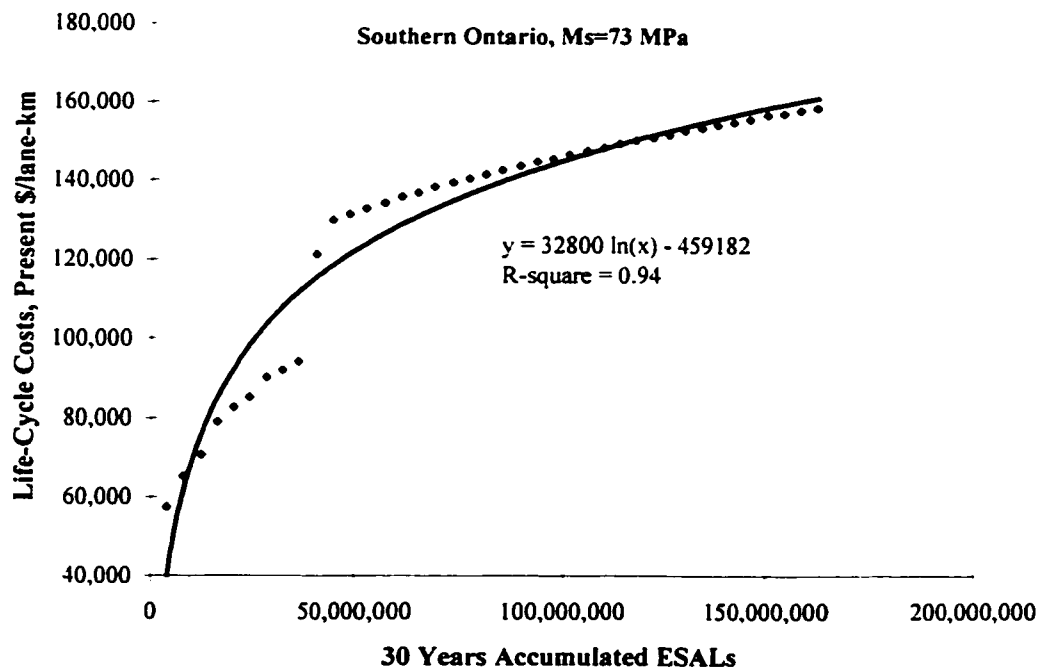

Figure 4.3. Pavement Life-Cycle Costs in Southern Ontario vs ESALs, Ms =73 MPa

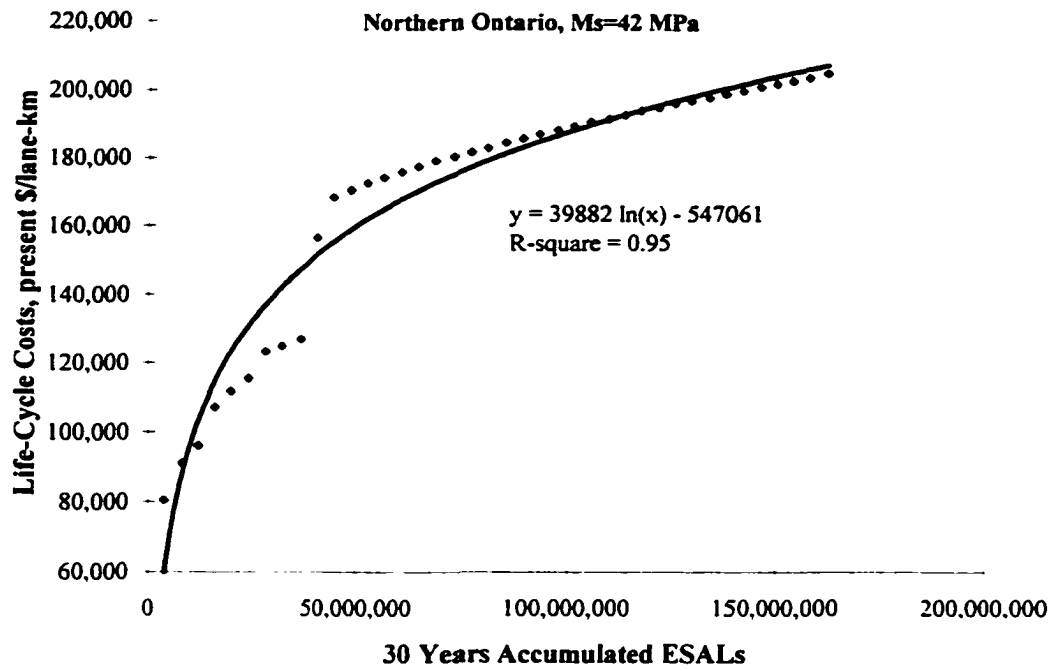

Figure 4.4. Pavement Life-Cycle Costs in Northern Ontario vs ESALs, Ms =42 MPa

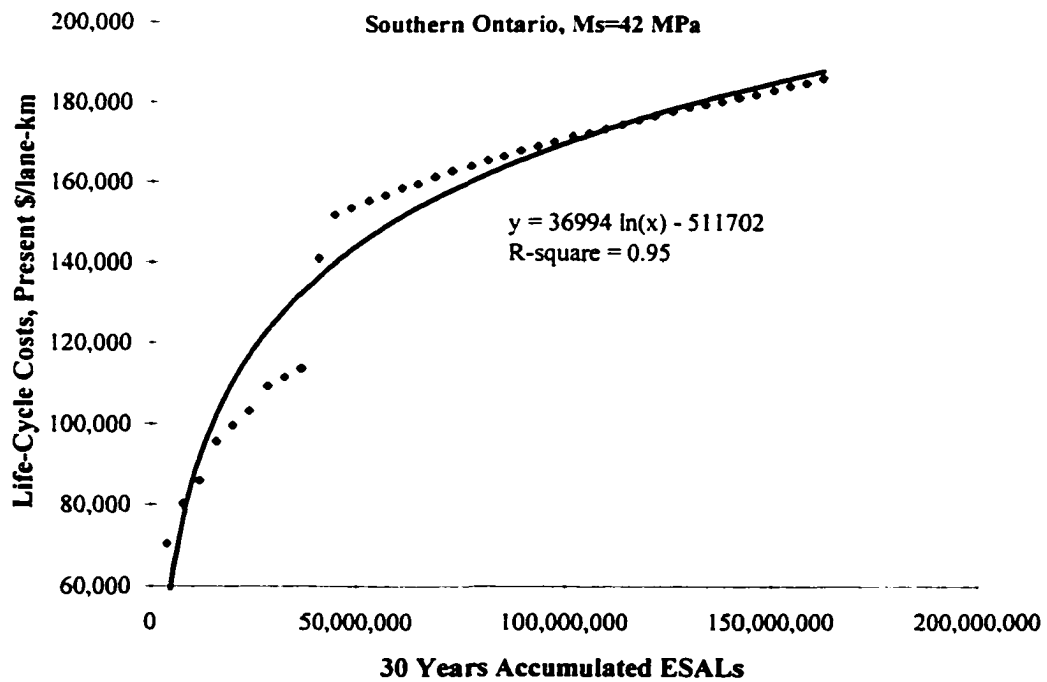

Figure 4.5. Pavement Life-Cycle Costs in Southern Ontario vs ESALs, Ms=42 MPa

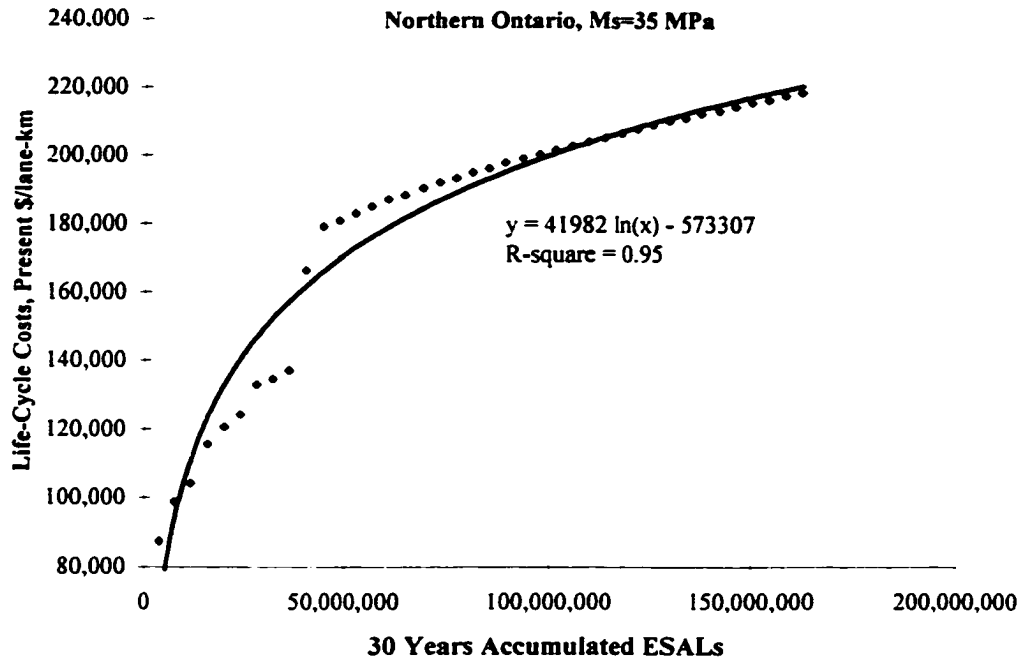

Figure 4.6. Pavement Life-Cycle Costs in Northern Ontario vs ESALs, Ms=35 MPa

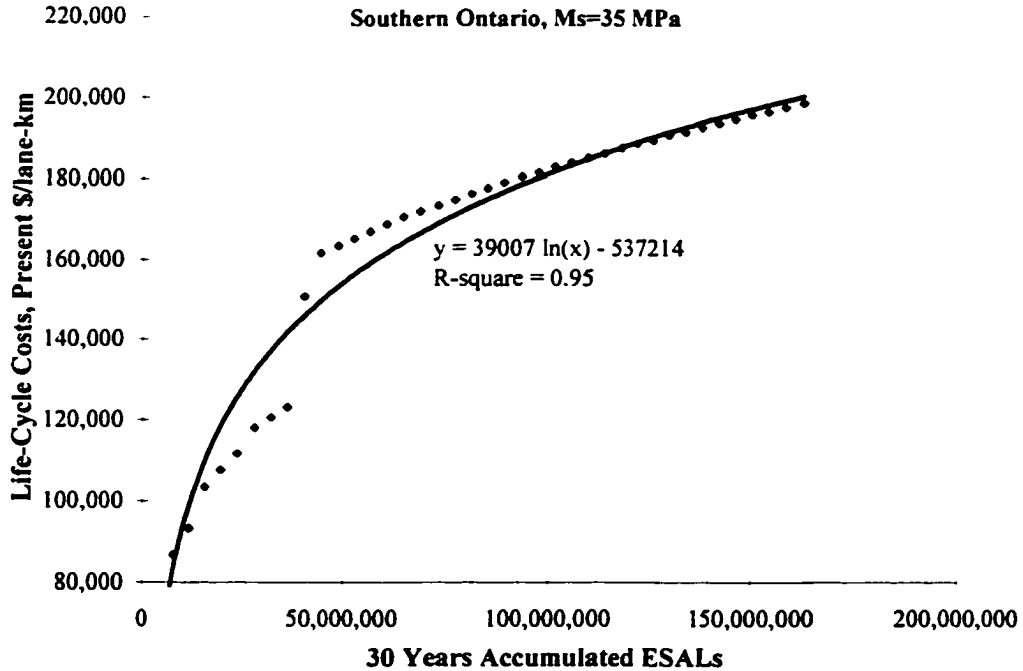

Figure 4.7. Pavement Life-Cycle Costs in Southern Ontario vs ESALs, Ms =35 MPa

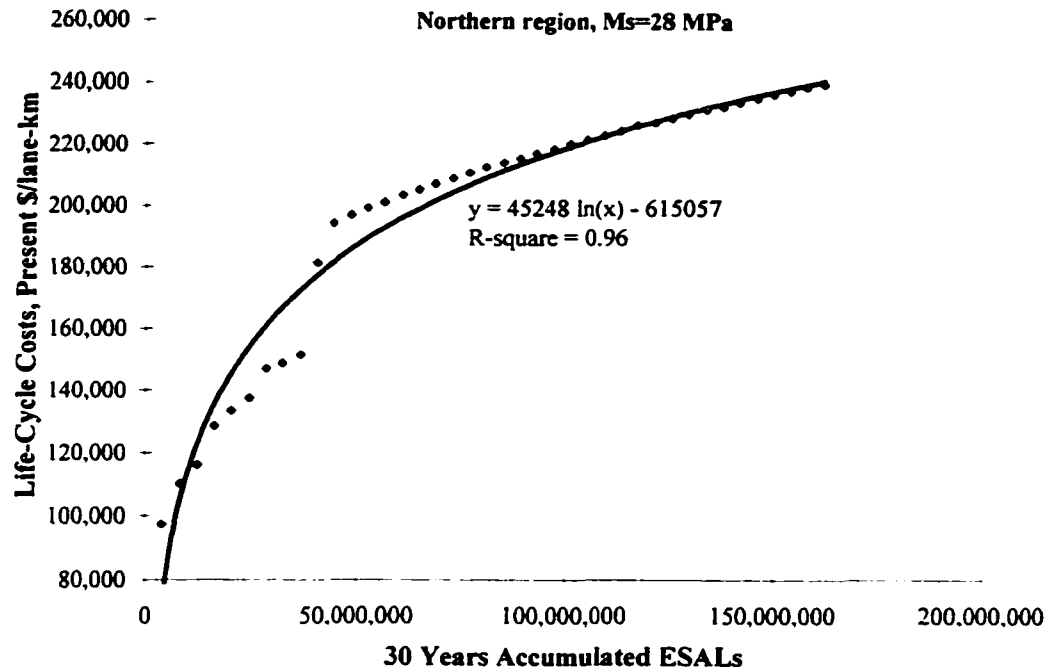

Figure 4.8. Pavement Life-Cycle Costs in Northern Ontario vs ESALs, Ms =28 MPa

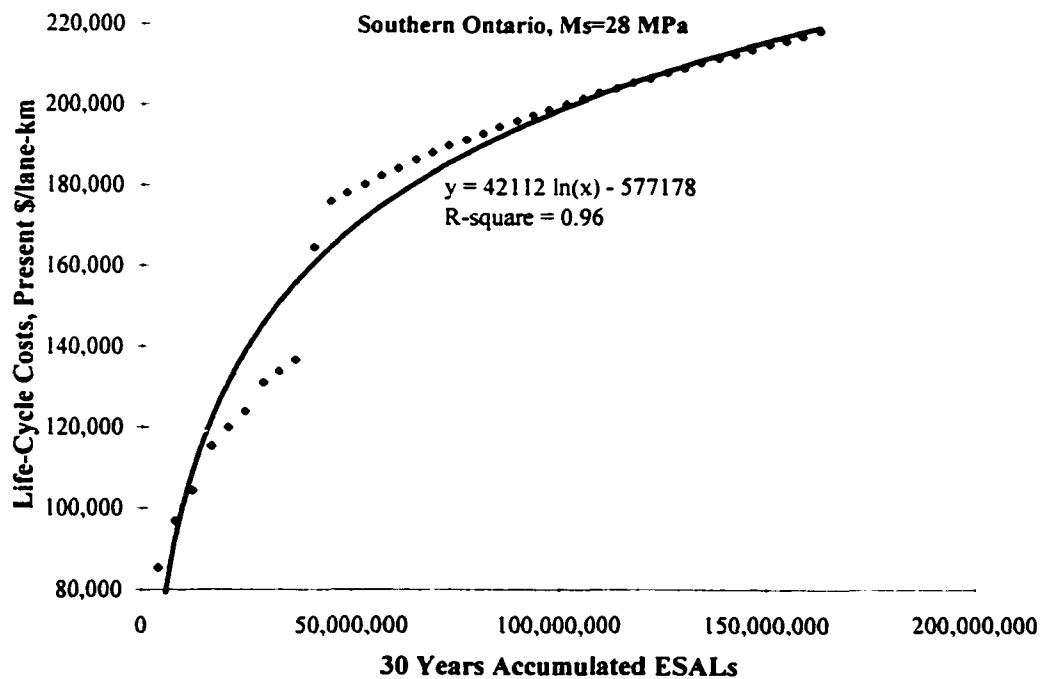

Figure 4.9. Pavement Life-Cycle Costs in Southern Ontario vs ESALs, Ms=28 MPa

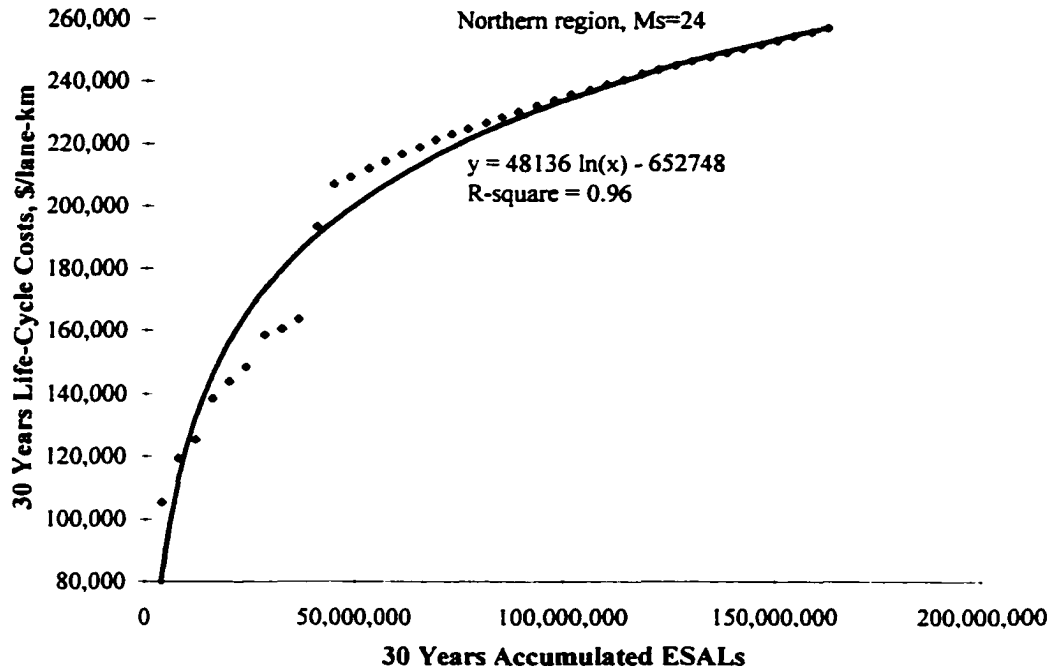

Figure 4.10. Pavement Life-Cycle Costs in Southern Ontario vs ESALs, Ms=24 MPa

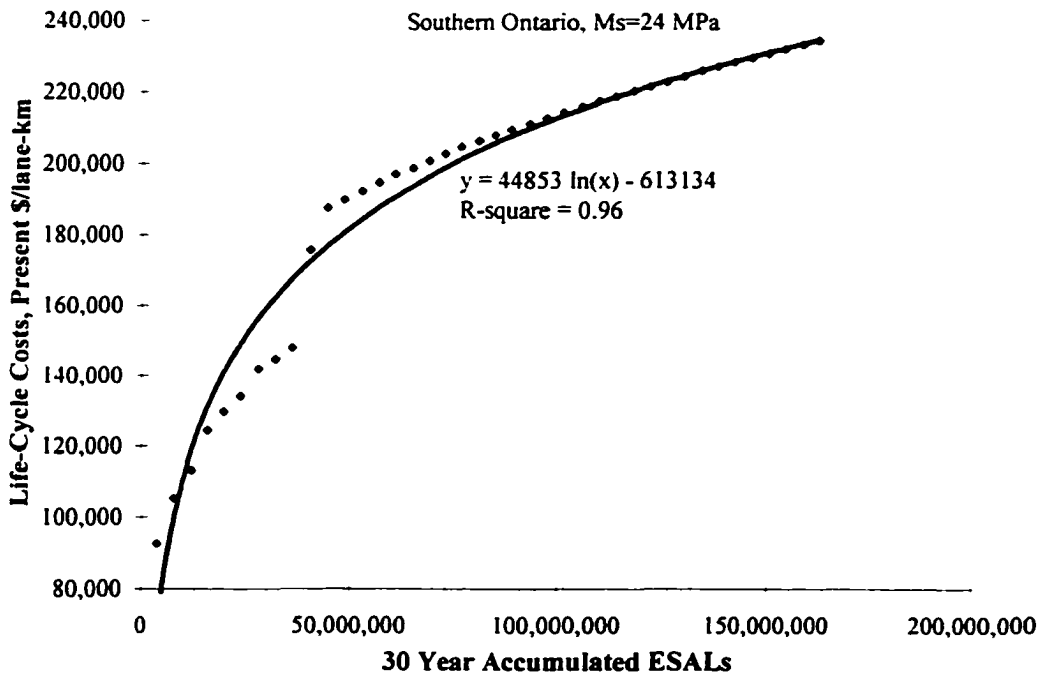

Figure 4.11. Pavement Life-Cycle Costs in Southern Ontario vs ESALs, Ms=24 MPa

In general, the figures imply that the life-cycle costs of pavements in Southern Ontario are lower than those in Northern Ontario, given the same traffic and subgrade conditions. As was explained in Chapter 3, the higher costs of pavements in Northern Ontario can be explained by faster rate of deterioration as a result of higher environmental degradation caused by harsher climate as well as higher material and labour costs compared to the pavement costs in Southern Ontario. The figures also imply that subgrade type, location (which represents environmental situation) and traffic conditions are all significant factors in pavement life-cycle costs.

The life-cycle costs of the pavements in Northern Ontario are roughly 10 percent higher than those of Southern Ontario. However, for low volume roads this difference may be up to 16 percent more in Northern Ontario. For example, Figures 4.5 and 4.6 show that for roads with accumulated ESALs of 40 million and subgrade M_s of 42 MPa, the 30 years life-cycle costs are about \$156,000/km-lane in Northern Ontario compared to \$141,000/km-lane in Southern Ontario (roughly 10 percent higher). Marginal costs may be estimated by taking the derivative of the life-cycle cost functions:

$$\text{Life Cycle Cost} = A \times \ln(\text{ESALs}) + B \quad [4.5]$$

which yields:

$$\text{Marginal Cost} = \frac{A}{\text{ESALs}} \quad [4.6]$$

The marginal cost functions are shown in Figures 4.12 and 4.13. The figures also show the decreasing trend of the pavement marginal costs as discussed before. In general, the pavement marginal costs per ESAL are roughly 7 percent higher for pavements in Northern Ontario than for those in Southern Ontario. For example, marginal costs imposed by an extra ESAL on pavement sections with $M_s = 42$ MPa and 40 million accumulated ESALs in Northern and Southern Ontario are \$0.01 /km and \$0.009 /km respectively. This reflects that the cost responsibility of a vehicle operating in Northern Ontario is higher than in Southern Ontario.

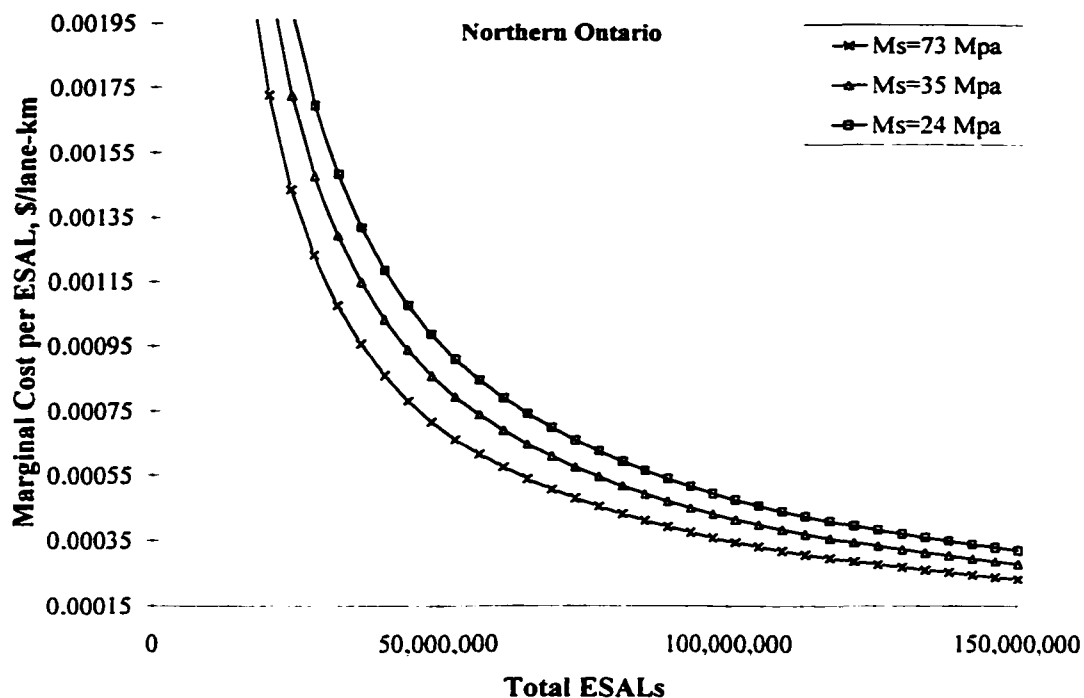

Figure 4.12. Pavement Marginal Costs vs ESALs, Northern Ontario

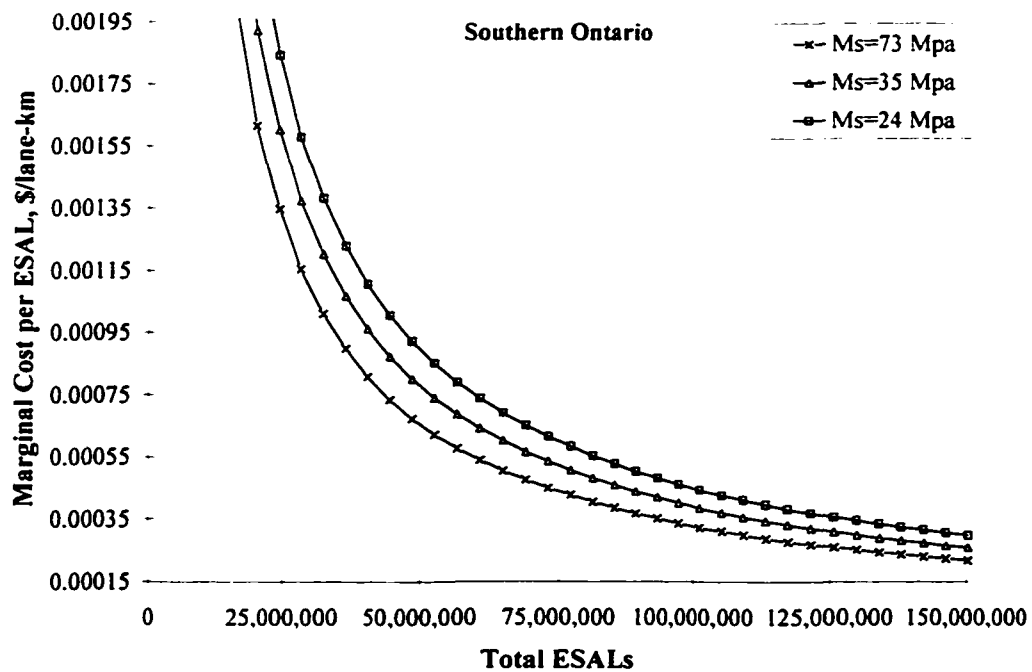

Figure 4.13. Pavement Marginal Costs vs ESALs, Southern Ontario

Table 4.5 shows the mean marginal pavement costs for different pavements on different subgrades and in different locations for a road with 1,000,000 accumulated ESALs in the initial year. As it may be observed from the entries of the table, the marginal costs of road use in Northern Ontario are more than the marginal costs of road use in Southern Ontario. Also, the weaker the pavement subgrade, the bigger the difference is between the marginal pavement costs in Northern and Southern Ontario.

Table 4.5. Pavement Marginal Costs for different Subgrade Types, Initial Year ESALs = 1 million, \$/km-ESAL

Subgrade Type	Location	
	Northern Ontario	Southern Ontario
Ms=73 MPa	0.00086	0.00081
Ms=42 MPa	0.00098	0.00091
Ms=35 MPa	0.0010	0.00096
Ms=28 MPa	0.0011	0.0010
Ms=24 MPa	0.0012	0.0011

In general, it may be concluded from the life-cycle and marginal cost analyses that all factors including subgrade type, traffic level and location of the pavement should be considered in the cost allocation analysis because they all have a significant influence on the total and marginal costs.

4.5. FREQUENCY DISTRIBUTION OF MARGINAL COSTS

The analysis of the effects of pavement and subgrade characteristics on construction and maintenance costs of pavements has shown that different pavement materials and thickness as well as subgrade types significantly affect pavement life-cycle costs. Therefore, to evaluate the cost responsibility of different road users, all of those factors should be taken into consideration.

The marginal costs for roads with a similar traffic level may be different because of the variety in truck configurations, number of lanes and subgrade types. In this regard, the cost analysis was accomplished based on the assumptions and marginal cost equations

discussed in the previous section. The analyses of pavement costs were carried out for each pavement section in the data base. The analyses yield a broad range of marginal and average costs per ESAL associated with different pavement sections.

Trial and error method was used to determine an appropriate road classification system. This required several analyses in which several arbitrary road classes (based on ESAL loading ranges) were examined and the frequency distribution of marginal costs for each road class was obtained. To arrive at a sound classification of roads, the frequency distributions of marginal costs within each classification scheme were compared with those of other schemes. Attempts were then made to find a road classification system which had the highest possible homogenous marginal cost frequency distribution within each class. This goal was achieved by comparing the variance of marginal costs for different classification systems.

The frequency distribution diagrams of the marginal costs of the suggested road classes are illustrated in Appendix B. The histograms in Appendix B illustrate the number of pavement sections found in each marginal cost range for different pavement sections with different traffic levels in Northern and Southern Ontario. The selected road classes are summarized and shown in Table 4.6. As it may be observed from the table, the roads are classified into 9 groups based on their levels of ESAL loadings. It must be mentioned that no road section with over 600,000 annual ESALs was found in the data base for Northern Ontario.

Table 4.6. Classifications of Roads

Class	Traffic Level	Region
1	Initial Year ESALs \leq 20,000	Northern Ontario
2	20,000 < Initial Year ESALs \leq 100,000	"
3	100,000 < Initial Year ESALs \leq 250,000	"
4	250,000 < Initial Year ESALs \leq 600,000	"
5	Initial Year ESALs \leq 20,000	Southern Ontario
6	20,000 < Initial Year ESALs \leq 100,000	"
7	100,000 < Initial Year ESALs \leq 250,000	"
8	250,000 < Initial Year ESALs \leq 600,000	"
9	600,000 < Initial Year ESALs	"

The mean marginal cost for each road class, as shown in Appendix B, is summarized in Table 4.7. As it may be seen from the table, the average marginal cost decreases for higher volume roads and are found to be lower for the pavements in Southern Ontario than those in Northern Ontario.

The classification of roads described in this chapter are used in the next chapters as inputs for the cost allocation analysis. The estimated marginal pavement costs associated with different road types are the major cost elements in the game-theoretic cost allocation model as described in the next chapter.

Table 4.7. Marginal Costs for different Road Classes

Road Class	Mean Marginal Cost, \$/ESAL-km
1	0.065
2	0.019
3	0.007
4	0.003
5	0.075
6	0.016
7	0.006
8	0.002
9	0.001

CHAPTER 5

Pavement Cost Allocation Analysis

5.1. INTRODUCTION

Different aspects of road investment and pricing issues as well as the advantages and disadvantages of road cost allocation procedures were explained in Chapter 2. The main objective of this chapter is to overcome the pitfalls of the existing cost allocation methods by developing a comprehensive cost allocation framework based on the concepts of cooperative game theory. The game theory method is successfully applied to the allocation of pavement costs for Ontario highway system and the results are described.

5.2. PROPOSED COST ALLOCATION METHOD

5.2.1. The Mathematical Framework of Cooperative Game Theory

A road network and its pricing system may be characterized as a game which consists of a set of players (road users) who have come to binding agreements on certain rules about how to use the system and how to pay for its costs. Game theory analyzes the

mathematical relationships between road usage and road prices and provide rational bases for formulating both efficiency and equity issues for the cost allocation analysis within an integrated framework (Garcia and Villareal, 1985; Heaney, 1979; Samet et al., 1982). The concepts of game theory are briefly explained in the following paragraphs.

A game is characterized by merely assigning a numerical value (e.g., cost responsibilities) to each possible coalition of n players (Mirman et al., 1985). An n -person game in a characteristic function form is a pair (N, c) , where $N = \{1, 2, \dots, n\}$ is a set of n players $1, 2, \dots, n$ and c is a real valued characteristic function on N . A real number $c(S)$ must be assigned to each subset S of N , where $c(\emptyset) = 0$ for the empty set \emptyset . The value of $c(S)$ may indicate the cost which the coalition S may cause when its members act together.

A set of n -dimensional payoff vectors called imputations represents all reasonable or realizable ways to split up the costs among the n participants. A vector $X = (X_1, X_2, \dots, X_n)$ with real components is an imputation for the game if X_i 's together can recover the total costs (for full cost recovery as an objective). This can be shown by:

$$X_1 + X_2 + \dots + X_n = c(N) \quad [5.1]$$

Various relationships and criteria may be introduced to reflect which set of the imputations are more preferred, more equitable, or more likely to result. Some of the rationales and criteria are as follows:

1. The analysis should not result in charging any user or a specific group of users with greater costs than would suffice for system development if they were alone in the system.
2. The members of each class S should at least pay their marginal cost.

These criteria may be expressed by:

$$\bullet \sum_N X_i = c(N) \quad (\text{Break-even rule}) \quad [5.2]$$

$$\bullet \sum_S X_i \leq c(S) \quad (\text{Stand-alone rule}) \quad [5.3]$$

$$\bullet \sum_S X_i \geq c(N) - c(N - S) \quad (\text{Marginal-cost test}) \quad [5.4]$$

These relations are in turn used to define a set of imputations which serves as a solution concept for the particular model. The core of the game is the set of all allocations X such that all of the above criteria hold for all $S \subseteq N$. However, further attempts must be made to find the optimal point from the core of the game (Mirman, 1985). The solution may be achieved by utilizing mathematical programming (MP), a framework for solving optimization problems. An MP framework consists of mathematical formulae including an objective function and several restrictions. The objective function of an MP reflects the goals of the analysis and the restrictions reflect the feasible solutions (Costa, 1990). The concepts of game theory can be used to establish a set of restrictions in the MP framework. The restrictions can be set in such a way that they reflect the technical and economic rationale of road pricing. The framework can yield a set of optimal road user fees by minimizing or maximizing an objective function. The formulation of the problem is described in the next section.

5.2.2. Application of Game Theory to Road Cost Allocation

In Chapter 2 the second-best pricing method (e.g., Ramsey pricing) was described as a solution for total cost recovery. The second-best pricing approach seeks to fulfill the gap between the average and marginal costs by setting user fees equal to marginal costs plus a secondary price in such a way that the total reduction in outputs (as a result of deviation from marginal costs) is minimized. This may be achieved by applying higher taxes to those who value the service more and have higher elasticity to price increases.

The major concept behind the proposed game-theoretic cost allocation method is similar to the idea of the second-best pricing. However, instead of using the inverse elasticity rule (as used in Ramsey pricing), the productive efficiencies of different users are used as a basis for distributing the costs between different road users. Also, some restrictions have been set to control the relationships between road user prices according to the productive efficiencies of different vehicles. For example, if there are two vehicles with the same marginal costs but different amounts of output, the prices should be set in such a way that the less productive vehicle pays more. This task, with the aid of other rationales and relationships between road prices, can be accomplished through mathematical programming within a single framework. Since pavement damage increases exponentially as a function of traffic loading, ideally it may be more desirable for a road agency to encourage vehicles to operate at lower weights (to minimize the pavement damage in inter-city road network), but not too low because damage to pavements as a result of truck tare-weight would not be economically justifiable for too small shipments.

The primary criteria and relationships between road prices used in the road cost allocation framework in this research are as follows:

1. The road users must at least pay their marginal costs.
2. The difference between average and marginal costs must be distributed among the users in the favour of the less damaging vehicles and against the more damaging ones (on the basis of *pavement-damage / payload* ratios).
3. Each class of vehicle must not be charged for the expenditures required for services necessary to accommodate other vehicles.
4. The pricing scheme should not conflict with the efficient utilization of road system; No vehicle should be charged equal to or less than other vehicles which generate greater output and cause less damage to the road system.







Before formulating the above relationships, road users were classified into different groups according to the configuration of their vehicles, the amount of load they

transport and the type of road they operate on. The classification is explained in the following subsection.

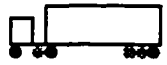
5.2.3. Classification of Road Users and Cost Allocation Matrix Cells

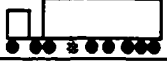
The vehicle classification was carried out according to the function, configuration and level of operation associated with different vehicles in the system. Vehicles have been classified in such a way that their physical configurations within a class are consistent and each class represents a relatively widely used vehicle type. The vehicle classes used in this research are shown in Table 5.1 along with the legal loads set by the Ministry of Transportation of Ontario. The allowable loads vary within and between different vehicle groups due to the variations in vehicle configurations. The means of allowable vehicle loads are shown in Table 5.1 for different vehicle types used in this research.

Table 5.1. Vehicle Classifications

Vehicle Class	Description	Vehicle Configuration	Mean Legal Loads
1	Automobiles		-
2	Tractor + Single, Tandem and Tridem Axle Semitrailers		GVW < 45 t
3	Tractor + 3 and 4 Axle Semitrailers		GVW < 50 t
4	Tractor + 5 and 6 Axle Semitrailers		GVW < 53 t
5	Heavy B-Trains and Heavy Haul and LTL A-Trains		GVW < 63 t
6	Tractor + 2 and 3 Axle A and B-Trains		GVW < 56 t
7	Single Unit Trucks		GVW < 25 t
8	Truck Trailers		GVW < 40 t

MTO has classified axle and vehicle legal loads for different truck types in a manual entitled Vehicle Dimensions and Weight Limits in Ontario (MTO, 1996). These limits are derived from the Ontario Bridge Formula as shown by Equation [5.5]. The equation defines the maximum gross weights of trucks and axle groups as a function of base length. The equivalent base length is defined as the length of a static equivalent uniformly distributed load which has the same impact on a bridge as an axle group or vehicle.

$$W_m = 9.80665 \times (10.0 + 3.0B_m - 0.0325B_m^2) \quad [5.5]$$

where,

W_m = the allowable total weight (kN) on a group of axles (e.g., an entire truck), and

B_m = the equivalent base length of the group of axles (m).

In this study each vehicle class is also subdivided into 5 groups according to the amount of payload carried. Payload ranges are shown by Table 5.2. There are 5 major payload ranges from zero (empty vehicles) to payloads over 50 t. The average load and geometric characteristics of vehicles in each class have been used for analyzing the cost implications of different vehicles.

Table 5.2. Load Classifications

Load Class	Payload (t)
1	0 - 1 (Empty)
2	1 - 10
3	10 - 30
4	30 - 50
5	> 50

Roads are also classified into 9 categories, as described in the previous chapter. Altogether, the system is classified into 8 vehicle groups, 5 payload ranges and 9 road

types. As described earlier, vehicles are classified based on their configurations, loads based on different ranges of payload, and roads according to their annual ESALs. This classification, therefore, represents 360 cells some of which are empty because there are no instances of such vehicles in the system.

5.2.4. Formulation of the Game-Theoretic Cost Allocation

Each user may be identified by an index ijk where i indicates the vehicle class, j indicates the load range and k indicates the road type. The charges are the decision variables and are denoted as:

$$T_{ijk} = \text{price/km for vehicle } i \text{ with load } j \text{ on road } k$$

There are some parameters that must be evaluated before establishing the MP framework. These parameters and their definitions are as follows:

P_{ijk} = the percentage of kilometres of total vehicle operation in the system for different classes of vehicles, loads, and roads.

MC_{ijk} = the marginal cost of vehicle i with load j for using each kilometre of road k .

$ESAL_{ijk}$ = Equivalent Single Axle Load of cell ijk .

Figure 5.1 shows the structure of the variables used in the MP framework. As the figure illustrates, the problem has been arranged in a 3-dimensional matrix in which rows indicate the vehicle type, columns show the load category and layers show the road type. Each cell of the matrix contains some information about each user. The information attributed to each cell include ESALs for the average vehicle weight and payload shown at top of each column, the marginal cost per kilometre of operation (MC_{ijk}), and the percentage of road use (P_{ijk}). This matrix will be called the cost allocation matrix throughout the rest of this thesis.

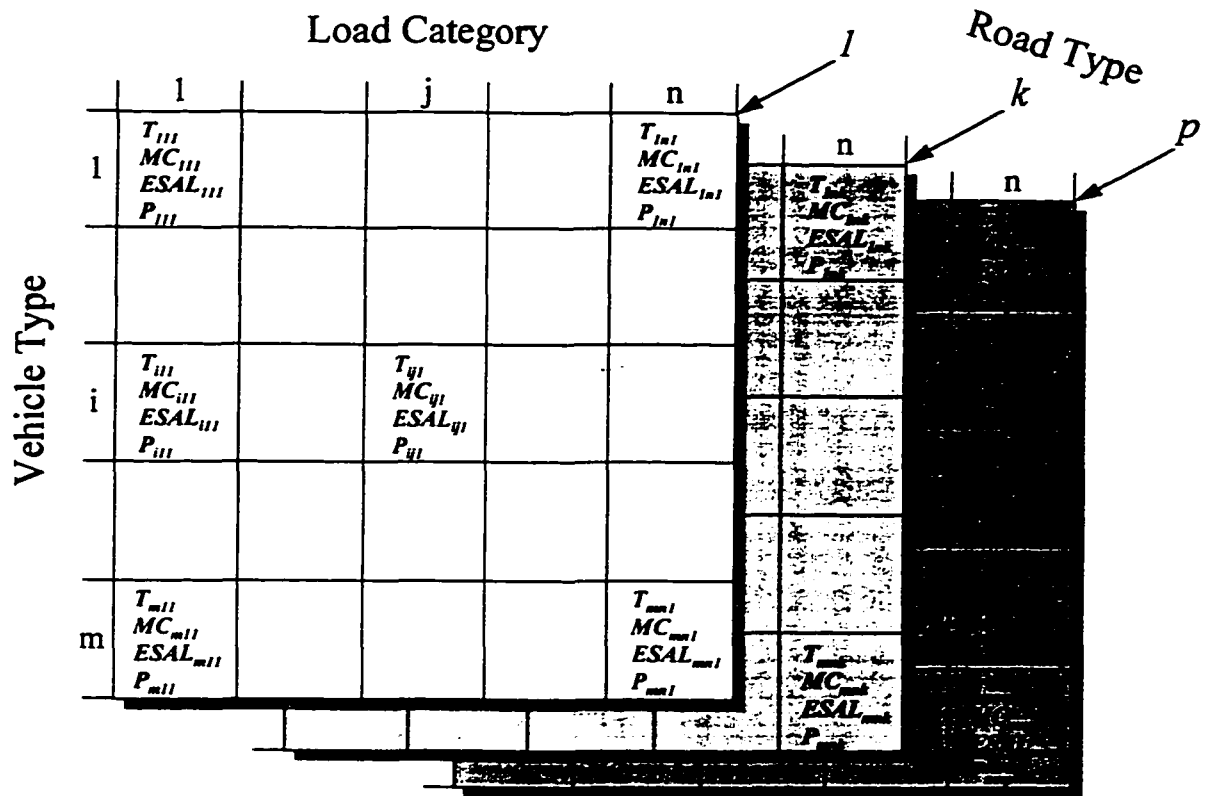

Figure 5.1. Matrix of Variables in Pavement Cost Allocator Submodule

Information in the cost allocation matrix is used to define the restrictions of the MP framework. The first set of restrictions ensures that each user would pay at least the marginal damage costs imposed on the system and can be shown by:

$$T_{ijk} \geq MC_{ijk} \quad \forall \quad i=1, 2, \dots, m \quad \& \quad j=1, 2, \dots, n \quad \& \quad k=1, 2, \dots, p \quad [5.6]$$

Another issue is efficiency, which may be measured by the ratio of the damage to benefit associated with each vehicle. For the purpose of this research, it is assumed that the benefits and damages of each vehicle may be estimated directly by the level of vehicle physical output and damage to the pavement, respectively. Based on this assumption, vehicle efficiency may be determined by the marginal pavement damage cost per unit of

output or payload ($MC_{ijk} / \text{Payload}_{ijk}$) which may represent vehicle efficiencies in terms of their productivity. This measure will be called the Inverse Efficiency Index throughout the rest of this research because the lower the Inverse Efficiency Index, the more efficient the vehicle in terms of its productivity. Some conditions have also been established to ensure that more efficient vehicles pay less than the others, as shown in the following:

$$\text{if } \frac{MC_{ijk}}{\text{Payload}_{ijk}} < \frac{MC_{i'j'k'}}{\text{Payload}_{i'j'k'}} \Rightarrow \frac{T_{ijk}}{\text{Payload}_{ijk}} < \frac{T_{i'j'k'}}{\text{Payload}_{i'j'k'}} \quad [5.7]$$

Based on the above definitions, it may not be possible to compare the efficiency of empty trucks with loaded trucks as the denominator of the Inverse Efficiency Index for an empty truck is reduced to zero (Payload = 0). To solve this problem, different vehicle classes are compared with each other and the efficiency measures have been calculated for the mean marginal cost per each unit of payload associated with each vehicle class based on Equation [5.8]:

$$\text{Avg Inverse Efficiency Index of Vehicle } (i), \text{ on road } (k) = \sum_{j=1.5} P_{ijk} \cdot \frac{MC_{ijk}}{\text{Payload}_{ijk}} \quad [5.8]$$

In the case of passenger cars, payload is not a relevant term and automobiles cannot be compared with trucks, because the economic value of passenger cars cannot be measured by the amount of commodity or payload they transport. To resolve this problem, the charges associated with passenger cars have been determined based on their share of usage of a basic road system designed for automobile loads. The basic system costs have been calculated when there are no trucks in the system and have been allocated to cars in proportion to their percentage of road use (in terms of kilometres) as compared to other vehicles. This is just a simplifying assumption and it would be advantageous to know the relative economic value of different vehicles including passenger cars and

trucks, compared to each other. This task is beyond the scope of this research but is recommended to be satisfied through further work.

If total cost recovery is sought, total charges must be equal to total pavement costs. The following condition ensures this goal:

$$\sum_{i,j,k} D \cdot P_{ijk} \cdot T_{ijk} = \text{Total Annual Pavement Costs} \quad [5.9]$$

where,

D = total annual distance driven by all vehicles.

One of the advantages of the proposed cost allocation method is that it is always possible to incorporate other conditions and to consider special circumstances by adding new restrictions. For example, some restrictions may be added in order to assign a minimum level of charges to specific vehicle classes based on the distance they travel. Such constraints may be represented by the following:

$$\frac{\sum_{j,k} T_{ijk}}{\sum_{i,j,k} T_{ijk}} \geq \alpha_i \cdot \sum_{j,k} P_{ijk} \quad \forall i \quad [5.10]$$

where, α_i is an arbitrary parameter reflecting exogenous judgments about the share of costs that are to be recovered from each vehicle class. This type of restriction may be determined in practice and used to address external circumstances such as air pollution, political concerns and admissibility of prices.

Other restrictions are also established to make sure that prices are set according to the efficiencies of different users. For example, considering two vehicles with equal output but different cost impacts on the system, the price allocated to the more damaging vehicle (less efficient vehicle) should be at least greater than the difference between the marginal costs of two vehicles, otherwise the operation of the less efficient vehicle is not

justified. This is based on the rationale that if a load can be carried at a lower cost it should either be taken that way or the extra cost imposed to the system should be paid. This means that lower charges should be assigned to less damaging vehicles. This is one of the advantages of the proposed cost allocation method that can incorporate many of the rational relationships between road user fees.

Due to different physical and geometrical characteristics of vehicle types, various vehicles have different optimal payloads which generate the lowest damage per unit of payload. For example, a small straight truck may be more economical for transporting light payloads, while a truck trailer with a larger number of axles may be more economical for carrying heavier ones. In this regard, some restrictions have been established to consider the pavement costs per unit of payload associated with different vehicles. The restrictions seek to ensure that the charges per unit payload are set according to cost implications of per unit payload carried by different vehicle types.

The above conditions determine the solution core (feasible solution region). To find the optimal point in that region, an objective function must be set. An ideal objective would be to maximize the output of the system while minimizing the damage to the infrastructure by regulating the road prices in such a way that the use of inefficient vehicles are discouraged by applying higher taxes. In general, as the price associated with a cell increases, demand and consequently quantity of output for that cell will decrease. This objective can be achieved if only the quantity of output for the service at price T_{ijk} could be estimated. Assuming that this relationship was known, the optimal set of prices can be found by the following:

$$\text{Minimize } \sum_{i,j,k} F(T_{ijk}) \cdot \frac{MC_{ijk}}{\text{Payload}_{ijk}} \quad [5.11]$$

where, $F(T_{ijk})$ = output of cell ijk at price T_{ijk} .

However, a large amount of information would be required to find the quantity of output at different road prices and neither such information nor reliable models for $F(T_{ijk})$ s were available at the time of the analysis. Also, it was found that T_{ijk} could be a

small figure compared to the total operating cost of trucks implying that changes in road prices could have limited influence on the demand for road services. Therefore, the objective function for the MP framework has been developed based on other rationales.

The ideal objective function described above could be interpreted as a function which minimizes the total damage imposed by vehicle operations on the system while at the same time keeping the total level of output constant. This objective results in low prices for the most efficient vehicles and high prices for the most damaging ones. This goal may be achieved by increasing the charges, as much as possible, for non-economical or less efficient vehicles. This can be done by minimizing the difference between the charges and the marginal costs associated with different vehicles and giving more weight in the minimization function to the less damaging ones. The weights in the objective function may be substituted with the ratio of payload to marginal cost of pavements ($\text{Payload}_{ijk} / MC_{ijk}$). This corresponds to vehicle efficiency. This can be formulated by the following function:

$$\text{Minimize } \sum_{i=2..8} \sum_{j=2..5} \sum_{k=1..9} \frac{\text{Payload}_{ijk}}{MC_{ijk}} \cdot (T_{ijk} - MC_{ijk}) \quad [5.12]$$

The above function minimizes the sum of the differences between the price and the marginal costs while giving more weight to the more efficient vehicles. The empty trucks and passenger cars whose efficiencies are not meaningful in terms of infrastructure damage have been excluded from the minimization function. Once the objective function and conditions are set, the optimal charges associated with each cell may be calculated by solving the MP using an optimization software (LINGO software is used to solve the MP framework in this research). The allocated charges will be later aggregated to an appropriate level for use in the charging structure module. The detailed results obtained from the optimization procedure will be useful in measuring the level of inefficiency and equity loss as a result of simplification and aggregation of theoretical charges.

In addition to the integrity that the proposed method could offer, the method is flexible and transparent. Different restrictions and objective functions can be examined in the MP framework and any changes in the prices or attributes associated with different entities of the system can be clearly observed. These characteristics will help to better understand the effects of different parameters and objectives on the results of cost allocation analysis. The rational allocation of road costs requires establishment of relationships between road prices. Mathematical programming can handle relationships and restrictions within the solution framework and this makes the method suitable for the cost allocation analysis.

5.3. COST ALLOCATION MATRIX

5.3.1. Cell Entries

The cost allocation matrix provides a skeleton for a cost allocation analysis. Different layers, one for each road class, of the cost allocation matrix are shown in Tables 5.3 to 5.11. The number of ESALs associated with each cell have been calculated based on the axle loads found in the truck inventory database and ESAL equations explained in the previous chapters. The marginal costs associated with each cell have been estimated based on the results of the marginal costs per ESAL achieved through the system-wide pavement cost analyses (also described in the previous chapter). The percentage of system usage associated with each cell has been calculated from the MTO's pavement and truck inventory databases.

Each cell shows the marginal costs, number of ESALs and the percentage of usage of the road system in Ontario. As can be observed from the cost allocation matrix, the marginal costs increase significantly as payloads increase. For each payload class different vehicle types have different marginal cost implications. There is always one vehicle type which incurs the minimum cost for each payload range. For example, vehicle Type 8 (truck trailers) would be the most efficient vehicle class to transport light payloads of up to 10 tonnes, while vehicle Type 5 and 6 (A and B-Trains) would be the most efficient vehicle classes for transporting heavy loads.

Table 5.3. Cost Allocation Matrix, Road Class 1

Vehicle Class		Payload				
		Empty	1-10 t	10-30 t	30-50 t	>50 t
Passenger Cars	MC, \$/km	0.0000015				
	ESAL	0.0001				
	P	0.0049				
Tractor + Single, Tandem and Tridem Semitrailers	MC, \$/km	0.040	0.052	0.15	0.48	
	ESAL	0.62	0.80	2.26	7.44	
	P	0.000080	0.000074	0.00011	0.000012	
Tractor + 3 and 4 Axle Semitrailers	MC, \$/km	0.049	0.072	0.22	0.70	1.32
	ESAL	0.75	1.11	3.42	10.76	20.34
	P	0.0000059	0.0000053	0.000014	0.0000092	0.0000045
Tractor + 5+ Axle Semitrailers	MC, \$/km	0.053	0.069	0.16	0.45	0.86
	ESAL	0.81	1.07	2.51	7.02	13.32
	P	0.0000011	0.0000014	0.0000076	0.0000020	0.00000080
Tractor + Heavy Haul A and B-Trains	MC, \$/km	0.042	0.059	0.16	0.40	0.70
	ESAL	0.65	0.92	2.42	6.14	10.76
	P	0.0000019	0.0000058	0.0000015	0.0000028	0.0000047
Tractor + 2 and 3 Axle B-Trains	MC, \$/km	0.044	0.061	0.15	0.41	0.73
	ESAL	0.69	0.94	2.34	6.32	11.19
	P	0.0000056	0.0000076	0.0000056	0.000018	0.0000015
Single Unit Trucks	MC, \$/km	0.0072	0.042	0.58		
	ESAL	0.11	0.65	8.98		
	P	0.000062	0.000032	0.000068		
Truck Trailers	MC, \$/km	0.0075	0.017	0.15	0.69	1.40
	ESAL	0.12	0.26	2.24	10.67	21.54
	P	0.0000029	0.0000015	0.0000021	0.0000017	0.0000010

Road Class 1:

Northern Ontario

0 < Annual ESALs ≤ 20,000

Table 5.4. Cost Allocation Matrix, Road Class 2

Vehicle Class		Payload				
		Empty	1-10 t	10-30 t	30-50 t	>50 t
Passenger Cars	MC, \$/km	0.0000019				
	ESAL	0.0001				
	P	0.036				
Tractor + Single, Tandem and Tridem Semitrailers	MC, \$/km	0.012	0.015	0.043	0.14	
	ESAL	0.62	0.80	2.26	7.44	
	P	0.0010	0.00094	0.0014	0.00015	
Tractor + 3 and 4 Axle Semitrailers	MC, \$/km	0.014	0.021	0.065	0.21	0.39
	ESAL	0.75	1.11	3.42	10.76	20.34
	P	0.000074	0.000068	0.00018	0.00012	0.000057
Tractor + 5+ Axle Semitrailers	MC, \$/km	0.016	0.020	0.048	0.13	0.25
	ESAL	0.81	1.07	2.51	7.02	13.32
	P	0.000014	0.0000018	0.0000097	0.000026	0.000010
Tractor + Heavy Haul A and B-Trains	MC, \$/km	0.012	0.017	0.046	0.12	0.21
	ESAL	0.65	0.92	2.42	6.14	10.76
	P	0.000024	0.0000074	0.000019	0.000036	0.000059
Tractor + 2 and 3 Axle B-Trains	MC, \$/km	0.013	0.018	0.045	0.12	0.22
	ESAL	0.69	0.94	2.34	6.32	11.19
	P	0.000071	0.0000097	0.000071	0.00023	0.000019
Single Unit Trucks	MC, \$/km	0.0021	0.012	0.17		
	ESAL	0.11	0.65	8.98		
	P	0.00078	0.00041	0.000087		
Truck Trailers	MC, \$/km	0.0022	0.0049	0.043	0.20	0.41
	ESAL	0.12	0.26	2.24	10.67	21.54
	P	0.000037	0.000019	0.000026	0.000022	0.000013

Road Class 2:

Northern Ontario

20,000 < Annual ESALs ≤ 100,000

Table 5.5. Cost Allocation Matrix, Road Class 3

Vehicle Class		Payload				
		Empty	1-10 t	10-30 t	30-50 t	>50 t
Passenger Cars	MC, \$/km	0.0000067				
	ESAL	0.0001				
	P	0.050				
Tractor + Single, Tandem and Tridem Semitrailers	MC, \$/km	0.0042	0.0054	0.015	0.050	
	ESAL	0.62	0.80	2.26	7.44	
	P	0.0017	0.0015	0.0024	0.00025	
Tractor + 3 and 4 Axle Semitrailers	MC, \$/km	0.0051	0.0075	0.023	0.073	0.14
	ESAL	0.75	1.11	3.42	10.76	20.34
	P	0.00012	0.00011	0.00029	0.00019	0.000094
Tractor + 5+ Axle Semitrailers	MC, \$/km	0.0055	0.0072	0.017	0.047	0.090
	ESAL	0.81	1.07	2.51	7.02	13.32
	P	0.000023	0.000003	0.000016	0.000042	0.000017
Tractor + Heavy Haul A and B-Trains	MC, \$/km	0.0044	0.0062	0.016	0.041	0.073
	ESAL	0.65	0.92	2.42	6.14	10.76
	P	0.000040	0.0000122	0.000031	0.000059	0.000098
Tractor + 2 and 3 Axle B-Trains	MC, \$/km	0.0046	0.0063	0.016	0.043	0.075
	ESAL	0.69	0.94	2.34	6.32	11.19
	P	0.00012	0.000016	0.00012	0.00038	0.000032
Single Unit Trucks	MC, \$/km	0.00075	0.0044	0.061		
	ESAL	0.11	0.65	8.98		
	P	0.0013	0.00068	0.00014		
Truck Trailers	MC, \$/km	0.00077	0.0017	0.015	0.072	0.15
	ESAL	0.12	0.26	2.24	10.67	21.54
	P	0.000061	0.000032	0.000043	0.000036	0.000021

Road Class 3:

Northern Ontario

100,000 < Annual ESALs ≤ 250,000

Table 5.6. Cost Allocation Matrix, Road Class 4

Vehicle Class		Payload				
		Empty	1-10 t	10-30 t	30-50 t	>50 t
Passenger Cars	MC, \$/km	0.0000031				
	ESAL	0.0001				
	P	0.013				
Tractor + Single, Tandem and Tridem Semitrailers	MC, \$/km	0.0019	0.0024	0.0069	0.023	
	ESAL	0.62	0.80	2.26	7.44	
	P	0.00039	0.00036	0.00055	0.00058	
Tractor + 3 and 4 Axle Semitrailers	MC, \$/km	0.0023	0.0034	0.010	0.033	0.066
	ESAL	0.75	1.11	3.42	10.76	20.34
	P	0.000029	0.000026	0.000069	0.000045	0.000022
Tractor + 5+ Axle Semitrailers	MC, \$/km	0.0025	0.0033	0.0077	0.021	0.041
	ESAL	0.81	1.07	2.51	7.02	13.32
	P	0.000053	0.0000069	0.000037	0.0000099	0.0000039
Tractor + Heavy Haul A and B-Trains	MC, \$/km	0.0020	0.0028	0.007	0.019	0.033
	ESAL	0.65	0.92	2.42	6.14	10.76
	P	0.0000094	0.0000028	0.0000074	0.000014	0.0000023
Tractor + 2 and 3 Axle B-Trains	MC, \$/km	0.0021	0.0029	0.0072	0.019	0.034
	ESAL	0.69	0.94	2.34	6.32	11.19
	P	0.000027	0.0000037	0.000027	0.000088	0.0000075
Single Unit Trucks	MC, \$/km	0.00034	0.0020	0.027		
	ESAL	0.11	0.65	8.98		
	P	0.00030	0.00016	0.000033		
Truck Trailers	MC, \$/km	0.00035	0.00079	0.0069	0.033	0.066
	ESAL	0.12	0.26	2.24	10.67	21.54
	P	0.000014	0.0000074	0.000010	0.0000084	0.0000049

Road Class 4:

Northern Ontario

250,000 < Annual ESALs ≤ 600,000

Table 5.7. Cost Allocation Matrix, Road Class 5

Vehicle Class		Payload				
		Empty	1-10 t	10-30 t	30-50 t	>50 t
Passenger Cars	MC, \$/km	0.000075				
	ESAL	0.0001				
	P	0.0092				
Tractor + Single, Tandem and Tridem Semitrailers	MC, \$/km	0.046	0.059	0.17	0.56	
	ESAL	0.62	0.80	2.26	7.44	
	P	0.00013	0.00012	0.00018	0.000019	
Tractor + 3 and 4 Axle Semitrailers	MC, \$/km	0.056	0.083	0.26	0.80	1.52
	ESAL	0.75	1.11	3.42	10.76	20.34
	P	0.0000095	0.0000086	0.000023	0.000015	0.00000073
Tractor + 5+ Axle Semitrailers	MC, \$/km	0.061	0.080	0.19	0.52	0.99
	ESAL	0.81	1.07	2.51	7.02	13.32
	P	0.0000018	0.0000023	0.0000012	0.0000033	0.00000013
Tractor + Heavy Haul A and B-Trains	MC, \$/km	0.049	0.068	0.18	0.46	0.80
	ESAL	0.65	0.92	2.42	6.14	10.76
	P	0.0000031	0.00000094	0.0000024	0.0000046	0.00000075
Tractor + 2 and 3 Axle B-Trains	MC, \$/km	0.051	0.070	0.17	0.47	0.83
	ESAL	0.69	0.94	2.34	6.32	11.19
	P	0.0000090	0.0000012	0.0000090	0.000029	0.0000025
Single Unit Trucks	MC, \$/km	0.0083	0.049	0.67		
	ESAL	0.11	0.65	8.98		
	P	0.000099	0.000052	0.000011		
Truck Trailers	MC, \$/km	0.0086	0.019	0.17	0.80	1.61
	ESAL	0.12	0.26	2.24	10.67	21.54
	P	0.0000047	0.0000024	0.0000033	0.0000028	0.00000016

Road Class 5:

Southern Ontario

0 < Annual ESALs ≤ 20,000

Table 5.8. Cost Allocation Matrix, Road Class 6

Vehicle Class		Payload				
		Empty	1-10 t	10-30 t	30-50 t	>50 t
Passenger Cars	MC, \$/km	0.0000016				
	ESAL	0.0001				
	P	0.0762				
Tractor + Single, Tandem and Tridem Semitrailers	MC, \$/km	0.010	0.013	0.036	0.12	
	ESAL	0.62	0.80	2.26	7.44	
	P	0.0011	0.0010	0.0016	0.00017	
Tractor + 3 and 4 Axle Semitrailers	MC, \$/km	0.012	0.018	0.055	0.17	0.33
	ESAL	0.75	1.11	3.42	10.76	20.34
	P	0.000083	0.000076	0.00020	0.00013	0.000064
Tractor + 5+ Axle Semitrailers	MC, \$/km	0.013	0.017	0.040	0.11	0.21
	ESAL	0.81	1.07	2.51	7.02	13.32
	P	0.000016	0.0000020	0.000011	0.000029	0.0000011
Tractor + Heavy Haul A and B-Trains	MC, \$/km	0.010	0.015	0.039	0.10	0.17
	ESAL	0.65	0.92	2.42	6.14	10.76
	P	0.0000274	0.0000083	0.0000214	0.0000402	0.00000664
Tractor + 2 and 3 Axle B-Trains	MC, \$/km	0.011	0.015	0.038	0.10	0.18
	ESAL	0.69	0.94	2.34	6.32	11.19
	P	0.000079	0.000011	0.000079	0.00026	0.000022
Single Unit Trucks	MC, \$/km	0.0018	0.010	0.14		
	ESAL	0.11	0.65	8.98		
	P	0.00088	0.00046	0.000097		
Truck Trailers	MC, \$/km	0.0018	0.0041	0.036	0.17	0.35
	ESAL	0.12	0.26	2.24	10.67	21.54
	P	0.000042	0.000022	0.000029	0.000024	0.0000014

Road Class 6:

Southern Ontario

20,000 < Annual ESALs ≤ 100,000

Table 5.9. Cost Allocation Matrix, Road Class 7

Vehicle Class		Payload				
		Empty	1-10 t	10-30 t	30-50 t	>50 t
Passenger Cars	MC, \$/km	0.0000060				
	ESAL	0.0001				
	P	0.16				
Tractor + Single, Tandem and Tridem Semitrailers	MC, \$/km	0.0037	0.0048	0.014	0.045	
	ESAL	0.62	0.80	2.26	7.44	
	P	0.0032	0.0029	0.0045	0.00047	
Tractor + 3 and 4 Axle Semitrailers	MC, \$/km	0.0045	0.0067	0.021	0.065	0.12
	ESAL	0.75	1.11	3.42	10.76	20.34
	P	0.00023	0.00021	0.00056	0.00037	0.000018
Tractor + 5+ Axle Semitrailers	MC, \$/km	0.0049	0.0064	0.015	0.042	0.080
	ESAL	0.81	1.07	2.51	7.02	13.32
	P	0.000043	0.000056	0.000030	0.000080	0.000032
Tractor + Heavy Haul A and B-Trains	MC, \$/km	0.0039	0.0055	0.015	0.037	0.065
	ESAL	0.65	0.92	2.42	6.14	10.76
	P	0.000076	0.000023	0.000060	0.00011	0.000018
Tractor + 2 and 3 Axle B-Trains	MC, \$/km	0.0041	0.0057	0.014	0.038	0.067
	ESAL	0.69	0.94	2.34	6.32	11.19
	P	0.00022	0.000030	0.00022	0.00071	0.000060
Single Unit Trucks	MC, \$/km	0.00067	0.0039	0.054		
	ESAL	0.11	0.65	8.98		
	P	0.0024	0.0013	0.00027		
Truck Trailers	MC, \$/km	0.00069	0.0016	0.013	0.064	0.13
	ESAL	0.12	0.26	2.24	10.67	21.54
	P	0.00012	0.000060	0.000081	0.000068	0.000040

Road Class 7:

Southern Ontario

100,000 < Annual ESALs ≤ 250,000

Table 5.10. Cost Allocation Matrix, Road Class 8

Vehicle Class		Payload				
		Empty	1-10 t	10-30 t	30-50 t	>50 t
Passenger Cars	MC, \$/km	0.0000029				
	ESAL	0.0001				
	P	0.16				
Tractor + Single, Tandem and Tridem Semitrailers	MC, \$/km	0.0018	0.0023	0.0067	0.022	
	ESAL	0.62	0.80	2.26	7.44	
	P	0.0048	0.0044	0.0068	0.00070	
Tractor + 3 and 4 Axle Semitrailers	MC, \$/km	0.0022	0.0033	0.010	0.032	0.060
	ESAL	0.75	1.11	3.42	10.76	20.34
	P	0.00035	0.00032	0.00084	0.00055	0.000027
Tractor + 5+ Axle Semitrailers	MC, \$/km	0.0024	0.0032	0.0074	0.021	0.039
	ESAL	0.81	1.07	2.51	7.02	13.32
	P	0.000065	0.0000084	0.000046	0.00012	0.0000048
Tractor + Heavy Haul A and B-Trains	MC, \$/km	0.0019	0.0027	0.0071	0.018	0.032
	ESAL	0.65	0.92	2.42	6.14	10.76
	P	0.00012	0.000035	0.000090	0.00017	0.000028
Tractor + 2 and 3 Axle B-Trains	MC, \$/km	0.0020	0.0028	0.0069	0.019	0.033
	ESAL	0.69	0.94	2.34	6.32	11.19
	P	0.00033	0.000046	0.00033	0.0011	0.000091
Single Unit Trucks	MC, \$/km	0.00033	0.0019	0.026		
	ESAL	0.11	0.65	8.98		
	P	0.0037	0.0019	0.00041		
Truck Trailers	MC, \$/km	0.00034	0.00076	0.0066	0.031	0.063
	ESAL	0.12	0.26	2.24	10.67	21.54
	P	0.00018	0.000091	0.00012	0.00010	0.000060

Road Class 8:

Southern Ontario

250,000 < Annual ESALs ≤ 600,000

Table 5.11. Cost Allocation Matrix, Road Class 9

Vehicle Class		Payload				
		Empty	1-10 t	10-30 t	30-50 t	>50 t
Passenger Cars	MC, \$/km	0.00000015				
	ESAL	0.0001				
	P	0.36				
Tractor + Single, Tandem and Tridem Semitrailers	MC, \$/km	0.00092	0.0012	0.0034	0.011	
	ESAL	0.62	0.80	2.26	7.44	
	P	0.011	0.0098	0.015	0.0016	
Tractor + 3 and 4 Axle Semitrailers	MC, \$/km	0.0011	0.0017	0.0051	0.016	0.030
	ESAL	0.75	1.11	3.42	10.76	20.34
	P	0.00078	0.00071	0.0019	0.0012	0.000060
Tractor + 5+ Axle Semitrailers	MC, \$/km	0.0012	0.0016	0.0037	0.010	0.020
	ESAL	0.81	1.07	2.51	7.02	13.32
	P	0.00014	0.000019	0.00010	0.00027	0.000011
Tractor + Heavy Haul A and B-Trains	MC, \$/km	0.0010	0.0014	0.0036	0.0091	0.016
	ESAL	0.65	0.92	2.42	6.14	10.76
	P	0.00012	0.000077	0.00020	0.00037	0.000062
Tractor + 2 and 3 Axle B-Trains	MC, \$/km	0.0010	0.0014	0.0035	0.0094	0.017
	ESAL	0.69	0.94	2.34	6.32	11.19
	P	0.00074	0.00010	0.00074	0.0024	0.00020
Single Unit Trucks	MC, \$/km	0.00017	0.0010	0.013		
	ESAL	0.11	0.65	8.98		
	P	0.0082	0.0043	0.00091		
Truck Trailers	MC, \$/km	0.00017	0.00038	0.0033	0.016	0.032
	ESAL	0.12	0.26	2.24	10.67	21.54
	P	0.00039	0.00020	0.00027	0.00023	0.000013

Road Class 9:

Southern Ontario

600,000 < Annual ESALs

Some of the loads in the tables are illegal but have been observed in the system according to the information available in the truck inventory database. These loads cause extensive damage to the pavements and under the current pricing regime in Ontario trucks are penalized for transporting such loads (more than the legal limits). For example, the legal load for typical semitrailers in Ontario is about 45 t to 50 t that reflects a payload of about 35 t. However, as can be seen from the tables many semitrailers operate at illegal loads. This situation occurs because of lack of enforcement and because sometimes penalties associated with over limit loads are economically justifiable for truck users. The appropriate charges for the legal and illegal load situations will be discussed in the next section.

5.3.2. General Characteristics of the Users

Table 5.12 shows some of the general cost characteristics of different roads in Ontario. The second column of the table shows the percentage distance driven by automobiles operating on different road types. The third column represents the total pavement costs and the fourth column shows the cost of the basic pavement system if automobiles were the only vehicles in the system. These costs have been estimated using computer programs developed to carry out the system-wide pavement cost analysis as described in Chapter 4. The last column of the table shows the ratio of the cost of the basic pavement system to the total costs of the existing system.

Table 5.12. Cost Characteristics of Different Roads

	Road Class	% Distance by Autos	Total Costs \$	Basic Road Costs, \$	Basic/Total %
Northern Ontario	1	91	83,822,000	66,388,000	79.2
	2	86	436,929,000	308,977,000	70.7
	3	84	330,824,000	191,572,000	57.9
	4	85	50,901,000	27,196,000	53.4
Southern Ontario	5	92	71,274,000	52,171,000	73.2
	6	92	359,120,000	237,031,000	66.0
	7	90	562,691,000	309,914,000	55.1
	8	85	380,415,000	193,656,000	50.9
	9	85	459,593,000	202,319,000	44.0

As shown by Table 5.12, the passenger cars account for most of the vehicle operation in terms of kilometres travelled. It can also be observed from the table that the percentage of operation of passenger cars vary for different roads. These figures indicate that passenger cars are responsible for the greater part of the basic system (about 45 percent to about 80 percent of the total cost of the existing system). Table 5.12 also indicates that the cost of the basic pavement system in Northern Ontario is relatively higher than in Southern Ontario. This is due to the higher environmental degradation in the north relative to the south. For example, the ratios of basic to total pavement life-cycle costs are, respectively, 79 and 73 percent for low volume roads in Northern and Southern Ontario.

When comparing the basic pavement costs with the existing total pavement costs it can be observed that the ratio of basic to total costs are lower for higher volume roads. For pavements in Southern Ontario the ratio of basic to total pavement cost is 73 percent for low volume roads. This ratio is as low as 44 percent for high volume roads in the same region. This trend is due to the exponentially increasing effect of pavement thickness on pavement strength, which provides the pavements with much higher fatigue capacity.

Figure 5.2 illustrates the marginal costs versus payload for different truck types. As can be seen from the figure, the marginal costs increase exponentially as payloads increase. In some instances there is only a small difference in marginal costs of different vehicles for a specific payload. For some payloads, however, the choice of an appropriate vehicle seems to be a critical issue. For example, single unit trucks (vehicle type 7) incur greater damage for payloads greater than 10 tonnes as compared to the other vehicles. B-Trains (vehicle types 5 and 6) seem to be the most efficient vehicle classes for transporting heavy loads. The pavement marginal cost associated with B-Trains at 55 t payload is about \$0.05/km. The pavement marginal cost for the other vehicles is as high as \$0.11/km.

The efficiency of each vehicle group is an important issue that must be considered in the cost allocation analysis. The objective of efficient cost allocation is to assign prices

to different vehicles in such a way that the users will be encouraged to use efficient vehicles for different load ranges or pay the difference between the actual cost effects of their vehicle and the most efficient vehicle.

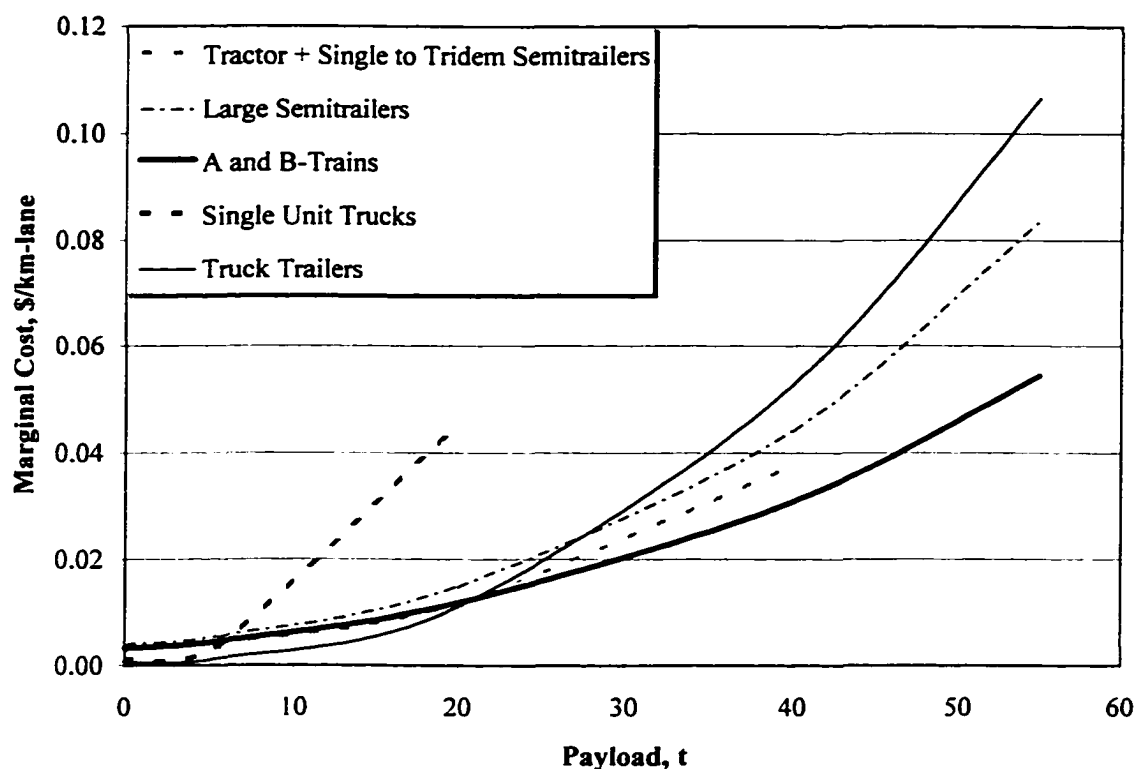

Figure 5.2. ESALs versus Payloads for Different Truck Types

Figure 5.3 illustrates the marginal costs associated with different vehicles for different payload groups. The optimal vehicle for each payload range can be identified from the figure. As the load increases the cost implications of the truck type becomes more important. It can be observed from the figure that damage imposed by single unit trucks (Vehicle Type 7) increases sharply for loads over 10 t. Also, B-Trains appear to be the most economic vehicles to carry medium and heavy payloads in the ranges of 30-50 t

and greater than 50 t. Truck trailers, however, appear to be the most economical vehicle for light payloads.

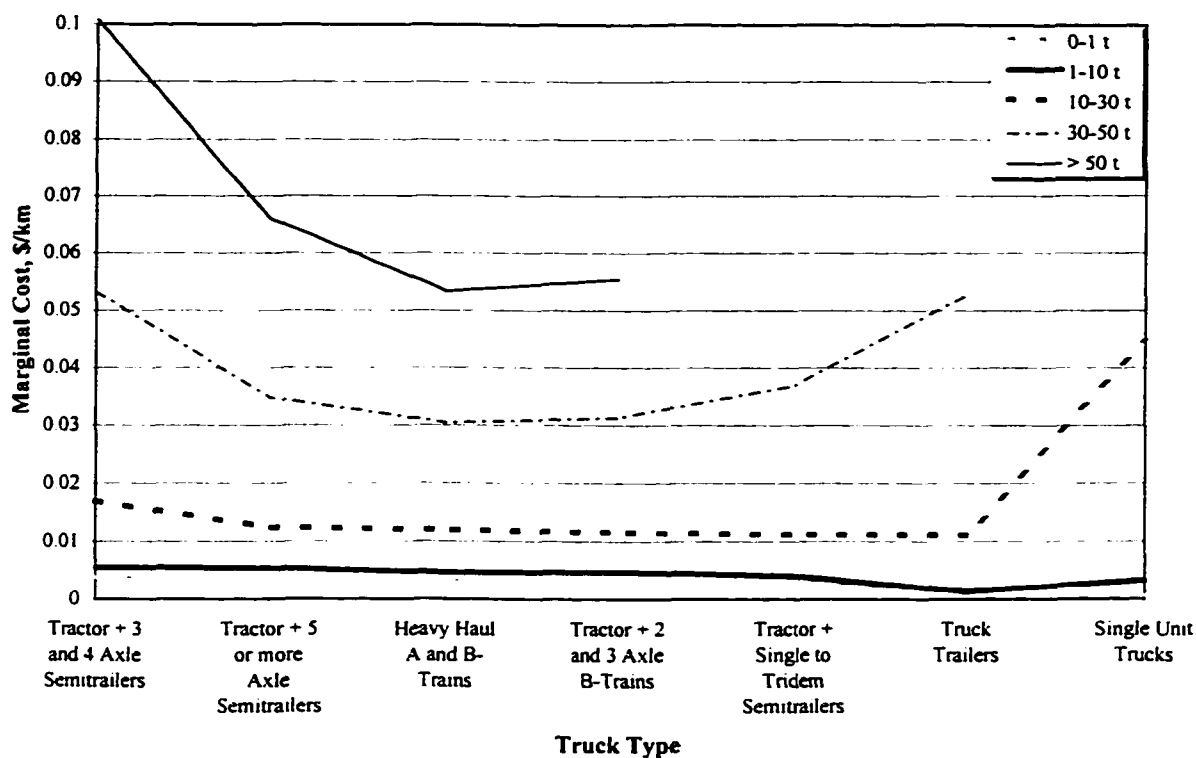

Figure 5.3. Marginal Costs versus Truck Types for Different Load Ranges

Figure 5.4 illustrates the general structure of the mathematical programming framework based on the criteria and rationales described earlier. The real mathematical programming framework used for the cost allocation analysis consisted of one linear objective function and 800 restrictions. The code for the framework was generated by computer macros that took the data from the cost allocation matrix and arranged the relationships between prices. The output and implications of the analysis are described in the next section. The source file of the linear programming framework is provided in Appendix C.

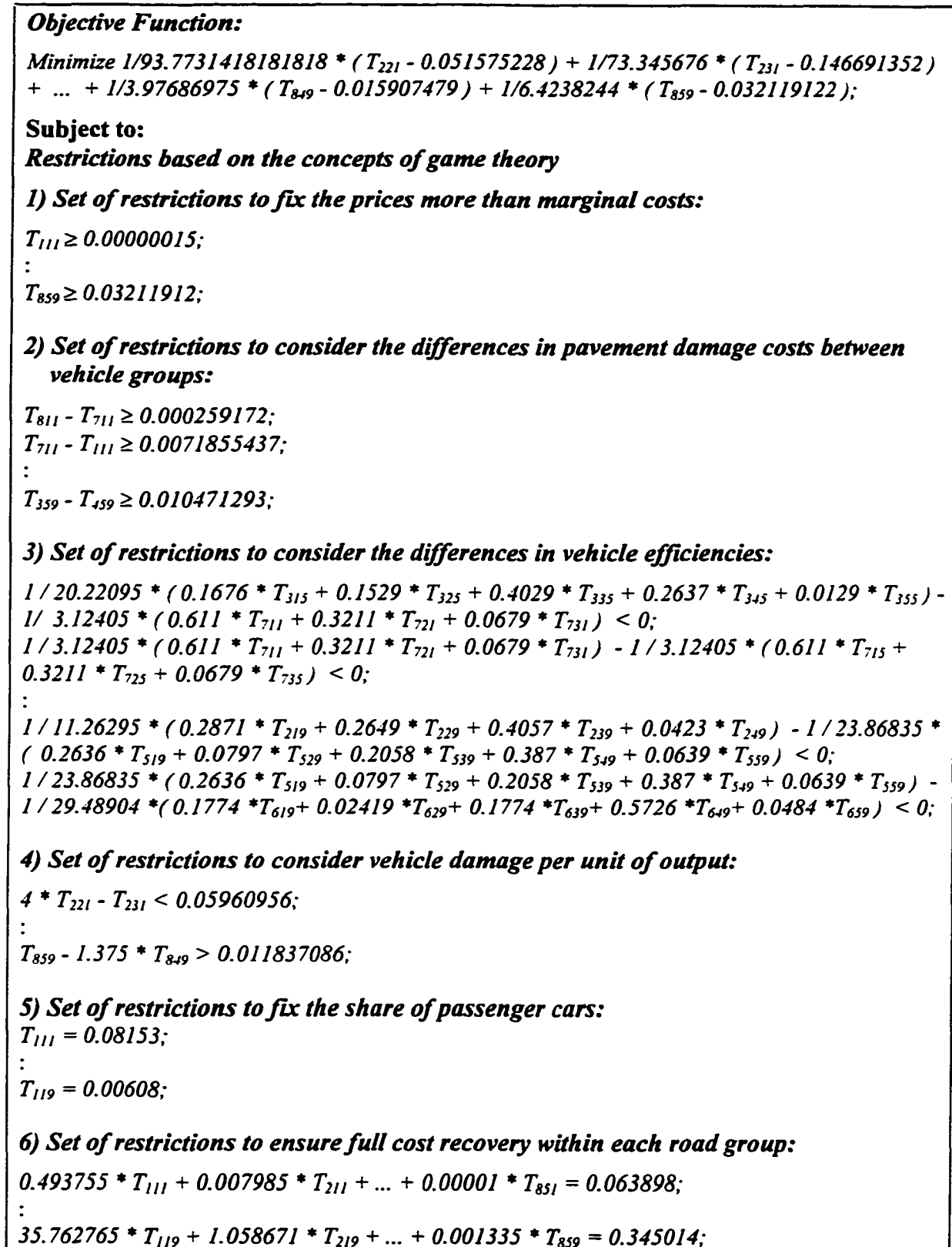

Figure 5.4. Summarized Structure of Cost Allocation Framework

5.4. COST ALLOCATION RESULTS

Tables 5.13 to 5.21 show the results of the game-theoretic cost allocation analysis. As shown by the tables, the analysis has produced different road prices associated with different cells. It may be impractical to have such a complex charging system, but the results at such a detailed level may give a better understanding of the mechanisms behind the costs imposed by users. This may lead to a better arrangement and evaluation of practical road user charges. Some guidelines are provided in Chapter 8 on how to use the results of the cost allocation analysis for establishing an efficient and feasible charging system in Ontario.

Table 5.13. Pavement User Charges for Road Class 1, \$/km

Vehicle Class		Payload				
		Empty	1-10 t	10-30 t	30-50 t	>50 t
Passenger Cars	MC	0.00000015				
	Price	0.069				
Tractor + Single, Tandem and Tridem Semitrailers	MC	0.040	0.052	0.15	0.48	
	Price	0.57	0.052	0.15	0.68	
Tractor + 3 and 4 Axle Semitrailers	MC	0.049	0.072	0.22	0.70	1.32
	Price	1.533	0.072	0.22	2.20	3.45
Tractor + 5 or more Axle Semitrailers	MC	0.053	0.069	0.16	0.45	0.86
	Price	1.54	0.069	0.16	0.65	1.18
Tractor + Heavy Haul A and B-Trains	MC	0.042	0.059	0.16	0.40	0.70
	Price	1.24	0.059	0.16	0.40	0.74
Tractor + 2 and 3 Axle B-Trains	MC	0.044	0.061	0.15	0.41	0.73
	Price	1.53	0.061	0.15	0.61	1.04
Single Unit Trucks	MC	0.0072	0.042	0.58		
	Price	0.54	0.042	3.32		
Truck Trailers	MC	0.0075	0.017	0.15	0.69	1.40
	Price	0.54	0.017	0.15	2.19	3.53

Table 5.14. Pavement User Charges for Road Class 2, \$/km

Vehicle Class		Payload				
		Empty	1-10 t	10-30 t	30-50 t	>50 t
Passenger Cars	MC	0.0000065				
	Price	0.050				
Tractor + Single, Tandem and Tridem Semitrailers	MC	0.012	0.015	0.043	0.14	
	Price	0.41	0.015	0.043	0.32	
Tractor + 3 and 4 Axle Semitrailers	MC	0.014	0.021	0.065	0.21	0.39
	Price	1.13	0.021	0.065	0.58	0.93
Tractor + 5 or more Axle Semitrailers	MC	0.016	0.020	0.048	0.13	0.25
	Price	1.13	0.020	0.048	0.31	0.51
Tractor + Heavy Haul A and B-Trains	MC	0.012	0.017	0.046	0.12	0.21
	Price	0.96	0.017	0.046	0.12	0.22
Tractor + 2 and 3 Axle B-Trains	MC	0.013	0.018	0.045	0.12	0.22
	Price	1.13	0.018	0.045	0.29	0.47
Single Unit Trucks	MC	0.0021	0.012	0.17		
	Price	0.10	0.012	0.17		
Truck Trailers	MC	0.0022	0.0049	0.043	0.20	0.41
	Price	0.40	0.0049	0.043	0.57	0.95

Table 5.15. Pavement User Charges for Road Class 3, \$/km

Vehicle Class		Payload				
		Empty	1-10 t	10-30 t	30-50 t	>50 t
Passenger Cars	MC	0.0000067				
	Price	0.027				
Tractor + Single, Tandem and Tridem Semitrailers	MC	0.0042	0.0054	0.015	0.050	
	Price	0.19	0.0054	0.015	0.22	
Tractor + 3 and 4 Axle Semitrailers	MC	0.0051	0.0075	0.023	0.073	0.14
	Price	0.39	0.0075	0.085	0.27	0.41
Tractor + 5 or more Axle Semitrailers	MC	0.0055	0.0072	0.017	0.047	0.090
	Price	0.39	0.0072	0.017	0.21	0.32
Tractor + Heavy Haul A and B-Trains	MC	0.0044	0.0062	0.016	0.041	0.073
	Price	0.38	0.0062	0.016	0.09	0.15
Tractor + 2 and 3 Axle B-Trains	MC	0.0046	0.0063	0.016	0.043	0.075
	Price	0.38	0.0063	0.016	0.20	0.30
Single Unit Trucks	MC	0.00075	0.0044	0.061		
	Price	0.03	0.0044	0.12		
Truck Trailers	MC	0.00077	0.0017	0.015	0.072	0.15
	Price	0.19	0.0017	0.015	0.26	0.42

Table 5.16. Pavement User Charges for Road Class 4, \$/km

Vehicle Class		Payload				
		Empty	1-10 t	10-30 t	30-50 t	>50 t
Passenger Cars	MC	0.0000031				
	Price	0.016				
Tractor + Single, Tandem and Tridem Semitrailers	MC	0.0019	0.0024	0.0069	0.023	
	Price	0.033	0.0024	0.077	0.16	
Tractor + 3 and 4 Axle Semitrailers	MC	0.0023	0.0034	0.010	0.033	0.066
	Price	0.034	0.0034	0.085	0.24	0.35
Tractor + 5 or more Axle Semitrailers	MC	0.0025	0.0033	0.0077	0.021	0.041
	Price	0.034	0.0033	0.078	0.16	0.33
Tractor + Heavy Haul A and B-Trains	MC	0.0020	0.0028	0.007	0.019	0.033
	Price	0.033	0.0028	0.078	0.16	0.25
Tractor + 2 and 3 Axle B-Trains	MC	0.0021	0.0029	0.0072	0.019	0.034
	Price	0.033	0.0029	0.077	0.16	0.32
Single Unit Trucks	MC	0.00034	0.0020	0.027		
	Price	0.019	0.0020	0.10		
Truck Trailers	MC	0.00035	0.00079	0.0069	0.033	0.066
	Price	0.032	0.00079	0.0069	0.24	0.35

Table 5.17. Pavement User for Charges for Road Class 5, \$/km

Vehicle Class		Payload				
		Empty	1-10 t	10-30 t	30-50 t	>50 t
Passenger Cars	MC	0.0000075				
	Price	0.0076				
Tractor + Single, Tandem and Tridem Semitrailers	MC	0.046	0.059	0.17	0.56	
	Price	0.87	0.059	0.17	0.56	
Tractor + 3 and 4 Axle Semitrailers	MC	0.056	0.083	0.26	0.80	1.52
	Price	1.33	0.083	0.26	1.71	2.84
Tractor + 5 or more Axle Semitrailers	MC	0.061	0.080	0.19	0.52	0.99
	Price	1.33	0.080	0.19	0.52	1.05
Tractor + Heavy Haul A and B-Trains	MC	0.049	0.068	0.18	0.46	0.80
	Price	1.13	0.068	0.18	0.46	0.85
Tractor + 2 and 3 Axle B-Trains	MC	0.051	0.070	0.17	0.47	0.83
	Price	1.32	0.070	0.17	0.47	0.89
Single Unit Trucks	MC	0.0083	0.049	0.67		
	Price	0.83	0.049	0.67		
Truck Trailers	MC	0.0086	0.019	0.17	0.80	1.61
	Price	0.83	0.019	0.17	1.70	2.93

Table 5.18. Pavement User Charges for Road Class 6, S/km

Vehicle Class		Payload				
		Empty	1-10 t	10-30 t	30-50 t	>50 t
Passenger Cars	MC	0.0000065				
	Price	0.019				
Tractor + Single, Tandem and Tridem Semitrailers	MC	0.010	0.013	0.036	0.12	
	Price	0.26	0.013	0.036	0.13	
Tractor + 3 and 4 Axle Semitrailers	MC	0.012	0.018	0.055	0.17	0.33
	Price	0.99	0.018	0.20	0.47	0.75
Tractor + 5 or more Axle Semitrailers	MC	0.013	0.017	0.040	0.11	0.21
	Price	0.99	0.017	0.040	0.12	0.24
Tractor + Heavy Haul A and B-Trains	MC	0.010	0.015	0.039	0.10	0.17
	Price	0.56	0.015	0.039	0.10	0.18
Tractor + 2 and 3 Axle B-Trains	MC	0.011	0.015	0.038	0.10	0.18
	Price	0.99	0.015	0.038	0.11	0.20
Single Unit Trucks	MC	0.0018	0.010	0.14		
	Price	0.08	0.010	0.29		
Truck Trailers	MC	0.0018	0.0041	0.036	0.17	0.35
	Price	0.25	0.004	0.036	0.46	0.77

Table 5.19. Pavement User for Charges for Road Class 7, S/km

Vehicle Class		Payload				
		Empty	1-10 t	10-30 t	30-50 t	>50 t
Passenger Cars	MC	0.0000060				
	Price	0.014				
Tractor + Single, Tandem and Tridem Semitrailers	MC	0.0037	0.0048	0.014	0.045	
	Price	0.15	0.0048	0.014	0.25	
Tractor + 3 and 4 Axle Semitrailers	MC	0.0045	0.0067	0.021	0.065	0.12
	Price	0.15	0.0067	0.14	0.33	0.49
Tractor + 5 or more Axle Semitrailers	MC	0.0049	0.0064	0.015	0.042	0.080
	Price	0.15	0.0064	0.015	0.24	0.36
Tractor + Heavy Haul A and B-Trains	MC	0.0039	0.0055	0.015	0.037	0.065
	Price	0.15	0.0055	0.015	0.22	0.32
Tractor + 2 and 3 Axle B-Trains	MC	0.0041	0.0057	0.014	0.038	0.067
	Price	0.15	0.0057	0.014	0.24	0.35
Single Unit Trucks	MC	0.00067	0.0039	0.054		
	Price	0.023	0.0039	0.17		
Truck Trailers	MC	0.00069	0.0016	0.013	0.064	0.13
	Price	0.15	0.0016	0.013	0.33	0.50

Table 5.20. Pavement User for Charges for Road Class 8, \$/km

Vehicle Class		Payload				
		Empty	1-10 t	10-30 t	30-50 t	>50 t
Passenger Cars	MC	0.00000029				
	Price	0.010				
Tractor + Single, Tandem and Tridem Semitrailers	MC	0.0018	0.0023	0.0067	0.022	
	Price	0.020	0.0023	0.0067	0.18	
Tractor + 3 and 4 Axle Semitrailers	MC	0.0022	0.0033	0.010	0.032	0.060
	Price	0.050	0.0033	0.019	0.26	0.37
Tractor + 5 or more Axle Semitrailers	MC	0.0024	0.0032	0.0074	0.021	0.039
	Price	0.050	0.0032	0.0074	0.18	0.30
Tractor + Heavy Haul A and B-Trains	MC	0.0019	0.0027	0.0071	0.018	0.032
	Price	0.050	0.0027	0.0071	0.18	0.30
Tractor + 2 and 3 Axle B-Trains	MC	0.0020	0.0028	0.0069	0.019	0.033
	Price	0.050	0.0028	0.0069	0.18	0.30
Single Unit Trucks	MC	0.00033	0.0019	0.026		
	Price	0.019	0.0019	0.067		
Truck Trailers	MC	0.00034	0.00076	0.0066	0.031	0.063
	Price	0.019	0.00076	0.0066	0.26	0.38

Table 5.21. Pavement User for Charges for Road Class 9, \$/km

Vehicle Class		Payload				
		Empty	1-10 t	10-30 t	30-50 t	>50 t
Passenger Cars	MC	0.00000015				
	Price	0.005				
Tractor + Single, Tandem and Tridem Semitrailers	MC	0.00092	0.0012	0.0034	0.011	
	Price	0.013	0.0018	0.0060	0.09	
Tractor + 3 and 4 Axle Semitrailers	MC	0.0011	0.0017	0.0051	0.016	0.030
	Price	0.033	0.0023	0.008	0.14	0.18
Tractor + 5 or more Axle Semitrailers	MC	0.0012	0.0016	0.0037	0.010	0.020
	Price	0.033	0.0023	0.0064	0.09	0.15
Tractor + Heavy Haul A and B-Trains	MC	0.0010	0.0014	0.0036	0.0091	0.016
	Price	0.033	0.0020	0.0063	0.09	0.14
Tractor + 2 and 3 Axle B-Trains	MC	0.0010	0.0014	0.0035	0.0094	0.017
	Price	0.033	0.0021	0.0061	0.09	0.15
Single Unit Trucks	MC	0.00017	0.0010	0.013		
	Price	0.009	0.0010	0.016		
Truck Trailers	MC	0.00017	0.00038	0.0033	0.016	0.032
	Price	0.009	0.00038	0.0033	0.13	0.20

It can be observed from the tables that the general trend of prices allocated to different cells is that a relatively high price is attributed to empty vehicles and it decreases up to a certain load and again increases. High fees should be allocated to both empty and heavy vehicles because of low output and greater damage, respectively.

To show this trend better the ranges of the allocated pavement charges across different pavement types are calculated and shown against payload in Figures 5.5 to 5.11. Dashed lines in the figures correspond to illegal vehicle loads as defined by the Ontario Highway Traffic Act. The figures also show the corresponding marginal costs. As can be observed from the figures each price graph has a minimum point which reflects the optimum payload associated with each vehicle group. As payload deviates from that point, charges increase significantly. As the figures illustrate, all prices attributed to different vehicles are greater than the marginal costs of the vehicles. Payloads close to the point where the pavement charges are minimum are the optimal loads from a road agency point of view.

Both the optimal and illegal payload ranges are shown in Figures 5.5 to 5.11. There is only one optimal payload point associated with each vehicle group, but it may not be feasible to expect vehicles to operate exactly at those levels even if the enforcement and pricing strategies are influential. Besides, the optimal payloads vary within each vehicle group depending on the configuration of different vehicles in each group. The approximate ranges of optimal payloads for different vehicle groups have been identified and are shown in the figures. As can be seen from the figures, the game-theoretic cost allocation method has assigned prices equal to or close to marginal costs of the vehicles operating at optimal payload ranges. There are larger differences between the price and the marginal cost attributed to different vehicles for inefficient situations.

As explained before, the idea with this trend of charging is to encourage vehicles to operate at the optimal payload levels. The influence of these charges on the decision and behaviour of road users are discussed in Chapter 8.

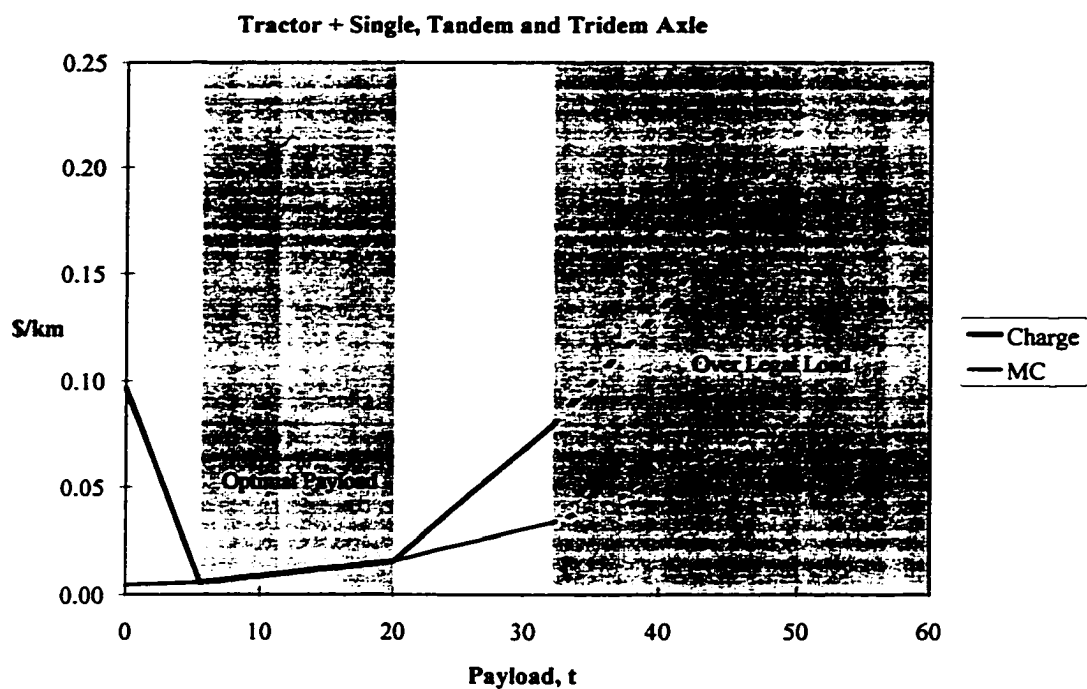

Figure 5.5. Marginal Cost and Road User Charge versus Payload, Vehicle Type 2

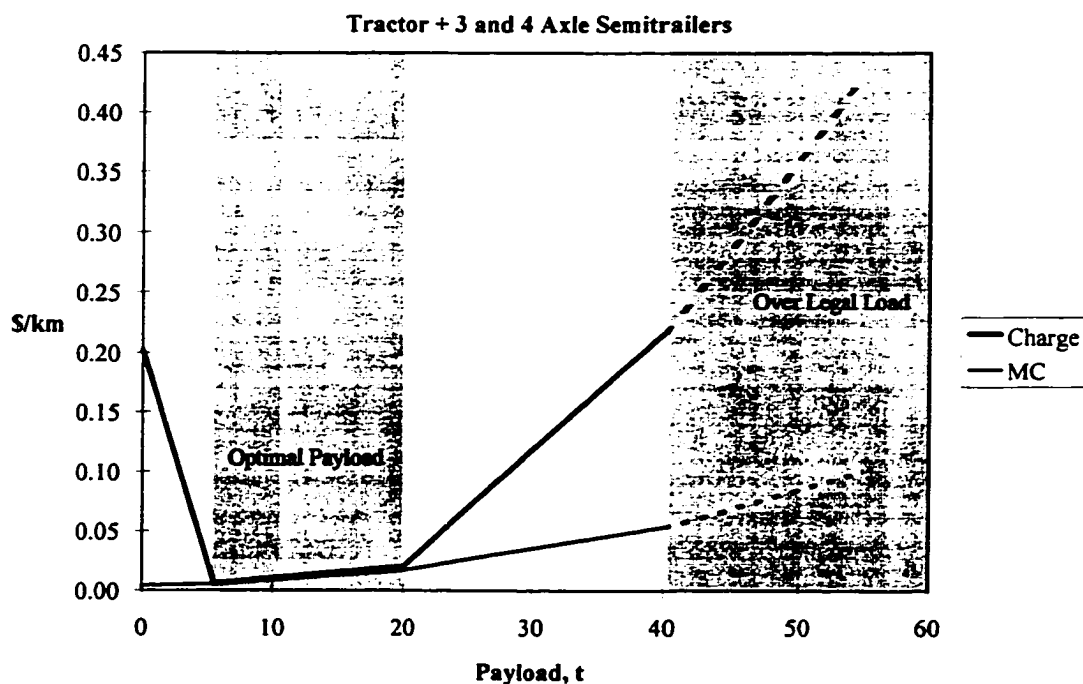

Figure 5.6. Marginal Cost and Road User Charge versus Payload, Vehicle Type 3

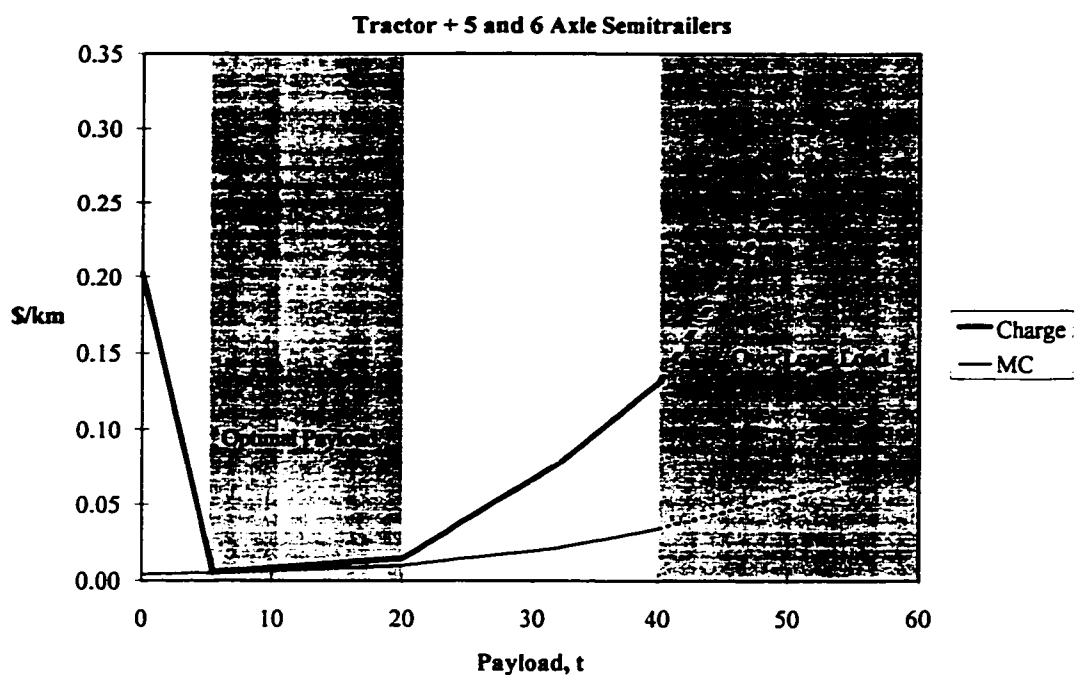

Figure 5.7. Marginal Cost and Road User Charge versus Payload, Vehicle Type 4

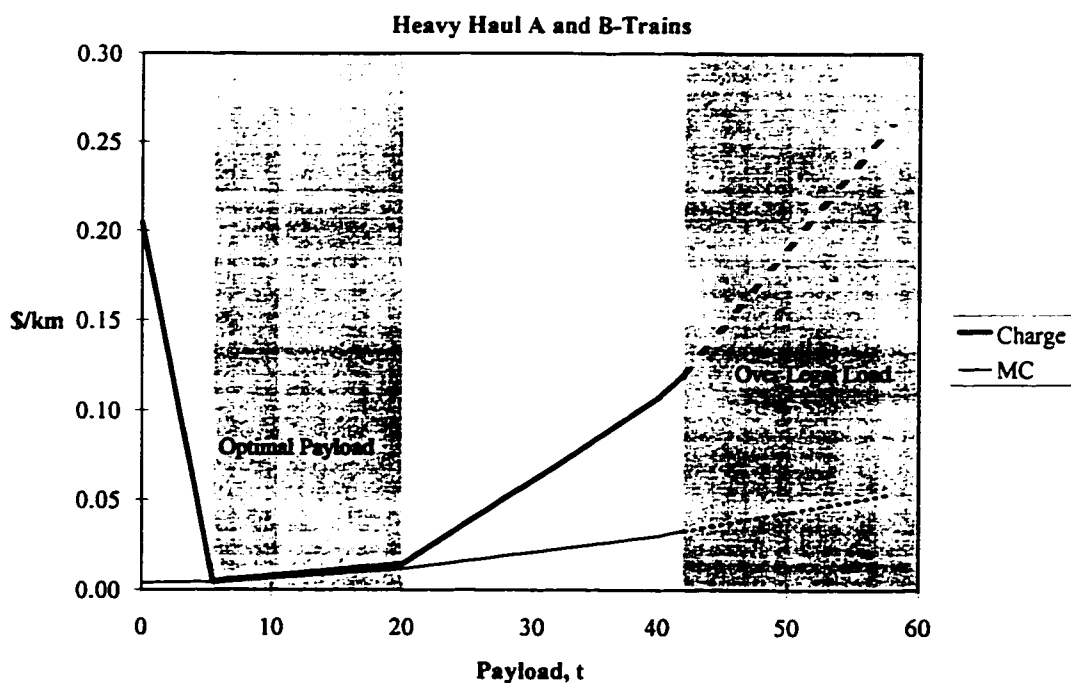

Figure 5.8. Marginal Cost and Road User Charge versus Payload, Vehicle Type 5

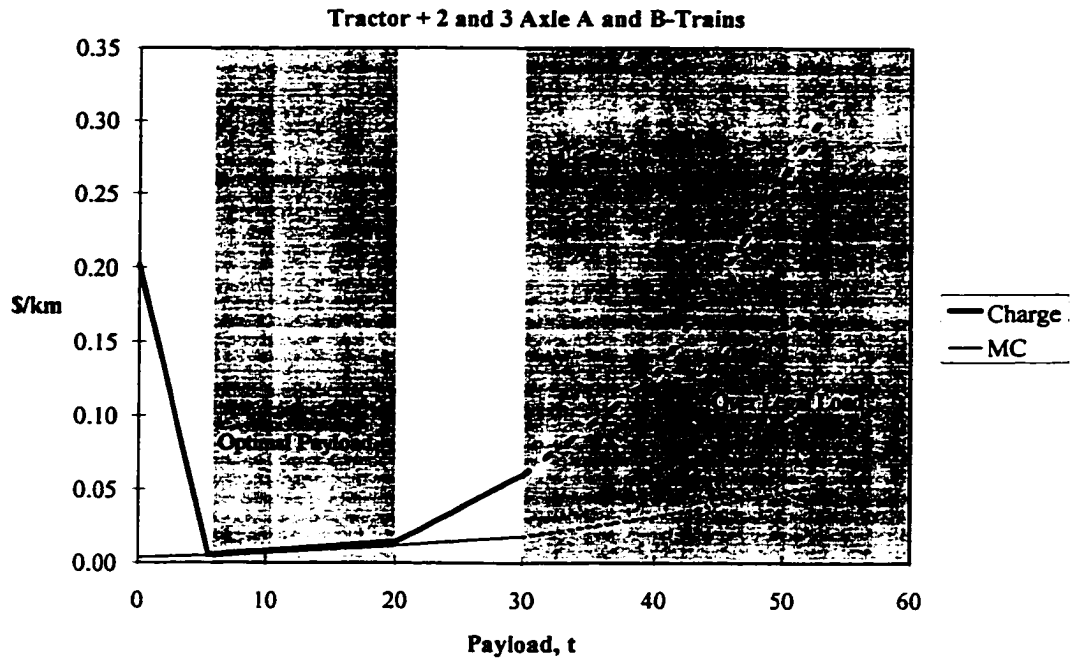

Figure 5.9. Marginal Cost and Road User Charge versus Payload, Vehicle Type 6

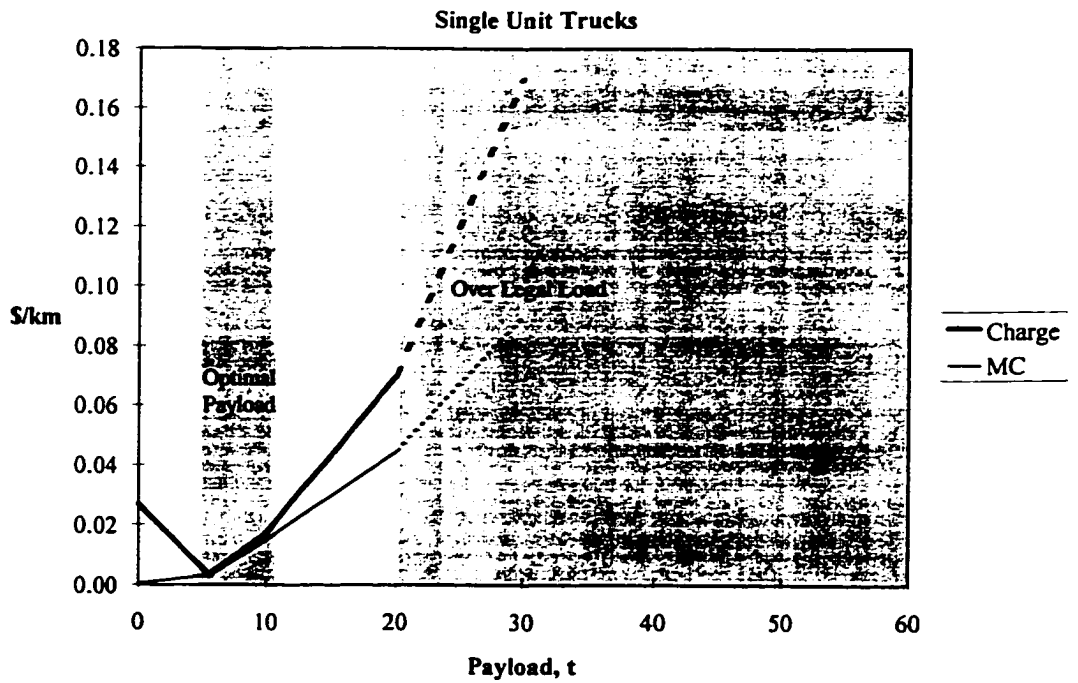

Figure 5.10. Marginal Cost and Road User Charge versus Payload, Vehicle Type 7

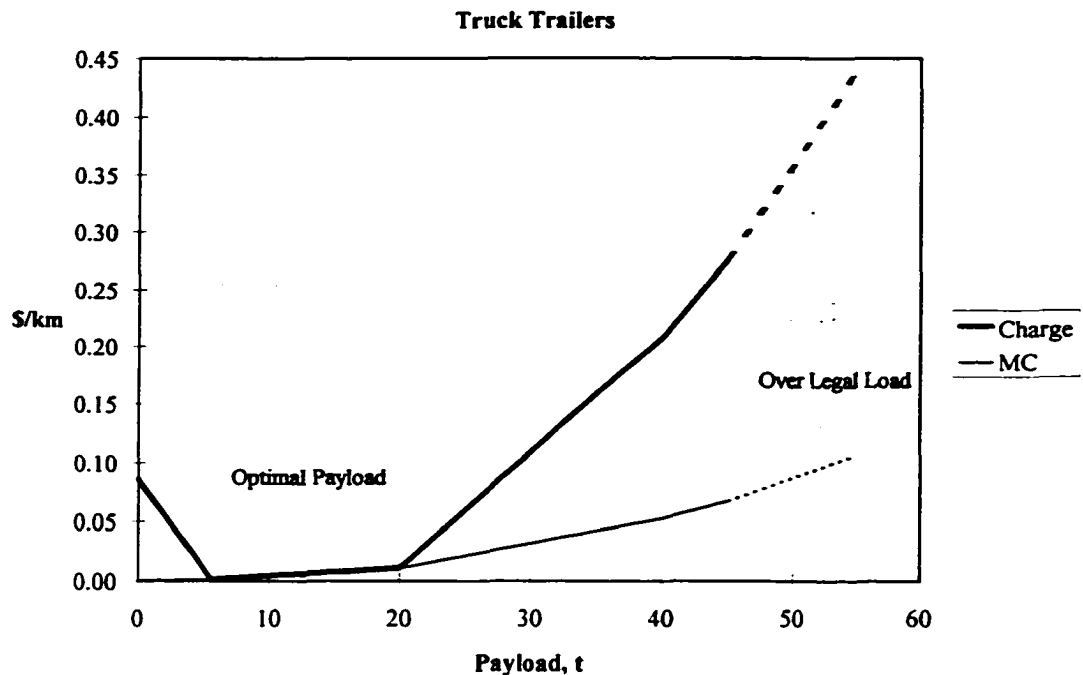

Figure 5.11. Marginal Cost and Road User Charge versus Payload, Vehicle Type 8

In this analysis pavement prices are set in such a way that relatively higher prices are attributed to vehicles which incur higher pavement damage cost per unit of payload. For example, in the case of semitrailers with large number of axles, the pavement damage cost for payloads between 5 t to 20 t (i.e., optimal payload range) is on average 0.00060 \$/t-km and the price attributed to such vehicles is on average \$0.00080 \$/t-km. In the case of illegal payloads (i.e., over 42 t), damage to pavement is about \$0.00097 \$/t-km, while 0.0042 \$/t-km is allocated to such vehicles. The difference between prices and marginal costs are significantly higher for illegal loads. This can lead to significantly higher road prices for vehicles carrying illegal loads.

Rational relationships can be seen between pavement prices and pavement damage costs. For example, for low payloads, the minimum cost has been attributed to truck trailers which have low tare-weight and have low axle loads when carrying light payloads up to 10 t. For heavy loads, minimum prices are attributed to A and B-Trains as they impose minimum damage to pavements per unit of payloads when carrying heavy

loads. Overall, single unit trucks and truck trailers are the optimal vehicles for light loads, semitrailers with large number of axles are the optimal vehicles for medium payload weights (between 20t to 30t), A and B-Trains are the optimal vehicles for carrying heavy payloads (over 30 t).

Some restrictions have been set in the MP framework for cost allocation analysis in this research that assign penalties to empty vehicles. This is because the empty vehicles are practically inefficient, although their absolute damage costs are low. The tare-weight of these vehicles impose some damage to the pavements while their outputs in terms of carried cargo are limited. This way of pricing may help to decrease the percentage of empty vehicles in the system and encourage road users to utilize their vehicles more efficiently.

The most important contribution of this chapter was to set a game-theoretic cost allocation framework and to carry out appropriate road user charges for the pavement costs of the Ontario highway system. Overall, it was shown that the proposed method is capable of defining the charges to specific users at a disaggregate level. Although a practical system may not be designed to collect the charges at a very disaggregate level, this characteristic of the method extends the understanding of the relationships between the implications and characteristics of the practical charges. The theoretical charges by which the system is supposed to perform at the optimal level were also discussed.

CHAPTER 6

Bridge Cost Analysis

6.1. INTRODUCTION

This chapter describes the general aspects of bridge design procedures and the factors influencing bridge costs. Characteristics of bridge costs in Ontario as well as a summary of the bridge costs for different design scenarios are described at the end of the chapter.

Bridges have an expected useful life of 50 to 100 years and like pavements they need to be maintained or repaired during their useful life (Xanthakos, 1996). Bridge life-cycle costs usually consist of a large initial construction cost plus some maintenance and rehabilitation costs at different times throughout their life. The capital costs of bridge construction is the most important cost element in the bridge cost life-cycle.

The process of bridge deterioration is different from that of pavements. In general analyzing the cost effects of traffic and environmental factors on bridge deterioration are more complex than for pavements. Some of the fundamental differences which make the bridge cost analysis more complex include:

1. Bridges last much longer than pavements and the deterioration of bridges is primarily due to environmental factors and deicing chemicals (Ariaratnam,1994).
2. Bridge structural failure is often as a result of poor original design or the occurrence of several vehicles simultaneously on the bridge (not all of which have to be overweight). Bridge failure is infrequent but if it does happen, it may have severe cost consequences.
3. Certain vehicles or subsets of vehicles affect different bridge spans in different ways.
4. As a result of the severe social and economic effects of bridge failure, high safety margins have been incorporated into bridge design standards. This implies that the effects of traffic loadings on bridge damage relative to environmental factors must be limited.

The analysis of bridge deterioration has received less attention than pavement deterioration and less effort has been made in collecting and modelling bridge costs compared to that of pavements. Therefore, some estimates and assumptions have been incorporated in this study because there is little empirical and theoretical information about bridge deterioration models. These approximations are justified due to the fact that bridge costs constitute only a small percentage (about 14%) of the total road costs in Ontario.

6.2. BRIDGE DESIGN CONCEPTS

6.2.1. General Specifications

A bridge may be defined as a structure which carries traffic over an obstacle such as river, highway or railway. There are different forms of bridge structures (e.g., arch, truss, box, etc.) but the majority of the modern highway bridges are the slab-on-stringer type structures as shown in Figure 6.1 (Tonias, 1994). Over 75 percent of bridges in Ontario are slab-on-stringer bridges (MTO, 1996). The focus of this chapter is on the cost characteristics of the slab-on-stringer bridge structures in Ontario.

Highway bridges consist of three major components: *i*) superstructure, *ii*) deck, and *iii*) substructure. The superstructure is the major part of a bridge which carries the roadway over a crossing. The deck is located over the superstructure and makes up the supporting base for the pavement layer on which vehicles operate. The substructure supports the superstructure and transmits the loads from the superstructure to the bridge foundations.

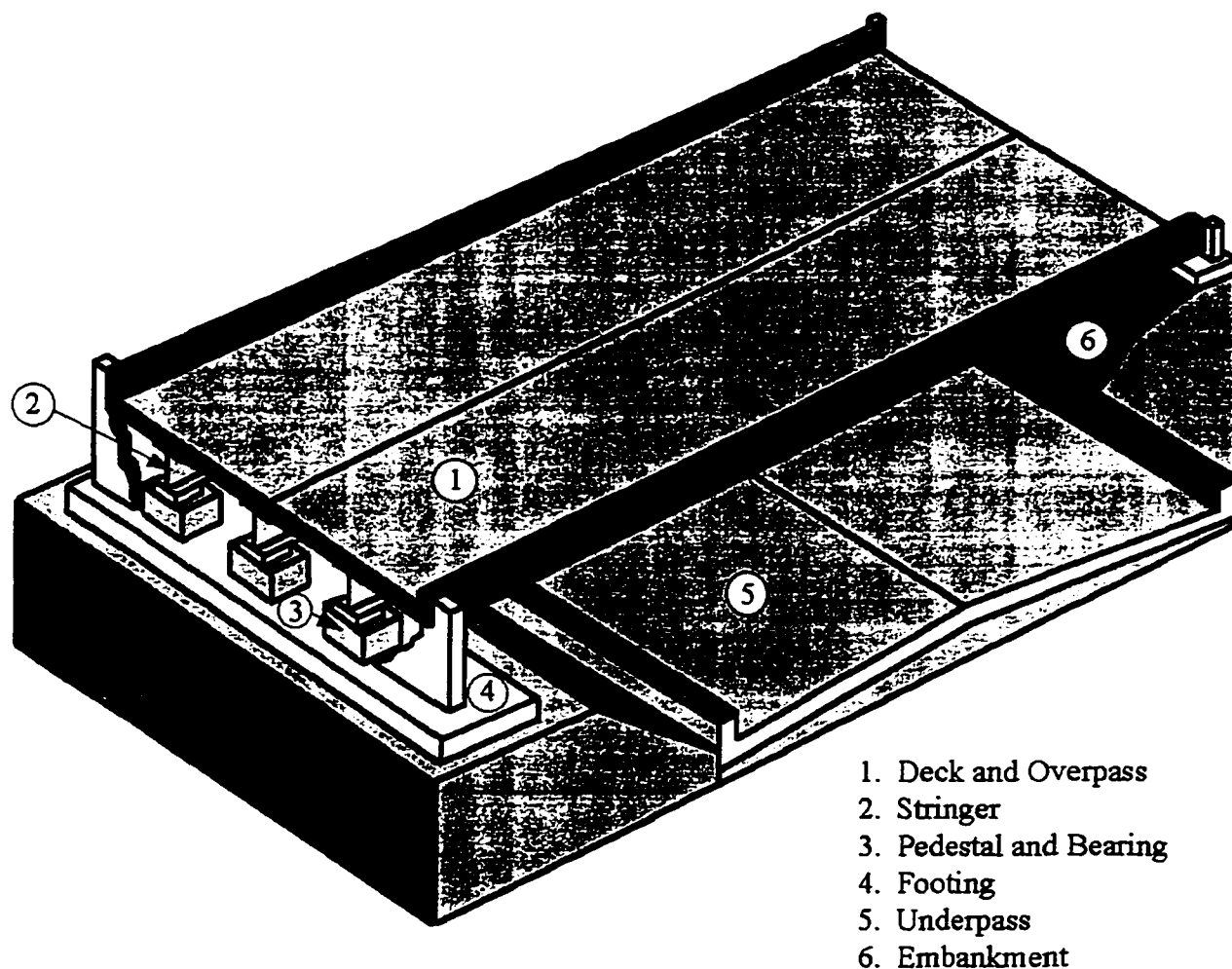

Figure 6.1. Single Slab-On-Stringer Bridge and Its Components (Tonias, 1994)

Selection of the type of bridge material and structural system used is governed by requirements of structural safety as well as the cost of bridge and technology of

construction available at the construction site. In terms of material type, usually steel or concrete are the first choices and the material selection mainly depends on the cost implications of different material types and time limitations for construction. The design of bridge decks consists of the design of the slab itself, its pavement, and its joints. The major design elements of the superstructure are the supporting beams and the secondary members that protect the supporting beams against buckling and twisting. Substructure design includes the design of bearings, pedestals, piers, footings and piles. Design of the elements of highway bridges in Ontario is subject to specific standards proposed by MTO and is described in the latest edition of the Ontario Bridge Design Code (MTO, 1991). The Ontario Bridge Design Code also provides bridge engineers with guidelines for structural design and loading standards as well as allowable stresses and deflections. In addition to the standards for bridge structural elements, the Ontario Bridge Design Code provides guidelines for geometric specifications of bridges as well as specifications for safety elements such as sidewalks and guardrails.

6.2.2. Design Loads

Bridges are subject to different types of loads including: *i*) dead load, *ii*) live load and its dynamic impact, *iii*) longitudinal forces due to friction, *iv*) lateral load such as wind and earthquake forces, *v*) earth, water and ice pressures, and *vi*) forces resulting from thermal deformation. Usually the critical design loads are the dead and live loads together. However, in long span bridges the effects of dead loads may be more influential than live loads. A single type of load may impact different bridge structures in different ways depending on the structural specifications. For example, in the case of long span bridges, gross vehicle weight plays the most significant role in bridge damage, while axle loads, axle spacing, and suspension design are more critical parameters for short spans. Therefore, critical loading for bridges with short span lengths is generally caused by single heavy axles. For long-span bridges the concurrent presence of multiple vehicles may be more critical.

Vehicular live load of highway bridges is expressed in terms of Truck or Lane Loads. The Ontario Bridge Design Code expresses each lane load as either a standard truck, as shown in Figure 6.2, or a standard truck with each axle load reduced to 70% superimposed with a 3 m wide uniformly-distributed load of 10 kN/m. The Ontario Design Truck has been developed to represent the configurations of real trucks operating in Ontario and comprises a large number of truck axle weights and spacings (Hutchinson, 1989). For multiple-span bridges, the uniformly-distributed load is only applied where it increases the load effect.

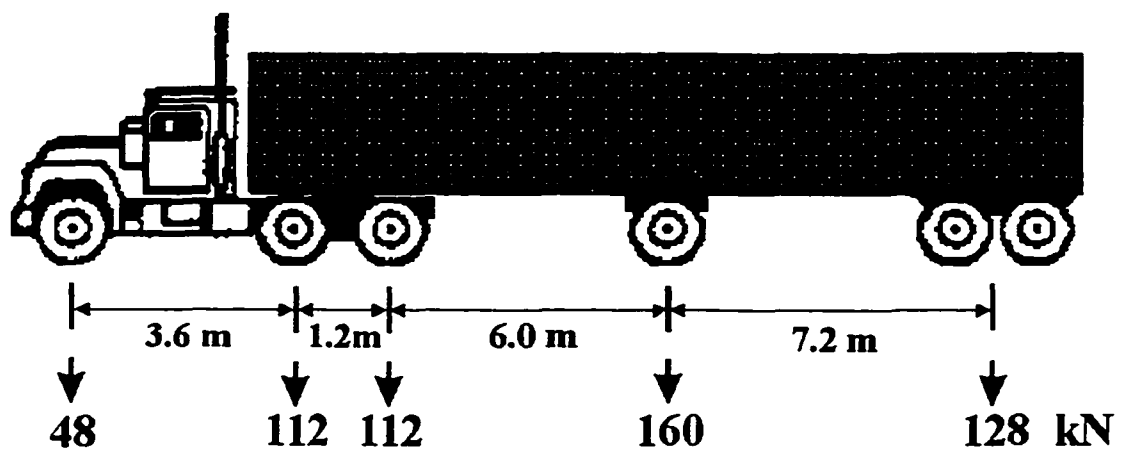

Figure 6.2. Ontario Bridge Design Reference Truck (MTO, 1991)

6.2.3. Design Methods

In general, there are two principal methods used for bridge design procedures. These methods are: *i*) working stress design and *ii*) limit state design. The former design method has a longer history than the latter. Originally most bridges were designed based on the working stress design method. However, general acceptance of the limit state design method began in the 1970's. The Ontario Bridge Design Code has been redeveloped based on the limit state design since 1979. The working stress design is an approach by which structural members are designed so that unit stresses do not exceed a

predefined allowable stress which is determined by a limiting stress divided by a factor of safety as shown by equation [6.1].

$$f_{actual} \leq f_{allowable} = \frac{f_y}{FS} \quad [6.1]$$

where,

f_y = Minimum yield stress

FS = Factor of Safety

In the working stress method, the actual stresses are representative stresses caused by working loads. The structure is designed not to experience stresses which may fall beyond the elastic range of the materials used in the bridge structure. The elastic range provides engineers with a known safe region within which the structural design can be confidently achieved.

A limit state is a condition which represents the limit of structural usefulness (AISC, 1986). The limit state design employs the plastic range for the design of structural members and incorporates load factors that consider the variability and stochastic nature of loading occurrences. In general, the objective of limit state design procedure is to ensure that the structural strength is greater than the actual structural forces caused by appropriate load factors as shown by Equation [6.2].

$$\Phi S_n \geq \sum \Psi_i L_i \quad [6.2]$$

where,

Φ = strength reduction factor,

S_n = nominal strength,

L_i = service load acting on the member's nominal strength, and

Ψ_i = load factor reflecting the uncertainty of L_i .

In the limit state design method different load factors would be considered for different load types according to the uncertainties involved in their occurrence. For example, if only dead and live loads are considered, the strength required would be dead load times some factor plus live load times another factor. Load factors for bridge design in Ontario are described in the Ontario Bridge Design Code.

Comparison of the methods implies that the working stress method is better suited for steel than concrete. Steel is an elastic material, its stress to strain is relatively proportional up to the yield point of steel. Within the elastic range there is no permanent (plastic) deformation. The application of the working stress method for the design of structural components using concrete materials, therefore, results in designing at a level that is much below the failure level of concrete because concrete behaves elastically up to a stress that is roughly half of its compressive strength (Tonias, 1994).

6.2.4. Internal Forces

Bridge loads are transmitted from the deck to the superstructure and then to the substructure. When a vehicle is traveling over the deck, one or several of the primary members (e.g., stringer) of the superstructure withstands the vehicle load. The stringers are connected to each other through some secondary members such as diaphragms and cross-frames. These loads are transmitted to substructure elements through bearings. Several factors may influence the distribution of load among different bridge elements: *i*) type of bridge, *ii*) type of deck, *iii*) spacing between elements, *iv*) stiffness of the elements, *v*) size and position of load (Cooper, 1985). The distribution of loads may influence the total cost of the bridges. However, for a given design load it has been found in this research that the unit cost of bridge construction does not vary much for different bridge specifications (e.g., length, width, structural type, etc.). This may be justified by the fact that there may be several choices of material and structural types as well as construction technologies available to bridge engineers. They can optimize the bridge costs by choosing optimal bridge design strategy.

6.2.5. Bridge Design Procedure

Figure 6.3 presents the general steps involved in bridge design procedures. The first step is to decide what kind of material and structural system would provide the safest and optimal life-cycle costs for each bridge project. The type of bridge components may be chosen based on a variety of factors ranging from technical and economic reasons to personal preferences. In general some of the commonly used criteria in selecting the type of a bridge structure are: *i*) material characteristics and availability, *ii*) speed of construction, *iii*) complexity of design, *iv*) maintenance, *v*) environmental concerns, and *vi*) total costs.

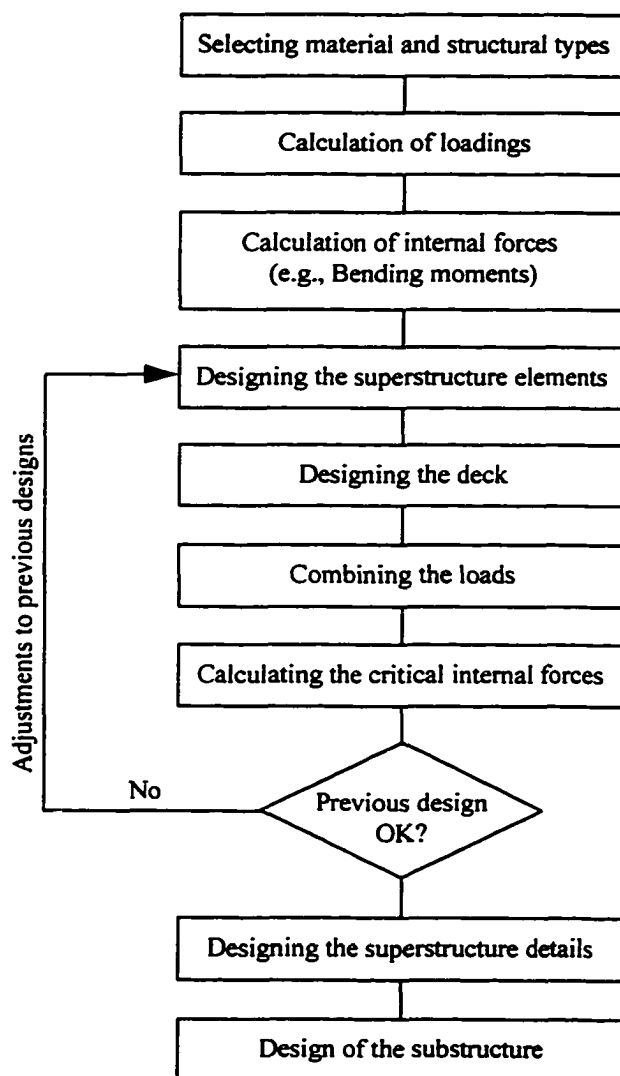

Figure 6.3. Bridge Design Procedure (Merritt et al., 1996)

The second step is to determine the loads affecting the bridge structure and the critical internal forces generated by those loads. The next step is to estimate the specifications of deck and superstructure elements. This is one of the most challenging design problems in bridge engineering projects. Bridge decks vary based on material type and structural configuration. The deck can also serve as the bridge superstructure in some cases (usually short span bridges).

After designing the deck and superstructure components, the dead loads can be estimated. At this stage the total load, including the dead and the live loads, should be calculated and combined with appropriate load factors. Then, the critical internal forces such as maximum bending moments should be calculated at different locations on the bridge. This step requires moving live loads along the bridge to find the situation where the maximum forces occur. A series of computer programs have been developed in this research to accomplish this task for single and continuous span bridges through the calculation of influence lines. Influence lines are useful tools, they represent the bending moment and shear effect of a unit load on a specific point for a set of moving loads. This technique simplifies the calculation of maximum bending moment effects of different combinations of loads at different locations on a bridge.

After completing the superstructure design, the substructure including abutments, piers and piles should be designed. Unless the bridge structure is a rigid frame, the substructure works as a separate system. The loads transmitted from the superstructure at each bearing influence the design of the substructure and foundation.

6.3. CHARACTERISTICS OF BRIDGES IN ONTARIO

6.3.1. General Information

There are almost 4,500 bridges and culverts (3,200 bridges and 1,400 culverts) which constitute more than 3,000,000 m² of deck area in Ontario. Figure 6.4 shows the mixture of bridge types in Ontario (MTO, 1996). As it may be seen from the figure, more

than 93 percent of the Ontario bridges are concrete bridges. The rest are constructed of steel or timber.

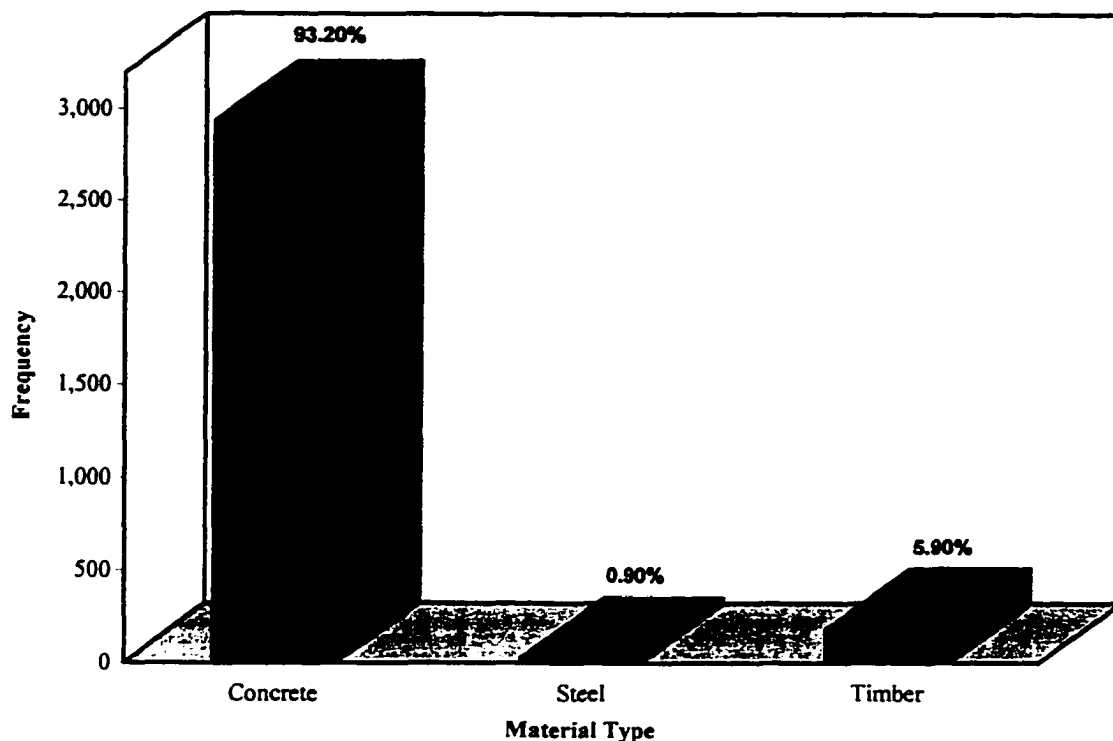

Figure 6.4. Number of Provincial Highway Bridges By Material Type (MTO, 1996)

Assuming a construction cost of \$1000 /m² (see section 6.3.2), the net asset value of bridges in Ontario would be about \$3 billion. Assuming an average bridge life of 75 years, over 40 bridges should be rebuilt each year in Ontario at an estimated cost of \$40 million per year. Besides this, there are the maintenance and rehabilitation costs of existing bridges whose lives are not yet terminated. Figure 6.5 shows the frequency and variation of different bridge lengths in Ontario. There are about 1400 bridges less than 10 m long, most of which are culverts. The majority of bridges are between 10 m and 110 m long and are the focus of the analyses in this chapter.

6.3.2. Estimation of Bridge Costs

There are some bridge cost data available for different bridges at different locations in Ontario (data obtained from Dillon M. M. Ltd., Toronto). The source of these data are mainly bridge contract documents at MTO. Some preliminary analyses of bridge cost data in this study indicated that the total cost per unit of deck area is within a narrow range for most bridges. This implies that a linear relationship may be assumed between bridge construction cost and deck area. Cost data have been categorized for Central, Eastern, Northern, Southwestern and Northwestern Ontario and regression analysis has been utilized to develop linear models to estimate the bridge costs for different regions. These models are compared on a pair-wise basis in Table 6.1 and the results of the F-test values are shown.

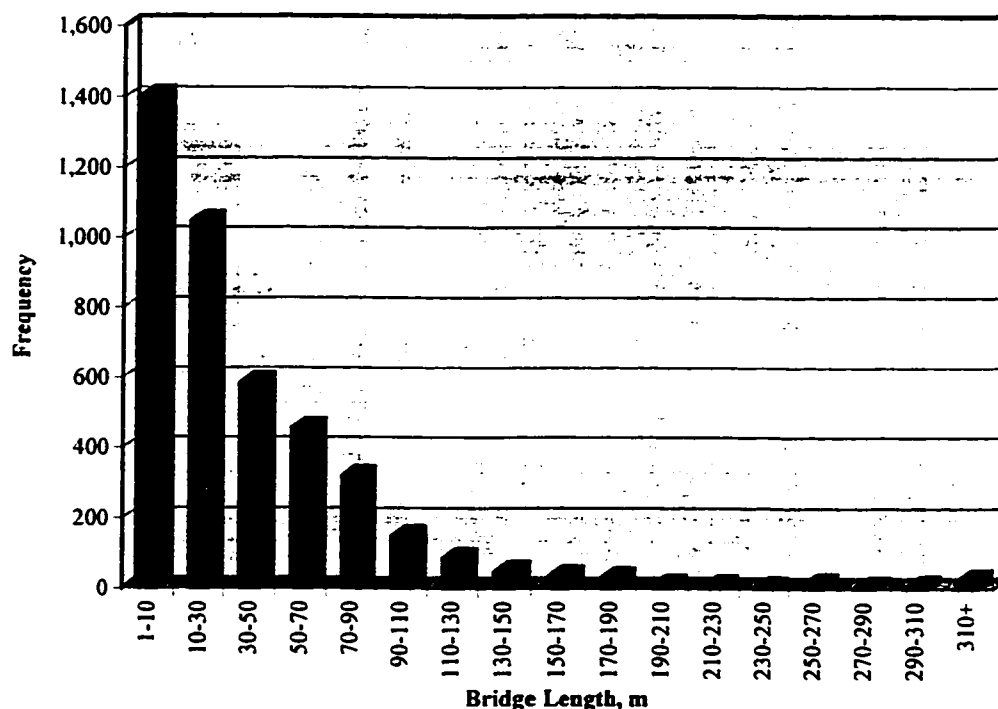

Figure 6.5. Provincial Highways - Number of Bridges By Total Length

Data from Table 6.1 indicates that a single regression equation may be satisfactorily used for central, eastern and northern regions. Further analysis showed that a regression equation developed for the combined data for these regions was not

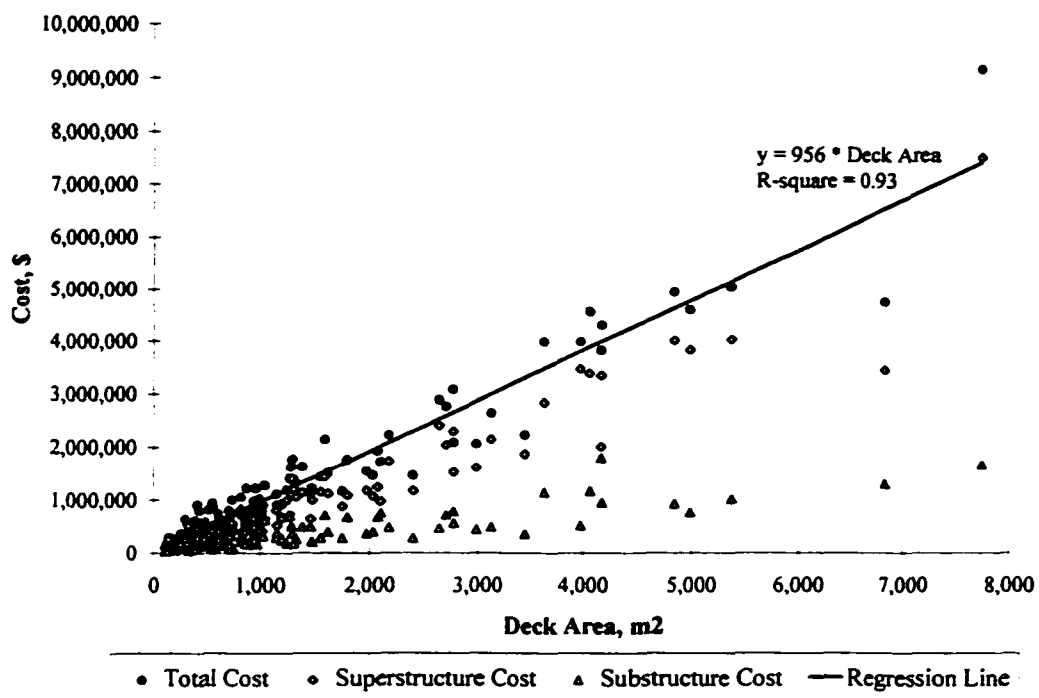

Figure 6.6. Bridge Construction Cost for all Regions of Ontario Except Northwest

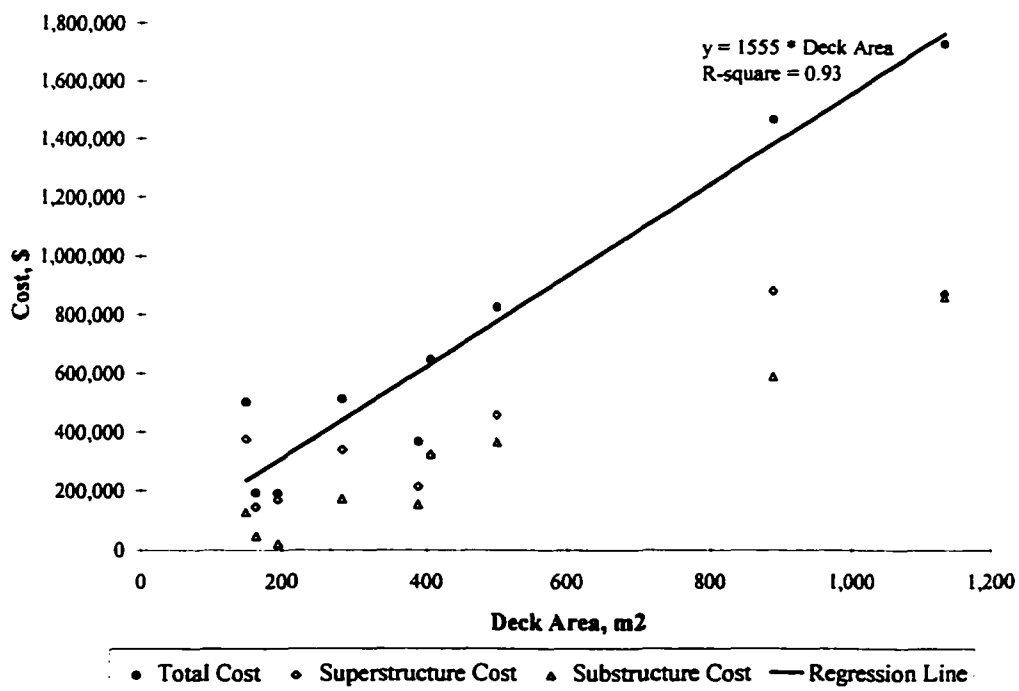

Figure 6.7. Bridge Construction Cost for all Northwestern Ontario

According to American studies (Xanthakos, 1996) the annual maintenance cost of bridges is a very small percentage of total costs of bridge construction (less than 0.2 percent). Assuming an average of 75 years of bridge life, the total bridge maintenance costs accounts for only 2 to 4 percent of total bridge costs. These figures imply that the most important element in bridge life-cycle costs is the initial construction cost. Previous studies indicate that deterioration of bridges is mostly a result of aging and environmental factors rather than fatigue or other traffic related factors (Moses, 1989; Bannantine et al., 1990).

Based on the above information it can be concluded that the marginal bridge damage costs associated with different vehicles, if they exist at all, are very small compared to the bridge construction costs. This is especially true for concrete bridges which are by far the majority of bridges in Ontario. There is no detailed information available on the maintenance costs of different bridges in Ontario and bridge deterioration models which can separate the environmental and traffic associated effects could not be found. Thus, for the purpose of cost allocation analysis, it is justifiable to focus only on the initial capital costs of bridges.

The dominance of initial outlay in bridge life-cycle costs and the low marginal damage costs imply that marginal cost pricing is not a proper approach for bridge cost allocation. These special characteristics of bridges suggest that the Incremental cost allocation approach may be appropriate for the purpose of bridge cost allocation analysis in this study. To carry out a cost allocation analysis based on the Incremental Method the respective bridge cost implications of different design loadings should be obtained and analyzed. This task requires the estimation of the specifications of each bridge element under different load scenarios.

An American bridge cost allocation study conducted by a team from the Department of Civil Engineering at Purdue University, USA, evaluated the cost implications of different truck configurations on different bridges in the state of Indiana (Tee et al., 1986). The research considered the cost implications of different AASHTO loadings for different bridge types including reinforced concrete slab, prestressed concrete

I and box-beams, steel beams and steel girders. The study investigated the relationship between different design loadings and the percentage of total actual costs for Indiana State bridges as shown by Figure 6.8. It can be observed from the figure that there is a minimum cost required to construct a minimum bridge. Bridges designed for heavier truck weights increase costs according to the square root of the design truck weight as shown by Equation [6.5]. This relationship, along with other results from the Indiana study has been used in this research to estimate the incremental bridge costs in Ontario.

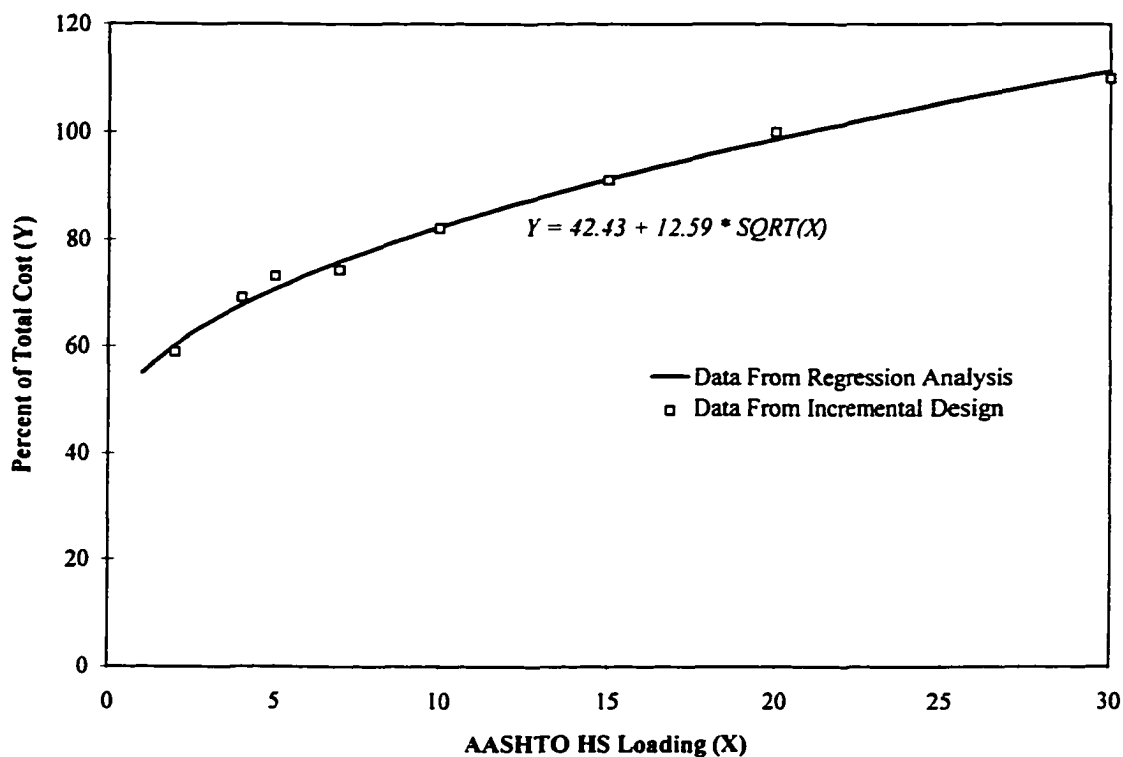

Figure 6.8. Relative Bridge Costs vs Design Loading (Tee et al., 1986)

$$\text{Percent of Total Cost} = 42.43 + 12.59\sqrt{X} \quad [6.5]$$

where,

X = AASHTO HS Loading.

AASHTO loadings represent traffic-related loadings by different standard trucks. The standard trucks specified by AASHTO are designated with an H or HS prefix

followed by a number which indicates the weight of the trucks in tons for two-axle trucks or for tractor-trailer combinations, respectively. AASHTO has introduced only five classes of design loads (i.e., HS 20, HS 15, H 20, H 15 and H 10). Other loadings can be obtained by proportionally changing the weights of the specified trucks of different AASHTO design loadings.

6.4. BRIDGE COST ANALYSIS AT NETWORK LEVEL

6.4.1. General Framework

As described before, different vehicles have diverse impacts on bridge costs depending on vehicle configuration and bridge structure. Heavier vehicles have more of an impact on long span bridges, while for short span bridges particular axle groups control the bridge design regardless of the gross vehicle weight (GVW). These factors together generate a diverse range of cost effects for vehicles operating at different loads and on different bridges. Similar to the pavement cost analysis, bridge cost allocation analysis requires the estimation of bridge costs at the network level since all the users of the road system should pay for the bridges. The 1996 Ontario Bridge Inventory database is the source of input for bridge cost analysis in this research. The inputs include total bridge length and width, span length, location of the bridge and year of construction. The construction cost for each of the bridges is calculated based on developed regression functions (Equations [6.3] and [6.4]).

The present worth and equivalent uniform annualized costs of each bridge are calculated by considering the year of construction and assuming an average useful bridge life of 75 years. The equivalent annualized costs can be calculated by Equation [6.6].

$$EUAC = PW \frac{i (1+i)^{75}}{(1+i)^{75} - 1} \quad [6.6]$$

where,

$EUAC$ = equivalent uniform annualized costs,
 PW = present worth cost, and
 i = discount rate.

It is assumed that the users during the life of each bridge are responsible for the cost of that bridge. In this regard, the present value of the bridges are calculated for 75 years of bridge life and the value of the remaining useful life of bridges plus the present worth of the costs required to extend bridge services for 75 years are considered in the analysis. For example, if a bridge is built 25 years ago, the present worth of the remaining value of the bridge for the next 50 years is calculated. Also, it is assumed that the bridge will be replaced with a new one after 50 years. The present value of the first 25 years of the new bridge is also calculated and is added to the present capitalized value of the existing bridge. The present worth values of Ontario bridges were then converted to the equivalent uniform annualized costs for 75 year time period.

The next task is to categorize calculated bridge costs for different vehicle, load and traffic situations. To have a consistent relationship with the results of pavement cost allocation analysis, the same road and vehicle classifications are used. One of the classifications in pavement cost analyses was the range of annual ESALs associated with each road type. The ESAL term is irrelevant for bridges since it represents the effect of truck loads on pavement damage not bridge damage. The number of ESALs associated with each road link is correlated with the truck traffic on the link and with the total traffic level of that road section. Therefore, classifying the bridge costs based on the number of ESALs operating on each bridge can not only provide consistency with the classifications used for pavements, but also represents the traffic level associated with each bridge.

The next step is to find the costs associated with different load scenarios. The current Ontario bridge design guidelines are based on the Ontario Bridge Design Truck loading. This represents the maximum effect of actual vehicles operating on the road system. However, vehicles which do not have maximum impact may have lower costs if the bridges were designed to withstand their loads. To capture the cost implications of different design vehicles, the maximum internal forces created by different vehicle configurations should be estimated and compared. As explained before, the most critical factors affecting bridge costs are the maximum bending moment in the superstructure and axial loads in the substructure. The bending moment at the bottom of the bridge columns

may significantly influence the substructure design. However, this is a significant factor in rigid frame structures which are not common in Ontario.

A number of computer subroutines have been developed in this research to calculate the maximum bending moments of the superstructure. The programs calculate the maximum bending moment effect of different moving trucks on superstructures with various span lengths. The programs employ the influence lines for single, double and multiple span bridges. After calculating the critical forces in bridge elements new specifications for bridge members should be determined in order to proceed to calculate the cost of the new bridge. This task has been accomplished by employing Equation 6.5. However, because design truck and loadings in Ontario are different from AASHTO HS loadings (used as an independent variable in the equation), the equivalent HS loading of Ontario Design loads must be identified first. This task has been done by comparing the moments generated by Ontario Bridge Design loading with those generated by AASHTO HS loading for a number of typical bridges. It has been found that the maximum bending moments generated by Ontario Bridge Design loads are slightly greater than the moments generated by the HS 20 loading. For each bridge the equivalent HS loadings for different load scenarios are estimated and the respective costs for each scenario are calculated.

After calculating the cost implications of different load scenarios, the results were classified for different truck types, loads and traffic situations. A matrix similar to that used for pavement cost allocation has been established. For each cell (indicating vehicle class, load and road traffic situation) the maximum bridge costs (when the cell creates the maximum impact) as well as the percentage of usage of the system are calculated. These results were used for allocation of the bridge costs to different road users and are explained in more detail in the following chapter.

6.4.2. General Results

Figure 6.9 illustrates the frequency of Ontario bridges by their year of construction. As can be seen from the figure, the majority of bridges (about 90 percent) were built in the 1951 to 1996 period. The focus of this research is on the cost of bridges

in the last 50 years. This represents the time of construction of majority of the bridges in Ontario.

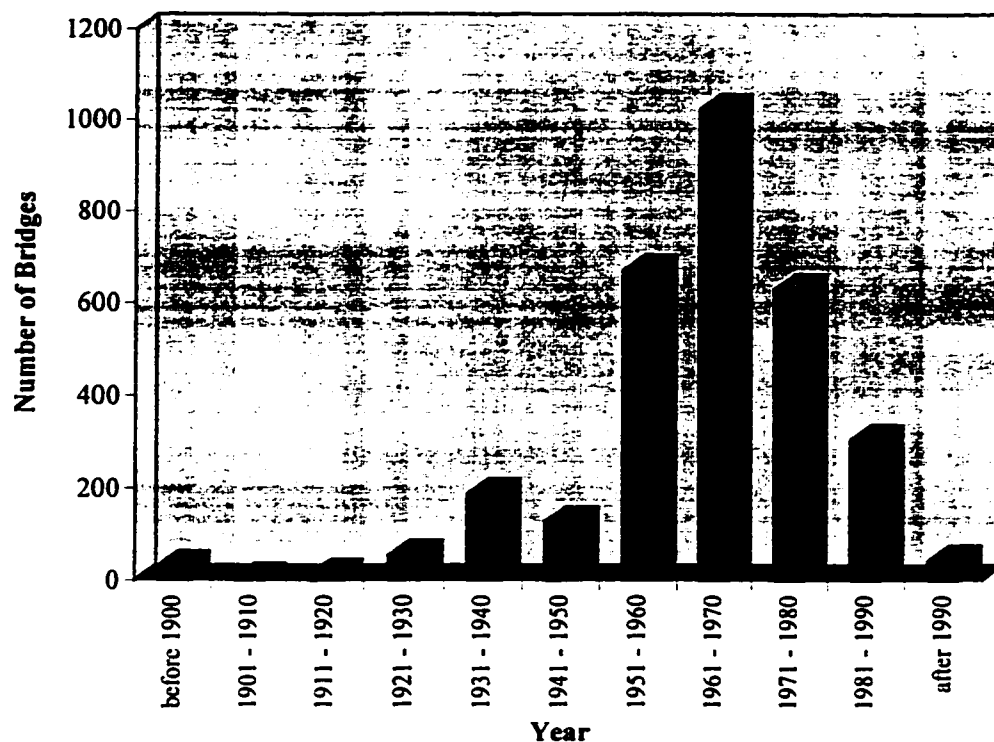

Figure 6.9. Frequency of Bridge Construction in Different Years

The system-wide analysis of bridge costs for the entire collection of bridges in the Bridge Inventory database in this research indicated that the equivalent uniform annualized cost of bridge construction in Ontario is about \$560 million per year. Road users must pay for this amount each year to recover the total bridge construction costs in 75 years, the average bridge life. This amount should not be equally distributed among different users since the bridges are designed for the maximum truck load impact. For the vehicle classes established in this research, it has been observed that 3 and 4 axle semitrailers (vehicle class 3) have the largest impact followed respectively by heavy haul A and B-Trains (class 6), 2 and 3 axle B-Trains (class 5), 5+ axle semitrailers (class 4), truck trailers (class 8), single and tandem and tridem semitrailers (class 2), and single unit

trucks (class 7). Figure 6.10 shows the present worth costs of bridge construction for different vehicle classes.

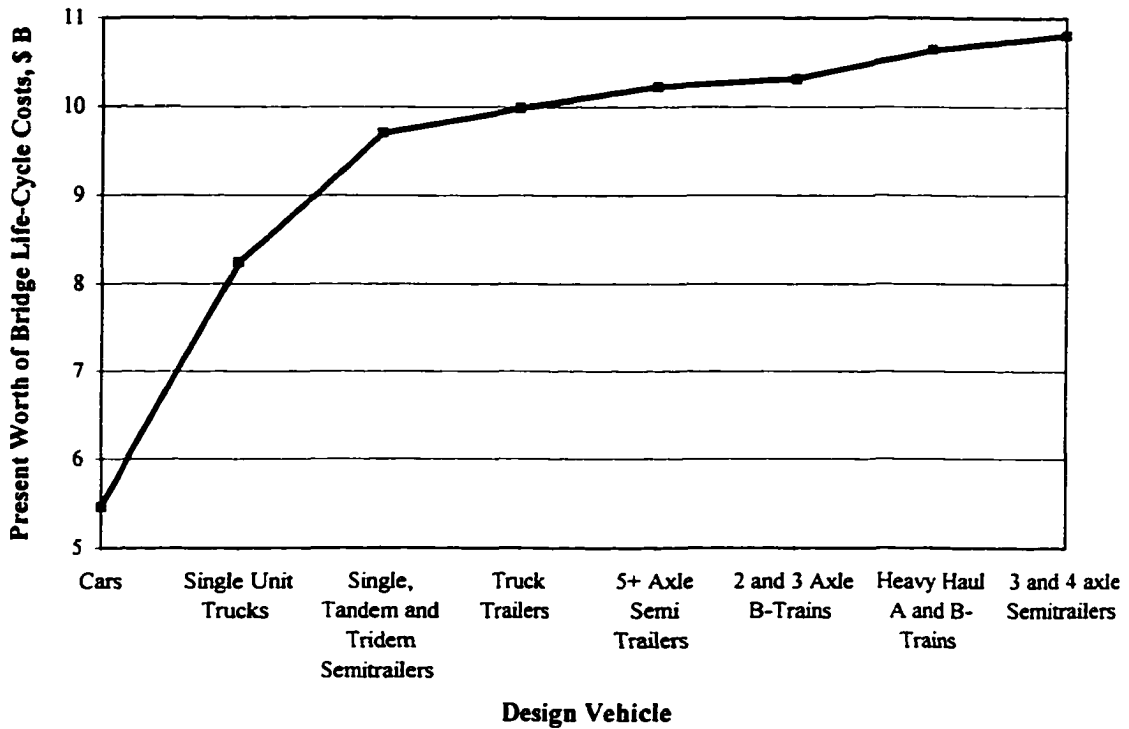

Figure 6.10. Present Worth Bridge Costs for Different Design Vehicle Scenarios

The bridge cost implications of different trucks carrying different payloads have also been analyzed. The results are illustrated in Figure 6.11. It is assumed that the existing bridges are designed for the most critical vehicles which have the largest impact on bridges. The figure shows that the critical vehicles impacting bridge structures are A and B-Trains as well as heavy semitrailers. It can be seen from the figure that the impact of large semitrailers is even slightly greater than Heavy Haul A and B-Trains. This mainly happens for heavy semitrailers with low number of axles, because of their high axle loads which have large impact particularly on short span bridge spans and structural elements. The figure also shows that cars have the lowest influence on bridge design. It can also be seen from the figure that if bridges were designed to withstand passenger car

loads, the annual construction cost of the bridges would account for about \$320 million as compared to \$560 million for the existing specifications.

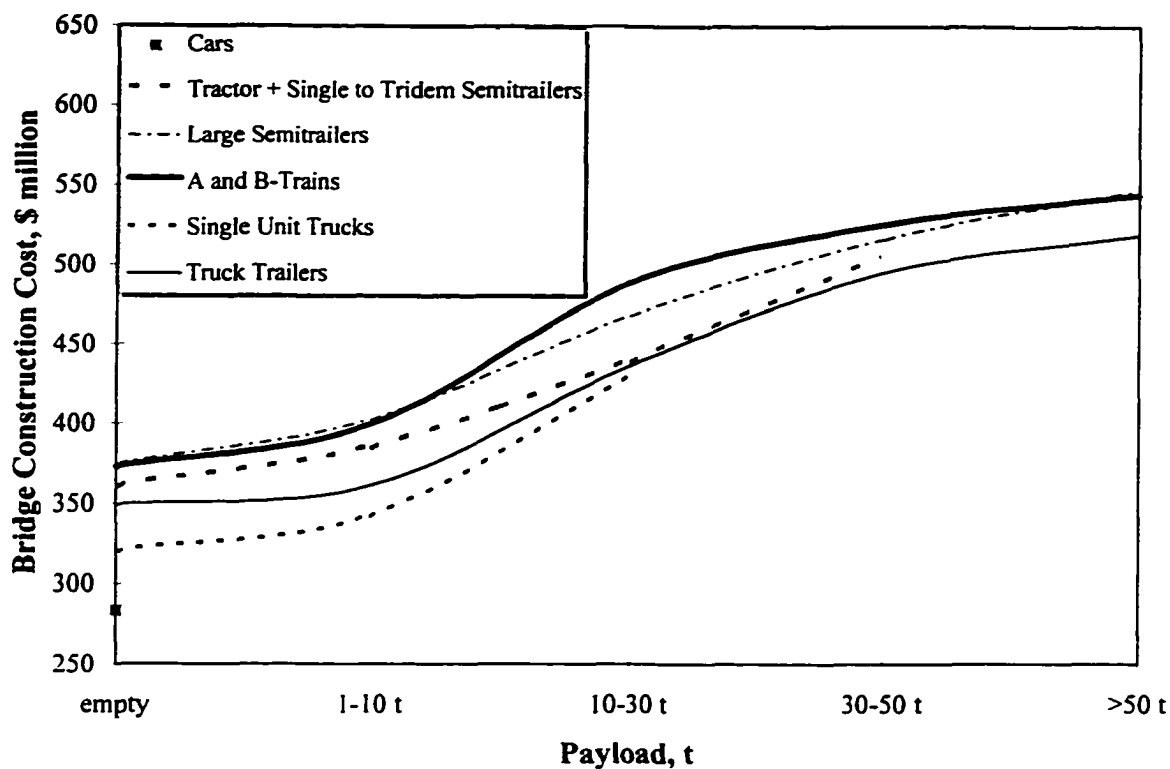

Figure 6.11. Annualized Bridge Construction Costs for Different Loads

The results of the system-wide cost analysis of Ontario bridges are used in the bridge cost allocation analysis (explained in the next chapter). In summary, the cost implications of different design truck scenarios are calculated and the bridge costs associated with different road classes are estimated for those scenarios.

CHAPTER 7

Bridge Cost Allocation Analysis

7.1. INTRODUCTION

This chapter provides information on the cost allocation analysis of Ontario bridges. As discussed in the previous chapter, the deterioration of bridges as a result of traffic-associated factors is insignificant compared to environmental effects. As explained previously, the maintenance and rehabilitation costs of pavements typically represent a significant percentage of their total life-cycle costs (up to 80 percent) while the bridge maintenance costs constitute only 0.2 percent of their life-cycle costs (Xanthakos, 1996). This implies that bridge cost allocation analysis should be formulated differently than that for pavements.

7.2. ANALYSIS FRAMEWORK

Due to the large safety margins specified by bridge design standards, the effect of traffic on the deterioration of bridges is found to be minimal, and thus insignificant marginal costs associated with bridge use are incurred. This suggests that marginal cost

pricing or any other cost allocation method based on marginal costs may not be appropriate for bridge cost allocation analysis.

The Incremental Method was selected for bridge cost allocation analysis in this research since the capital costs of bridge construction is the dominant element in bridge life-cycle costs. Vehicle characteristics such as gross vehicle weight (GVW) and axle loads influence the bridge costs, not the level of usage and repetition of traffic loadings (Schelling, 1985). The Incremental Method can be used to take into account the capital costs implied by different vehicle characteristics (Tee et al., 1986). The relationships between design vehicle loadings and bridge costs were outlined in the previous chapter.

As described in Chapter 2, in the conventional Incremental Method the distribution of costs between different vehicles is achieved based on the concept of avoidable costs. The method classifies the vehicles into several groups and initially defines a system for withstanding the loadings of basic vehicles (i.e., passenger cars). The method allocates the costs of the basic system to all vehicles in proportion to their share of system usage. In the Incremental Method, the vehicles belonging to the basic vehicle group are only responsible for their share of the costs of the basic system. The additional costs of accommodating heavier vehicles are considered escapable costs which could be avoided if those vehicles are excluded from the system. These costs should be allocated to successive vehicle classes. The incremental costs of providing each successive class with the road services should be distributed among all successive classes in proportion to their system usage relative to the overall system usage of remaining vehicles.

In this research, the same user classifications used for the pavement cost allocation analysis are used in order to achieve consistency. Bridge users are categorized into several classes according to vehicle type, payload and the type of road on which they operate. The characteristics of each user class are shown by cells in a cost allocation matrix. Each cell is indexed by i , j , and k which indicate the vehicle class, payload amount and road type, respectively. The Incremental Method used in this analysis evaluates the bridge costs associated with each cell ijk . It considers the cell's

representative vehicle as the design vehicle and applies the Incremental Method to all of those cells.

Figure 7.1 illustrates the analysis framework for bridge cost allocation. The general approach is to calculate the maximum load impact (e.g., critical bending moment in beams) of different cells and relate them to the maximum cost impact of the design vehicle. The cost impact of the actual design vehicle is assumed to be equal to the bridge construction costs estimated by regression equations developed in the previous chapter. As explained in the previous chapter, in Ontario bridges are designed according to the standards suggested by the Ontario Bridge Design Code. The standard bridge loading is represented by a design truck plus a uniformly distributed load. The standard design truck represents the vehicle loadings which have the largest cost impact and can be identified by one of the cells of the bridge cost allocation matrix. The vehicles belonging to that cell create the largest internal forces. It may be assumed that if that cell does not exist, the bridge design loadings could be reduced. This task has been accomplished for each cell assuming that the vehicles in each cell were the critical vehicles in the system. The cost impact of each cell is estimated by using the equations developed by the 1986 Indiana Bridge Cost Study updated to Ontario costs. The critical forces created by different vehicles were calculated and compared with the AASHTO loadings. This helped to estimate the maximum bridge costs for different design loadings by using the bridge cost estimation equation developed by the Indiana study (Equation [6.5]). The results of the Indiana study were modified for conditions in Ontario and were used to estimate the relative cost of bridges for different design loads. The approach was to calculate the critical internal forces created by different vehicles and compare them with the impact of the design vehicle.

The results of the analysis are illustrated in Tables 7.1 to 7.9 along with the percentage usage of the bridge system by different users (P_{ijk}). These results form a three dimensional matrix which will be called the bridge cost allocation matrix through the rest of this thesis.

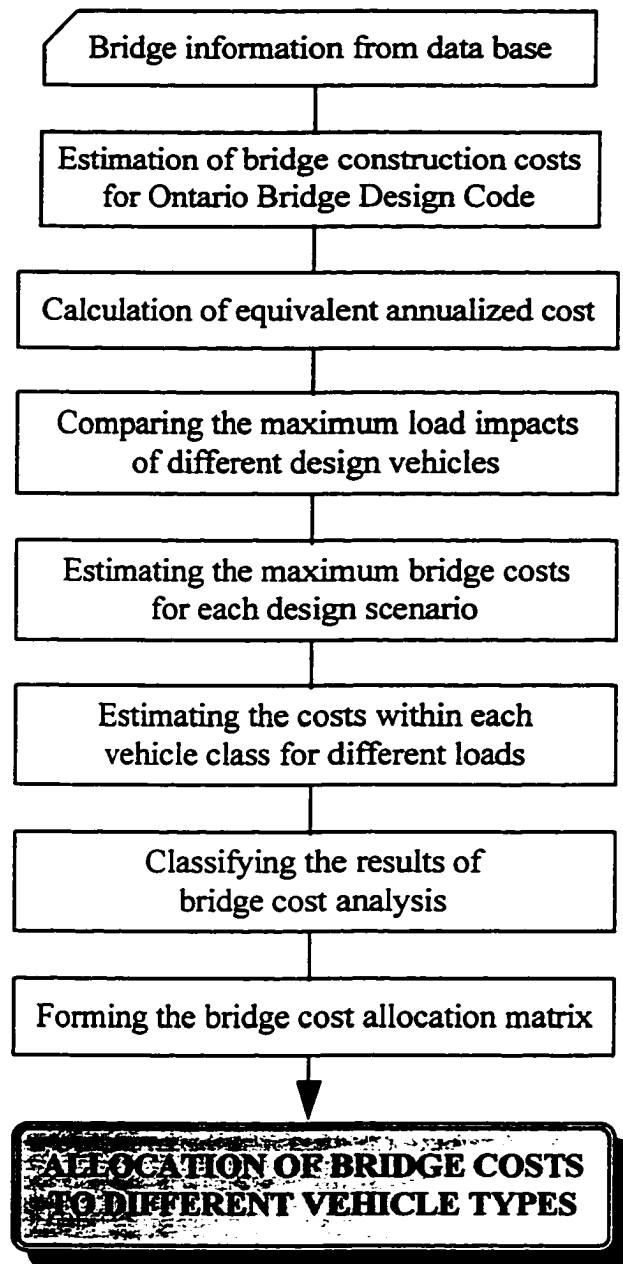

Figure 7.1. Framework of Analysis of Bridge Cost Impacts

Table 7.1. Bridge Cost Matrix, Road Class 1

Vehicle Class		Payload				
		Empty	1-10 t	10-30 t	30-50 t	>50 t
Passenger Cars	Max Cost, \$	425,477				
	P	0.0049				
Tractor + Single to Tridem Semitrailers	Max Cost, \$	539,348	574,687	655,509	752,692	
	P	0.000080	0.000074	0.00011	0.000012	
Tractor + 3 and 4 Axle Semitrailers	Max Cost, \$	556,270	592,074	678,660	758,670	833,068
	P	0.0000059	0.0000053	0.000014	0.0000092	0.0000045
Tractor + 5 or more Axle Semitrailers	Max Cost, \$	562,428	607,263	713,644	776,821	790,821
	P	0.0000011	0.0000014	0.0000076	0.0000020	0.0000008
Heavy Haul A and B-Trains	Max Cost, \$	556,311	595,793	735,142	773,851	812,559
	P	0.0000056	0.0000076	0.0000056	0.000018	0.000015
Tractor + 2 and 3 Axle B-Trains	Max Cost, \$	554,022	590,750	710,113	778,058	792,749
	P	0.0000019	0.0000058	0.0000015	0.0000028	0.0000047
Single Unit Trucks	Max Cost, \$	480,549	513,591	645,762		
	P	0.000062	0.000032	0.000068		
Truck Trailers	Max Cost, \$	556,270	592,074	678,660	758,670	770,768
	P	0.0000029	0.0000015	0.0000021	0.0000017	0.0000010

Table 7.2. Bridge Cost Matrix, Road Class 2

Vehicle Class		Payload				
		Empty	1-10 t	10-30 t	30-50 t	>50 t
Passenger Cars	Max Cost, \$	2,249,733				
	P	0.036				
Tractor + Single to Tridem Semitrailers	Max Cost, \$	2,873,977	3,067,708	3,510,778	3,983,538	
	P	0.0010	0.00094	0.0014	0.00015	
Tractor + 3 and 4 Axle Semitrailers	Max Cost, \$	2,930,656	3,117,054	3,567,833	3,984,375	4,342,234
	P	0.000074	0.000068	0.00018	0.00012	0.0000057
Tractor + 5 or more Axle Semitrailers	Max Cost, \$	2,952,813	3,182,988	3,729,131	4,053,468	4,151,753
	P	0.000014	0.0000018	0.000010	0.000026	0.0000010
Heavy Haul A and B-Trains	Max Cost, \$	2,952,620	3,179,054	3,939,407	4,049,416	4,235,332
	P	0.000071	0.000010	0.000071	0.00023	0.000019
Tractor + 2 and 3 Axle B-Trains	Max Cost, \$	2,930,607	3,115,245	3,717,559	4,117,492	4,195,315
	P	0.000024	0.0000074	0.000019	0.000036	0.0000059
Single Unit Trucks	Max Cost, \$	2,552,872	2,734,756	3,462,289		
	P	0.00078	0.00041	0.000087		
Truck Trailers	Max Cost, \$	2,773,196	2,880,000	3,464,914	3,939,691	4,049,242
	P	0.000037	0.000019	0.000026	0.000022	0.0000013

Table 7.3. Bridge Cost Matrix, Road Class 3

Vehicle Class		Payload				
		Empty	1-10 t	10-30 t	30-50 t	>50 t
Passenger Cars	Max Cost, \$	1,640,680				
	P	0.050				
Tractor + Single to Tridem Semitrailers	Max Cost, \$	2,077,799	2,213,457	2,523,712	2,896,771	
	P	0.0017	0.0015	0.0024	0.00025	
Tractor + 3 and 4 Axle Semitrailers	Max Cost, \$	2,164,732	2,308,187	2,655,115	2,975,694	3,287,740
	P	0.000123	0.000112	0.00029	0.00019	0.0000094
Tractor + 5 or more Axle Semitrailers	Max Cost, \$	2,194,092	2,375,269	2,805,151	3,060,446	3,104,511
	P	0.000023	0.0000029	0.000016	0.000042	0.0000017
Heavy Haul A and B-Trains	Max Cost, \$	2,170,224	2,330,027	2,894,038	3,050,708	3,207,377
	P	0.00012	0.000016	0.00012	0.00038	0.000032
Tractor + 2 and 3 Axle B-Trains	Max Cost, \$	2,159,248	2,307,410	2,788,938	3,063,038	3,122,303
	P	0.000040	0.000012	0.000031	0.000059	0.0000098
Single Unit Trucks	Max Cost, \$	1,842,269	1,963,223	2,447,037		
	P	0.0013	0.00068	0.00014		
Truck Trailers	Max Cost, \$	2,020,121	2,087,879	2,521,526	2,860,313	2,995,828
	P	0.000061	0.000032	0.000043	0.000036	0.0000021

Table 7.4. Bridge Cost Matrix, Road Class 4

Vehicle Class		Payload				
		Empty	1-10 t	10-30 t	30-50 t	>50 t
Passenger Cars	Max Cost, \$	256,056				
	P	0.013				
Tractor + Single to Tridem Semitrailers	Max Cost, \$	324,558	345,817	394,437	452,900	
	P	0.00039	0.00036	0.00055	0.000058	
Tractor + 3 and 4 Axle Semitrailers	Max Cost, \$	336,352	358,333	411,490	460,610	505,861
	P	0.000029	0.000026	0.000069	0.000045	0.0000022
Tractor + 5 or more Axle Semitrailers	Max Cost, \$	339,990	367,469	432,668	471,387	480,347
	P	0.0000053	0.0000069	0.0000037	0.000010	0.0000039
Heavy Haul A and B-Trains	Max Cost, \$	337,815	362,488	449,569	473,758	497,948
	P	0.000027	0.0000037	0.000027	0.000088	0.0000075
Tractor + 2 and 3 Axle B-Trains	Max Cost, \$	335,915	358,732	432,887	475,099	484,225
	P	0.0000094	0.0000028	0.0000074	0.000014	0.0000023
Single Unit Trucks	Max Cost, \$	288,282	307,617	384,960		
	P	0.00030	0.00016	0.000033		
Truck Trailers	Max Cost, \$	315,736	326,393	394,599	447,885	469,199
	P	0.000014	0.0000074	0.000010	0.0000084	0.0000049

Table 7.5. Bridge Cost Matrix, Road Class 5

Vehicle Class		Payload				
		Empty	1-10 t	10-30 t	30-50 t	>50 t
Passenger Cars	Max Cost, \$	355,433				
	P	0.0092				
Tractor + Single to Tridem Semitrailers	Max Cost, \$	449,798	479,084	546,061	626,596	
	P	0.00013	0.00012	0.00018	0.00019	
Tractor + 3 and 4 Axle Semitrailers	Max Cost, \$	466,870	497,375	571,147	639,317	708,308
	P	0.0000095	0.0000086	0.000023	0.000015	0.0000073
Tractor + 5 or more Axle Semitrailers	Max Cost, \$	473,999	512,815	604,916	659,611	666,709
	P	0.0000018	0.0000023	0.0000012	0.0000033	0.0000013
Heavy Haul A and B-Trains	Max Cost, \$	467,838	501,760	621,481	654,737	687,993
	P	0.0000090	0.0000012	0.0000090	0.000029	0.000025
Tractor + 2 and 3 Axle B-Trains	Max Cost, \$	465,476	496,917	599,100	657,265	669,841
	P	0.0000031	0.0000094	0.0000024	0.0000046	0.0000075
Single Unit Trucks	Max Cost, \$	398,997	425,135	529,687		
	P	0.000099	0.000052	0.000011		
Truck Trailers	Max Cost, \$	435,718	450,054	541,808	613,490	642,163
	P	0.0000047	0.0000024	0.0000033	0.0000028	0.0000016

Table 7.6. Bridge Cost Matrix, Road Class 6

Vehicle Class		Payload				
		Empty	1-10 t	10-30 t	30-50 t	>50 t
Passenger Cars	Max Cost, \$	1,826,093				
	P	0.076				
Tractor + Single to Tridem Semitrailers	Max Cost, \$	2,319,377	2,472,465	2,822,583	3,243,576	
	P	0.0011	0.0010	0.0016	0.00017	
Tractor + 3 and 4 Axle Semitrailers	Max Cost, \$	2,384,958	2,537,944	2,907,919	3,249,794	3,568,965
	P	0.000083	0.000076	0.00020	0.00013	0.0000064
Tractor + 5 or more Axle Semitrailers	Max Cost, \$	2,411,698	2,603,414	3,058,304	3,348,449	3,387,169
	P	0.000016	0.0000020	0.000011	0.000029	0.000011
Heavy Haul A and B-Trains	Max Cost, \$	2,404,214	2,578,676	3,194,426	3,325,468	3,486,509
	P	0.000079	0.000011	0.000079	0.00026	0.000022
Tractor + 2 and 3 Axle B-Trains	Max Cost, \$	2,384,865	2,537,286	3,054,703	3,330,371	3,424,300
	P	0.000027	0.0000083	0.000021	0.000040	0.0000066
Single Unit Trucks	Max Cost, \$	2,064,290	2,207,208	2,778,879		
	P	0.00088	0.00046	0.000097		
Truck Trailers	Max Cost, \$	2,253,735	2,330,099	2,818,833	3,190,656	3,313,385
	P	0.000042	0.000022	0.000029	0.000024	0.0000014

Table 7.7. Bridge Cost Matrix, Road Class 7

Vehicle Class		Payload				
		Empty	1-10 t	10-30 t	30-50 t	>50 t
Passenger Cars	Max Cost, \$	2,759,943				
	P	0.16				
Tractor + Single to Tridem Semitrailers	Max Cost, \$	3,495,233	3,723,426	4,245,313	4,872,845	
	P	0.0032	0.0029	0.0045	0.00047	
Tractor + 3 and 4 Axle Semitrailers	Max Cost, \$	3,649,812	3,893,408	4,482,512	5,026,873	5,592,047
	P	0.00023	0.00021	0.00056	0.00037	0.000018
Tractor + 5 or more Axle Semitrailers	Max Cost, \$	3,711,530	4,023,061	4,762,241	5,201,217	5,245,612
	P	0.000043	0.0000056	0.000030	0.000080	0.0000032
Heavy Haul A and B-Trains	Max Cost, \$	3,657,156	3,927,913	4,883,524	5,148,972	5,414,419
	P	0.00022	0.000030	0.00022	0.00071	0.000060
Tractor + 2 and 3 Axle B-Trains	Max Cost, \$	3,640,967	3,892,688	4,710,782	5,176,466	5,277,155
	P	0.000076	0.000023	0.000060	0.00011	0.000018
Single Unit Trucks	Max Cost, \$	3,091,771	3,290,868	4,087,256		
	P	0.0024	0.0013	0.00027		
Truck Trailers	Max Cost, \$	3,394,851	3,508,227	4,233,837	4,800,719	5,027,472
	P	0.00012	0.000060	0.000081	0.000068	0.0000040

Table 7.8. Bridge Cost Matrix, Road Class 8

Vehicle Class		Payload				
		Empty	1-10 t	10-30 t	30-50 t	>50 t
Passenger Cars	Max Cost, \$	1,860,757				
	P	0.16				
Tractor + Single to Tridem Semitrailers	Max Cost, \$	2,353,959	2,507,021	2,857,081	3,278,003	
	P	0.0048	0.0044	0.0068	0.00070	
Tractor + 3 and 4 Axle Semitrailers	Max Cost, \$	2,459,807	2,623,792	3,020,369	3,386,827	3,780,584
	P	0.00035	0.00032	0.00084	0.00055	0.000027
Tractor + 5 or more Axle Semitrailers	Max Cost, \$	2,505,819	2,717,000	3,218,075	3,515,648	3,534,079
	P	0.000065	0.0000084	0.000046	0.00012	0.0000048
Heavy Haul A and B-Trains	Max Cost, \$	2,463,301	2,645,134	3,286,896	3,465,164	3,643,431
	P	0.00033	0.000046	0.00033	0.0011	0.000091
Tractor + 2 and 3 Axle B-Trains	Max Cost, \$	2,452,539	2,621,620	3,171,131	3,483,930	3,551,562
	P	0.00012	0.000035	0.000090	0.00017	0.000028
Single Unit Trucks	Max Cost, \$	2,082,228	2,215,111	2,746,641		
	P	0.0037	0.0019	0.00041		
Truck Trailers	Max Cost, \$	2,282,956	2,358,349	2,840,862	3,217,826	3,368,611
	P	0.00018	0.000091	0.00012	0.00010	0.0000060

Table 7.9. Bridge Cost Matrix, Road Class 9

Vehicle Class		Payload				
		Empty	1-10 t	10-30 t	30-50 t	>50 t
Passenger Cars	Max Cost, \$	2,295,383				
	P	0.36				
Tractor + Single to Tridem Semitrailers	Max Cost, \$	2,912,673	3,104,246	3,542,380	4,069,206	
	P	0.011	0.0098	0.015	0.0016	
Tractor + 3 and 4 Axle Semitrailers	Max Cost, \$	3,006,343	3,200,963	3,671,626	4,106,542	4,497,898
	P	0.00078	0.00071	0.0019	0.0012	0.000060
Tractor + 5 or more Axle Semitrailers	Max Cost, \$	3,035,428	3,277,705	3,852,562	4,193,951	4,281,303
	P	0.00014	0.000019	0.00010	0.00027	0.000011
Heavy Haul A and B-Trains	Max Cost, \$	3,026,216	3,246,763	4,025,164	4,241,387	4,457,610
	P	0.00074	0.00010	0.00074	0.0024	0.00020
Tractor + 2 and 3 Axle B-Trains	Max Cost, \$	3,003,386	3,205,673	3,863,105	4,237,335	4,318,249
	P	0.00026	0.00008	0.00020	0.00037	0.00006
Single Unit Trucks	Max Cost, \$	2,592,241	2,770,356	3,482,814		
	P	0.0082	0.0043	0.00091		
Truck Trailers	Max Cost, \$	2,836,630	2,933,281	3,551,848	4,035,103	4,228,406
	P	0.00039	0.00020	0.00027	0.00023	0.000013

The table entries imply that heavy semitrailers with a low number of axles (Vehicle Type 3) control the design of the bridges. For example, Table 7.1 shows that over \$833,000 is spent on bridges (for those in the analysis database) on low volume roads in Northern Ontario (Road Class 1). The table also shows that if Type 3 vehicles did not exist on those low volume roads in Northern Ontario then Type 6 vehicles would control the bridge design and lower construction costs (roughly \$813,000) would be required. Based on the Incremental Method, Type 3 vehicles are responsible for all of the \$20,000 difference between these two design vehicle scenarios.

Similar interpretations can be made for the other design vehicle scenarios within each layer of the bridge cost allocation matrix. The minimum bridge costs are related to passenger cars (Vehicle Class 1) which are responsible for about 50 percent of the actual bridge cost.

It must be noted that bridge and pavement information are taken from two separate databases. This may create problems concerning the geographic scales associated with the roads in the two databases, especially since the proportion of usage for users in matrix cells are obtained from the pavement cost allocation analysis. Therefore, in order to be able to compare the entries of the pavement and bridge cost allocation matrices, the cost entries of the bridge matrix should be adjusted so that they represent the bridge costs for the users of the same geographic area as represented by the pavement matrix. In this regard bridge costs were adjusted to 14 percent of the pavement costs according to information obtained from the Structural Office at the Ministry of Transportation Ontario (MTO).

7.3. FORMULATION OF THE PROBLEM

To formulate the incremental cost allocation procedure for this research, the cells within each road group were ranked according to their bridge cost attributes. The bridge costs were partitioned into different increments. All the vehicles were assumed to be responsible for the first increment in proportion to their usage as if they all had the same configuration. Passenger cars were then taken out of the system and the additional cost of accommodating heavier vehicles was incrementally assigned based on a similar procedure as for the basic system. The system, consisting of heavier vehicles, was considered as a new system and an attempt was made to evaluate the minimum system costs for accommodating the smallest vehicles of the group and assigning those costs to all users. These costs were incrementally assigned to heavier vehicles.

Each successive incremental vehicle class shares in the costs of providing facilities necessary for vehicles smaller than it. Therefore, assuming that the cells within each matrix layer (representing road type) are ranked based on their maximum bridge cost attributes and labelled R according to their rank, the problem can be formulated by Equations [7.1] and [7.2].

$$T^R = \sum_{i=1..R} c^i \quad [7.1]$$

where,

$$c^i = \frac{MAXCOST^i}{\sum_{j=i..33} P^j \times D} \quad [7.2]$$

T^R = price/km allocated to each vehicle with rank R ,

$MAXCOST^i$ = bridge cost of cell with rank i if it represented the design vehicles and these are directly taken from the bridge cost allocation matrices,

D = total kilometres of operation in the system, and

$P^j = \sum_i P_{ijk}$ = proportion of the use of the system by each vehicle type.

Superscript R indicates the rank of the vehicle type according to their bridge cost implications for each road type. For example, $R=1$ indicates the cell with the minimum cost impact and $R=33$ indicates the cell with the greatest cost impact. Each R corresponds to only one cell for each road type.

Based on the above formulation an incremental cost allocation analysis has been applied to bridge costs in Ontario and the results are illustrated in Tables 7.10 to 7.18. For example, for Road Class 1 passenger cars (Vehicle Class 1) should pay the minimum charge (\$0.0066 /km) in order to recover the annualized cost of bridges in Ontario. There is an extra charge associated with other vehicles with higher cost implications. For example, a standard 5-axle tractor semitrailer (Vehicle Class 4) in the 10-30 t payload range should be charged \$0.156 /km. In general, the allocated user charges increase as the impact of vehicle on bridge cost increases. Some cost entries are for vehicles with over legal load. These prices are significantly higher compared to the other prices. This is because overloaded vehicles create critical loadings and bridge design standards are established to withstand such forces with appropriate safety factors. Also, a small percentage of road users are usually responsible for the cost implications of such critical forces and this leads to high prices assigned to those vehicles.

Table 7.10. User Charges (\$/km) for Bridges, Road Class 1

Vehicle Class	Payload				
	Empty	1-10 t	10-30 t	30-50 t	>50 t
Passenger Cars	0.0066				
Single to Tridem Semitrailers	0.029	0.040	0.076	0.222	
3 and 4 axle Semitrailers	0.034	0.047	0.103	0.236	23.463
5+ axle Semitrailers	0.036	0.054	0.156	0.321	0.767
Heavy Haul A and B-Trains	0.034	0.049	0.190	0.287	1.888
2 and 3 axle B-Trains	0.034	0.047	0.151	0.340	0.846
Single Unit Trucks	0.017	0.024	0.071		
Truck Trailers	0.026	0.029	0.073	0.192	0.277

Table 7.11. User Charges (\$/km) for Bridges, Road Class 2

Vehicle Class	Payload				
	Empty	1-10 t	10-30 t	30-50 t	>50 t
Passenger Cars	0.0046				
Single to Tridem Semitrailers	0.014	0.019	0.034	0.091	
3 and 4 axle Semitrailers	0.016	0.021	0.040	0.091	9.45
5+ axle Semitrailers	0.016	0.023	0.059	0.11	0.28
Heavy Haul A and B-Trains	0.016	0.023	0.085	0.11	0.59
2 and 3 axle B-Trains	0.016	0.021	0.058	0.19	0.42
Single Unit Trucks	0.0089	0.012	0.033		
Truck Trailers	0.013	0.015	0.033	0.085	0.11

Table 7.12. User Charges (\$/km) for Bridges, Road Class 3

Vehicle Class	Payload				
	Empty	1-10 t	10-30 t	30-50 t	>50 t
Passenger Cars	0.0023				
Single to Tridem Semitrailers	0.0065	0.0085	0.015	0.040	
3 and 4 axle Semitrailers	0.0078	0.010	0.023	0.050	4.43
5+ axle Semitrailers	0.0082	0.012	0.033	0.067	0.14
Heavy Haul A and B-Trains	0.0078	0.011	0.040	0.061	0.38
2 and 3 axle B-Trains	0.0077	0.010	0.032	0.069	0.17
Single Unit Trucks	0.0041	0.0053	0.013		
Truck Trailers	0.0059	0.0067	0.015	0.038	0.053

Table 7.13. User Charges (\$/km) for Bridges, Road Class 4

Vehicle Class	Payload				
	Empty	1-10 t	10-30 t	30-50 t	>50 t
Passenger Cars	0.0014				
Single to Tridem Semitrailers	0.0043	0.0056	0.010	0.027	
3 and 4 axle Semitrailers	0.0050	0.0066	0.014	0.031	1.96
5+ axle Semitrailers	0.0052	0.0075	0.021	0.038	0.080
Heavy Haul A and B-Trains	0.0050	0.0070	0.026	0.040	0.26
2 and 3 axle B-Trains	0.0049	0.0067	0.021	0.044	0.11
Single Unit Trucks	0.0026	0.0035	0.0090		
Truck Trailers	0.0038	0.0044	0.010	0.025	0.037

Table 7.14. User Charges (\$/km) for Bridges, Road Class 5

Vehicle Class	Payload				
	Empty	1-10 t	10-30 t	30-50 t	>50 t
Passenger Cars	0.0030				
Single to Tridem Semitrailers	0.015	0.020	0.038	0.11	
3 and 4 axle Semitrailers	0.018	0.025	0.057	0.13	14.26
5+ axle Semitrailers	0.019	0.029	0.089	0.21	0.35
Heavy Haul A and B-Trains	0.018	0.026	0.11	0.16	1.02
2 and 3 axle B-Trains	0.018	0.025	0.083	0.18	0.43
Single Unit Trucks	0.0079	0.011	0.034		
Truck Trailers	0.013	0.015	0.037	0.097	0.14

Table 7.15. User Charges (\$/km) for Bridges, Road Class 6

Vehicle Class	Payload				
	Empty	1-10 t	10-30 t	30-50 t	>50 t
Passenger Cars	0.0019				
Single to Tridem Semitrailers	0.0088	0.012	0.023	0.067	
3 and 4 axle Semitrailers	0.010	0.014	0.030	0.068	6.64
5+ axle Semitrailers	0.011	0.016	0.046	0.11	0.20
Heavy Haul A and B-Trains	0.011	0.015	0.061	0.086	0.54
2 and 3 axle B-Trains	0.010	0.014	0.046	0.090	0.31
Single Unit Trucks	0.0049	0.0070	0.021		
Truck Trailers	0.0077	0.0090	0.023	0.061	0.083

Table 7.16. User Charges (\$/km) for Bridges, Road Class 7

Vehicle Class	Payload				
	Empty	1-10 t	10-30 t	30-50 t	>50 t
Passenger Cars	0.0013				
Single to Tridem Semitrailers	0.0050	0.0067	0.013	0.035	
3 and 4 axle Semitrailers	0.0062	0.0086	0.020	0.044	5.04
5+ axle Semitrailers	0.0067	0.010	0.030	0.074	0.11
Heavy Haul A and B-Trains	0.0062	0.0089	0.035	0.054	0.33
2 and 3 axle B-Trains	0.0061	0.0086	0.028	0.062	0.14
Single Unit Trucks	0.0028	0.0038	0.011		
Truck Trailers	0.0044	0.0051	0.012	0.032	0.044

Table 7.17. User Charges (\$/km) for Bridges, Road Class 8

Vehicle Class	Payload				
	Empty	1-10 t	10-30 t	30-50 t	>50 t
Passenger Cars	0.00085				
Single to Tridem Semitrailers	0.0025	0.0033	0.0058	0.016	
3 and 4 axle Semitrailers	0.0030	0.0041	0.0091	0.020	2.55
5+ axle Semitrailers	0.0033	0.0048	0.014	0.038	0.048
Heavy Haul A and B-Trains	0.0031	0.0043	0.016	0.024	0.14
2 and 3 axle B-Trains	0.0030	0.0041	0.013	0.028	0.060
Single Unit Trucks	0.0015	0.0020	0.0050		
Truck Trailers	0.0022	0.0025	0.0057	0.014	0.019

Table 7.18. User Charges (\$/km) for Bridges, Road Class 9

Vehicle Class	Payload				
	Empty	1-10 t	10-30 t	30-50 t	>50 t
Passenger Cars	0.00046				
Single to Tridem Semitrailers	0.0014	0.0018	0.0033	0.0091	
3 and 4 axle Semitrailers	0.0016	0.0021	0.0044	0.010	0.41
5+ axle Semitrailers	0.0017	0.0024	0.0065	0.012	0.023
Heavy Haul A and B-Trains	0.0016	0.0023	0.0085	0.013	0.090
2 and 3 axle B-Trains	0.0016	0.0022	0.0066	0.013	0.035
Single Unit Trucks	0.00087	0.0011	0.0031		
Truck Trailers	0.0013	0.0014	0.0034	0.0087	0.013

It can be observed from the tables that the maximum charges are associated with Vehicle Class 3 loaded with payloads over 50 t. Those vehicles should be charged significantly higher than the other vehicles for two reasons: *i*) they incur the highest bridge costs, and *ii*) the last incremental cost would be collected from a small group of users. The bridge cost allocation analysis has resulted in a wide range of prices associated with different classes of road users in Ontario. To develop a general idea about the overall relationship between the bridge charges, prices are averaged for Northern and Southern Ontario and are shown in Tables 7.19 and 7.20.

Table 7.19. Average User Charges (\$/km) for Bridges, Northern Ontario

Vehicle Class	Payload				
	Empty	1-10 t	10-30 t	30-50 t	>50 t
Passenger Cars	0.003				
Single to Tridem Semitrailers	0.009	0.012	0.022	0.060	
3 and 4 axle Semitrailers	0.011	0.014	0.029	0.065	6.215
5+ axle Semitrailers	0.011	0.016	0.043	0.084	0.191
Heavy Haul A and B-Trains	0.011	0.015	0.057	0.080	0.472
2 and 3 axle B-Trains	0.011	0.014	0.042	0.112	0.261
Single Unit Trucks	0.006	0.008	0.020		
Truck Trailers	0.008	0.010	0.022	0.055	0.074

Table 7.20. Average User Charges (\$/km) for Bridges, Southern Ontario

Vehicle Class	Payload				
	Empty	1-10 t	10-30 t	30-50 t	>50 t
Passenger Cars	0.001				
Single to Tridem Semitrailers	0.003	0.004	0.007	0.019	
3 and 4 axle Semitrailers	0.003	0.004	0.010	0.022	2.115
5+ axle Semitrailers	0.003	0.005	0.015	0.035	0.056
Heavy Haul A and B-Trains	0.003	0.005	0.018	0.028	0.172
2 and 3 axle B-Trains	0.003	0.004	0.014	0.030	0.077
Single Unit Trucks	0.002	0.002	0.006		
Truck Trailers	0.002	0.003	0.007	0.017	0.024

Tables 7.19 and 7.20 imply that based on the Incremental Method, the suggested bridge price in Northern Ontario should be roughly three times higher than those in Southern Ontario. This may be justified by the fact that there is a larger number of road users in Southern Ontario compared to Northern Ontario.

The differences in prices are illustrated in Figure 7.2. Bridge user fees increase with a significant increasing rate as the vehicle loadings increase. For example, vehicles with a payload of about 50 t should pay about \$0.35 /km and \$0.12 /km in Northern and Southern Ontario respectively, while these fees would be about \$0.04 /km and \$0.01 /km for vehicles with half that payload (25 t). The sharp increase in bridge prices for payloads over 40 t reflects the penalties attributed to overloaded vehicles as explained in the previous paragraphs.

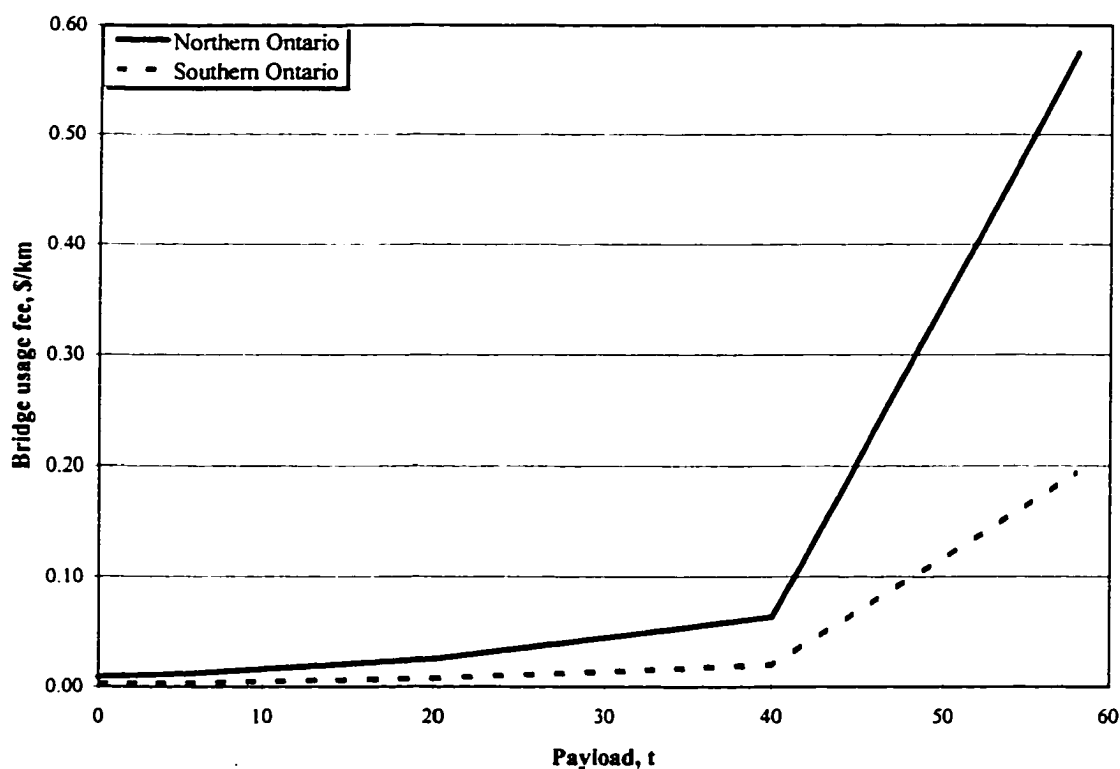

Figure 7.2. Bridge Usage Fees vs Payload

The economic and policy implications of the cost allocation results are discussed in more detail in the next chapter. In general, the incremental cost allocation analysis of bridges is a completely different approach than the game-theoretic cost allocation analysis applied to pavements. Since the total bridge costs are about 14 percent of pavement costs in Ontario, it may be assumed that in the event of implementation of a charging system (and if the results of bridge cost allocation analysis have to be merged with those of pavements) the pavement cost allocation results will play a dominant role in the road charging structure.

CHAPTER 8

Optimal Road Pricing

8.1. INTRODUCTION

The cost allocation analysis accomplished in this research classified road users into groups and calculated a wide range of prices to different user classes. Such a pricing schedule is not impossible to implement but may be costly and difficult to manage. As an alternative, estimated prices can be simplified for several road user classes to reflect the average cost responsibility of those classes together. A complex pricing system may lead to efficient use of the system by directing road users to select optimal vehicle configurations and payload amounts. Efficient behaviour by users could decrease the rate of infrastructure deterioration and result in savings on total system costs (Lee, 1982). If the savings on road damage costs exceed the administrative costs of a complex pricing scheme, implementation of that pricing system is justified for road authorities. Otherwise the pricing system should be simplified to the point that it becomes justified using ideal results as a firm basis for the design of a practical charging scheme.

Analyzing the effect of different pricing schemes on system performance requires a great amount of information about the sensitivity and reaction of the users to prices, the structure of the demand and supply in the market and vehicle functional characteristics.

This is clearly beyond the scope of this research. However, an attempt has been made in this chapter to analyze the above issues in order to arrive at new research dimensions for evaluating the road charging system and to provide suggestions about the characteristics of a sound pricing scheme for the Ontario intercity highway network.

8.2. CHARGING SYSTEM CHARACTERISTICS

As explained in Chapter 2, different factors influence the efficiency of a road taxation system. Some of the factors are noteworthy at the analysis stage (e.g., equity and efficiency issues and characteristics of cost elements). Others are influential in practice and are associated with the charging instruments. It is important to know how different participants of the road system recognize those issues. For example, road users and a road agency are likely to have conflicting views about certain issues in road pricing. This may affect the behaviour of road users in terms of the selection of vehicles or payload weight.

One of the arguments between automobile users and truck users comes from the significant differences between the damage created by each group. Automobile users may expect a much lower tax since their operation on the system may not have significant cost implications. This is the most important justification for small vehicles to demand a decrease in their share of highway costs. On the other hand, the trucking industry argues that the low damage effects associated with small vehicles come from the fact that highways are designed to withstand truck loads. They also point to the fact that the size of the road network in terms of pavement width and the number of lanes is mainly influenced by passenger cars which create most of the traffic in the system. They assume that if the road network were built only for trucks, the infrastructure costs would be lower since the number of lanes on multi-lane highways could be reduced in most cases. Therefore, the trucking industry believes that pricing according to the marginal costs of different vehicles is not appropriate.

Analyses have been carried out in this chapter to find out the overall cost of pavements if they were used by different users separately. To accomplish this task a computer program has been developed that redesigns the whole system for each scenario and calculates the corresponding present value of the 30-year life cycle costs of roads. The road design specifications for each scenario are specified considering both traffic and vehicle loading situations. The number of lanes of each road section is specified based on the traffic situation of the link and pavement thicknesses are calculated based on the repetition of axle loadings on each lane.

Table 8.1 illustrates the present worth of total life-cycle costs for the Ontario highway system for different vehicle scenarios. The entries in column 2 show the road costs for a road system with the same number of road lanes as the current system. The entries in column 3 represent the present worth life-cycle costs of the system when the number of lanes are adjusted to fulfill the demand for the traffic created by different road users. There would be reductions in the number of lanes for many road sections if passenger cars did not exist in the system. The entries in column 3 represent the combined effect of higher infrastructure costs and savings in initial pavement costs from fewer lanes.

Table 8.1. Road Life-Cycle Costs for Different Vehicle Scenarios, Billion \$

Scenario	Number of Lanes Not Adjusted	Number of Lanes Adjusted
Existing System	2.18	2.18
Cars Alone	1.38	1.38
Trucks Alone	2.18	2.29
Vehicle Class 2 Alone	1.83	1.86
Vehicle Class 3 Alone	1.45	1.50
Vehicle Class 4 Alone	1.21	1.29
Vehicle Class 5 Alone	1.35	1.36
Vehicle Class 6 Alone	1.18	1.19
Vehicle Class 7 Alone	1.27	1.28

The first entry in column 2 shows that the present value of life-cycle costs is \$2.18 billion for the road sections in the analysis database. The second entry in column 2 shows the present value of life-cycle costs for a highway system designed to be used only by passenger cars, where the present worth would be \$1.38 billion. The corresponding entry in column 3 carries the same cost, indicating that there would be no reduction in lane capacity if trucks did not use the system.

It may be concluded from the results of the above analysis that if trucks were out of the system, passenger cars would require more than 60 percent of the cost of the existing network. This reinforces the argument by the trucking industry that the overall damage caused by passenger cars in the existing system is insignificant because the system is designed to withstand heavier loads and the fact that a significant part of the cost is fixed regardless of use. This would also validate the point of view of truck owners who argue against allocating higher road fees associated with trucks just because trucks are more damaging.

Since most of the traffic is generated by passenger cars, the number of lanes required for serving truck traffic would be less than that required for passenger car traffic. This has raised concerns by the trucking industry. They argue they should not be charged for the extra number of lanes required to handle automobile traffic. Table 8.1 suggests that this may not be a valid point because even when trucks are alone in the system, the total costs of the system not only would not decrease but would increase slightly if the number of lanes of multi-lane highways were reduced. If trucks were the only users of the road system, the present value of life-cycle costs would be \$2.18 billion for the existing system. If the number of lanes were reduced as a result of a reduction in traffic, the actual life-cycle costs would increase to \$2.29 billion, while there would be some savings in the initial capital costs of building roads. There would be increases in pavement maintenance and rehabilitation works if all of the trucks were to operate on only one lane or a limited number of lanes.

It may be concluded that by setting road prices according to the damage implication of different vehicles, passenger cars would benefit because they do not

impose significant damage. Since passenger cars incur much more cost when they did not share the same roads with trucks, setting the prices according to the damage caused by different vehicles may result in unfair cost allocation and may be considered as subsidization of automobiles by trucks. It may be concluded that similar relationship as between automobiles and trucks may exist between lighter and heavier trucks.

8.3. CHARGING PRINCIPLES

One difficulty associated with the choice of charging instruments is the inability to relate the user charges to the time and place where the usage takes place. To tackle this problem road authorities usually use a mixture of charging instruments to collect road user charges in order to achieve a higher level of equity and efficiency in the charging system. However, the greater the combination of charging instruments, the larger the expenditures required for administration. It is usually suggested that a number of charging instruments must be selected and combined so that there would be some charges related to the marginal costs of road use and some charges related to the fixed costs of the road system. In the case of trucks, taxes must properly account for differences in axle weights and other truck characteristics which affect road damage costs such as axle spacing.

In practice the charging systems usually utilize a multi-part tariff pricing for each class of vehicle using different road services. They consist of: *i*) vehicle purchase taxes to recover the capital expenditures for construction and major investment in the road infrastructure, *ii*) annual registration fees to recover the expenditures required each year, *iii*) distance taxes (fuel tax) for recovering variable costs associated with the distance driven by each vehicle, and *iv*) tonne-kilometre charges for heavy vehicles that impose significant damage on the system.

The effectiveness of each of the above charging methods depends on many factors including vehicle operating costs, enforcement and level of control of the charging

system, and road prices. The rest of this chapter seeks to discover the influence of prices on user behaviour and system efficiency.

8.4. IMPLEMENTATION OF A SOUND CHARGING SYSTEM IN ONTARIO

8.4.1. Theoretical Charges

The game-theoretic cost allocation analysis in this research classifies the road users into about 300 functional classes (8 types of vehicles, 9 types of roads and 5 groups of payloads). This implies that a truck could use up to 9 differently priced pavement segments and may be charged up to 45 different prices depending on payload and the road type on which it operates. To achieve this a complex set of pricing rules should be implemented. Such a scheme would require high administration costs and a complex set of rules, which should be estimated and justified before implementation.

To establish sound recommendations for the implementation of a better charging system for the Ontario road network, the sensitivity of road users to different pricing mechanisms should be analyzed. Different charging methods should be compared with the ideal charging scheme.

Firstly, the user prices of pavements and bridges are merged together to arrive at a total theoretical charge associated with each user class. These charges are considered to be the ones which would result in maximum efficiency in the utilization of the road system. They are also equitable and admissible for all road users. The theoretical pavement and bridge user charges, estimated before, have been summed together and are summarized in Tables 8.2 to 8.10. The product of these user charges and vehicle use by class would yield the annualized cost of maintaining and rehabilitating the system. The tables show the monetary responsibility of Ontario road users per kilometre of usage. For example, B-trains operating on low volume roads in Northern Ontario (Road Type 1) are assigned a \$0.11/km fee when they carry up to 10 t payload. The entries in the tables reveal a wide variation in prices assigned to different road users. The tables also show that in most cases prices assigned to the road users with vehicles with similar characteristics in Northern Ontario are higher than those in Southern Ontario.

Table 8.2. Road User Charges (\$/km), Road Class 1

Vehicle Class	Payload				
	Empty	1-10 t	10-30 t	30-50 t	>50 t
Passenger Cars	0.076				
Single to Tridem Semitrailers	0.60	0.092	0.22	0.90	
3 and 4 axle Semitrailers	1.57	0.12	0.33	2.43	26.91
5+ axle Semitrailers	1.57	0.12	0.32	0.97	1.95
Heavy Haul A and B-Trains	1.27	0.11	0.35	0.68	2.62
2 and 3 axle B-Trains	1.56	0.11	0.30	0.95	1.89
Single Unit Trucks	0.56	0.066	3.39		
Truck Trailers	0.57	0.046	0.22	2.38	3.80

Table 8.3. Road User Charges (\$/km), Road Class 2

Vehicle Class	Payload				
	Empty	1-10 t	10-30 t	30-50 t	>50 t
Passenger Cars	0.055				
Single to Tridem Semitrailers	0.42	0.034	0.08	0.41	
3 and 4 axle Semitrailers	1.14	0.04	0.11	0.67	10.37
5+ axle Semitrailers	1.15	0.04	0.11	0.42	0.79
Heavy Haul A and B-Trains	0.98	0.04	0.13	0.23	0.80
2 and 3 axle B-Trains	1.14	0.04	0.10	0.49	0.89
Single Unit Trucks	0.10	0.024	0.20		
Truck Trailers	0.41	0.019	0.08	0.67	1.06

Table 8.4. Road User Charges (\$/km), Road Class 3

Vehicle Class	Payload				
	Empty	1-10 t	10-30 t	30-50 t	>50 t
Passenger Cars	0.030				
Single to Tridem Semitrailers	0.20	0.014	0.03	0.25	
3 and 4 axle Semitrailers	0.39	0.018	0.11	0.31	4.83
5+ axle Semitrailers	0.39	0.019	0.050	0.27	0.45
Heavy Haul A and B-Trains	0.39	0.017	0.056	0.15	0.53
2 and 3 axle B-Trains	0.39	0.017	0.048	0.27	0.47
Single Unit Trucks	0.032	0.0097	0.14		
Truck Trailers	0.19	0.0084	0.030	0.30	0.47

Table 8.5. Road User Charges (\$/km), Road Class 4

Vehicle Class	Payload				
	Empty	1-10 t	10-30 t	30-50 t	>50 t
Passenger Cars	0.018				
Single to Tridem Semitrailers	0.037	0.0080	0.087	0.19	
3 and 4 axle Semitrailers	0.038	0.010	0.099	0.27	2.31
5+ axle Semitrailers	0.039	0.011	0.099	0.20	0.41
Heavy Haul A and B-Trains	0.038	0.0098	0.104	0.20	0.51
2 and 3 axle B-Trains	0.038	0.0096	0.10	0.20	0.43
Single Unit Trucks	0.022	0.0055	0.11		
Truck Trailers	0.035	0.0052	0.017	0.26	0.39

Table 8.6. Road User Charges (\$/km), Road Class 5

Vehicle Class	Payload				
	Empty	1-10 t	10-30 t	30-50 t	>50 t
Passenger Cars	0.11				
Single to Tridem Semitrailers	0.88	0.080	0.21	0.67	
3 and 4 axle Semitrailers	3.35	0.11	0.31	1.84	17.10
5+ axle Semitrailers	3.35	0.11	0.28	0.73	1.40
Heavy Haul A and B-Trains	1.85	0.094	0.29	0.62	1.87
2 and 3 axle B-Trains	3.34	0.095	0.26	0.65	1.32
Single Unit Trucks	0.84	0.060	0.70		
Truck Trailers	0.84	0.034	0.20	1.80	3.07

Table 8.7. Road User Charges (\$/km), Road Class 6

Vehicle Class	Payload				
	Empty	1-10 t	10-30 t	30-50 t	>50 t
Passenger Cars	0.021				
Single to Tridem Semitrailers	0.27	0.025	0.059	0.19	
3 and 4 axle Semitrailers	1.00	0.032	0.23	0.54	7.39
5+ axle Semitrailers	1.00	0.033	0.086	0.23	0.44
Heavy Haul A and B-Trains	0.57	0.030	0.100	0.18	0.72
2 and 3 axle B-Trains	1.00	0.029	0.08	0.20	0.51
Single Unit Trucks	0.09	0.017	0.31		
Truck Trailers	0.26	0.013	0.059	0.52	0.86

Table 8.8. Road User Charges (\$/km), Road Class 7

Vehicle Class	Payload				
	Empty	1-10 t	10-30 t	30-50 t	>50 t
Passenger Cars	0.015				
Single to Tridem Semitrailers	0.15	0.012	0.026	0.28	
3 and 4 axle Semitrailers	0.16	0.015	0.16	0.37	5.53
5+ axle Semitrailers	0.16	0.016	0.046	0.32	0.47
Heavy Haul A and B-Trains	0.15	0.014	0.050	0.27	0.64
2 and 3 axle B-Trains	0.15	0.014	0.042	0.30	0.49
Single Unit Trucks	0.026	0.0078	0.18		
Truck Trailers	0.15	0.0067	0.026	0.36	0.55

Table 8.9. Road User Charges (\$/km), Road Class 8

Vehicle Class	Payload				
	Empty	1-10 t	10-30 t	30-50 t	>50 t
Passenger Cars	0.011				
Single to Tridem Semitrailers	0.023	0.0056	0.013	0.20	
3 and 4 axle Semitrailers	0.053	0.0074	0.029	0.28	2.92
5+ axle Semitrailers	0.054	0.0079	0.022	0.22	0.35
Heavy Haul A and B-Trains	0.053	0.0070	0.023	0.20	0.44
2 and 3 axle B-Trains	0.053	0.0069	0.020	0.21	0.36
Single Unit Trucks	0.020	0.0039	0.072		
Truck Trailers	0.021	0.0033	0.012	0.27	0.40

Table 8.10. Road User Charges (\$/km), Road Class 9

Vehicle Class	Payload				
	Empty	1-10 t	10-30 t	30-50 t	>50 t
Passenger Cars	0.0056				
Single to Tridem Semitrailers	0.014	0.0037	0.0093	0.099	
3 and 4 axle Semitrailers	0.035	0.0045	0.012	0.15	0.59
5+ axle Semitrailers	0.035	0.0047	0.013	0.10	0.17
Heavy Haul A and B-Trains	0.035	0.0043	0.015	0.10	0.23
2 and 3 axle B-Trains	0.035	0.0042	0.013	0.10	0.19
Single Unit Trucks	0.010	0.0021	0.019		
Truck Trailers	0.010	0.0018	0.0067	0.14	0.21

Figure 8.1 illustrates the road fees averaged for different road classes in Northern and Southern Ontario. The figure shows that road prices increase exponentially as the vehicle payload increases. At empty or very light loads fees are relatively high because of the inefficiency created by the operation of empty vehicles.

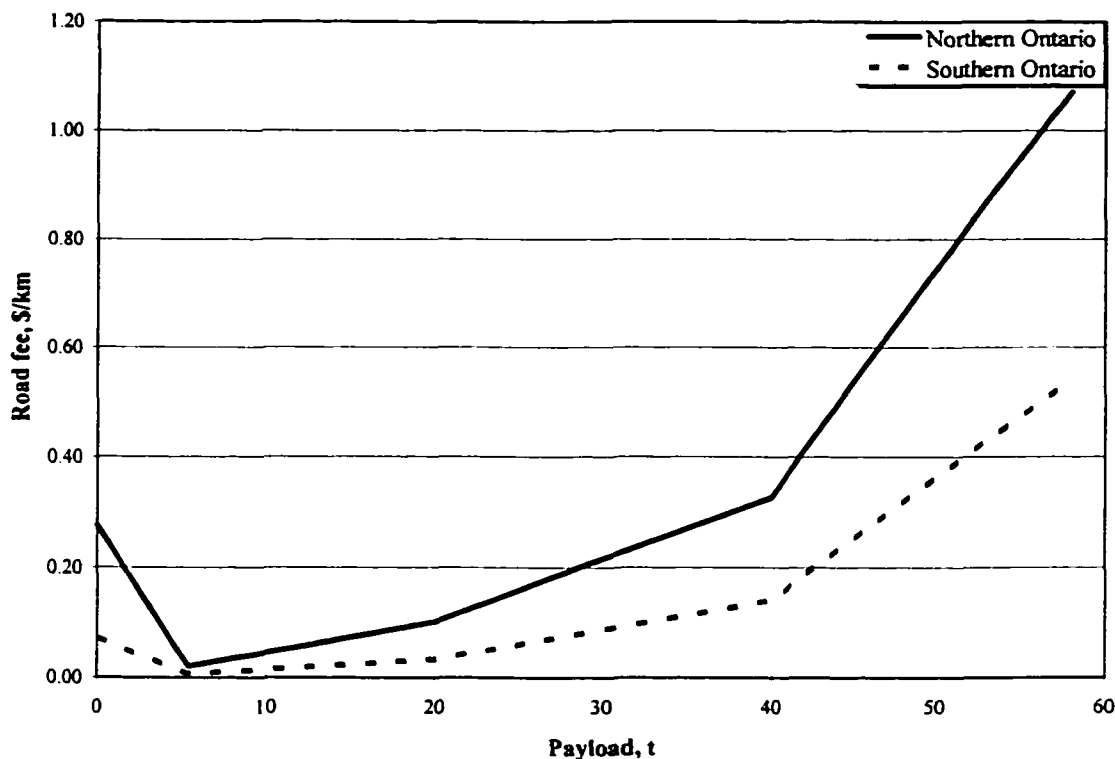

Figure 8.1. Road Usage Fees vs Payload

It can be observed from Figure 8.1 that prices in Northern Ontario should be about twice those in Southern Ontario. For example, a truck with a 40 t payload should pay about \$0.35/km in Northern Ontario, while the allocated price to similar trucks in Southern Ontario is about \$0.18/km. This difference is due to higher total and marginal costs in Northern Ontario. The difference is also due to the fact that a larger number of road users share the highway system in Southern Ontario as compared to Northern

Ontario. This results in lower cost per capital in Southern Ontario as a result of scale economies.

Figure 8.2 shows the calculated prices for different vehicle types across payload distributions. It can be observed from the figure that the prices do not vary significantly for payloads between 1 to 30 t for different vehicle types except for single unit trucks. For payloads before and beyond this range the prices are distributed within a wider band. Overall, the minimum prices are assigned to A and B-Trains and single unit trucks for heavy and light payloads, respectively. As seen from the figure, a significantly high fee is allocated to heavy semitrailers with few axles, since they damage the road system more than other vehicle types for the same payload level. The trend shown in the figure may also imply that a charging system with uniform prices for medium payloads and penalties associated with empty and heavier vehicles (especially for illegal payloads) may be appropriate to be used.

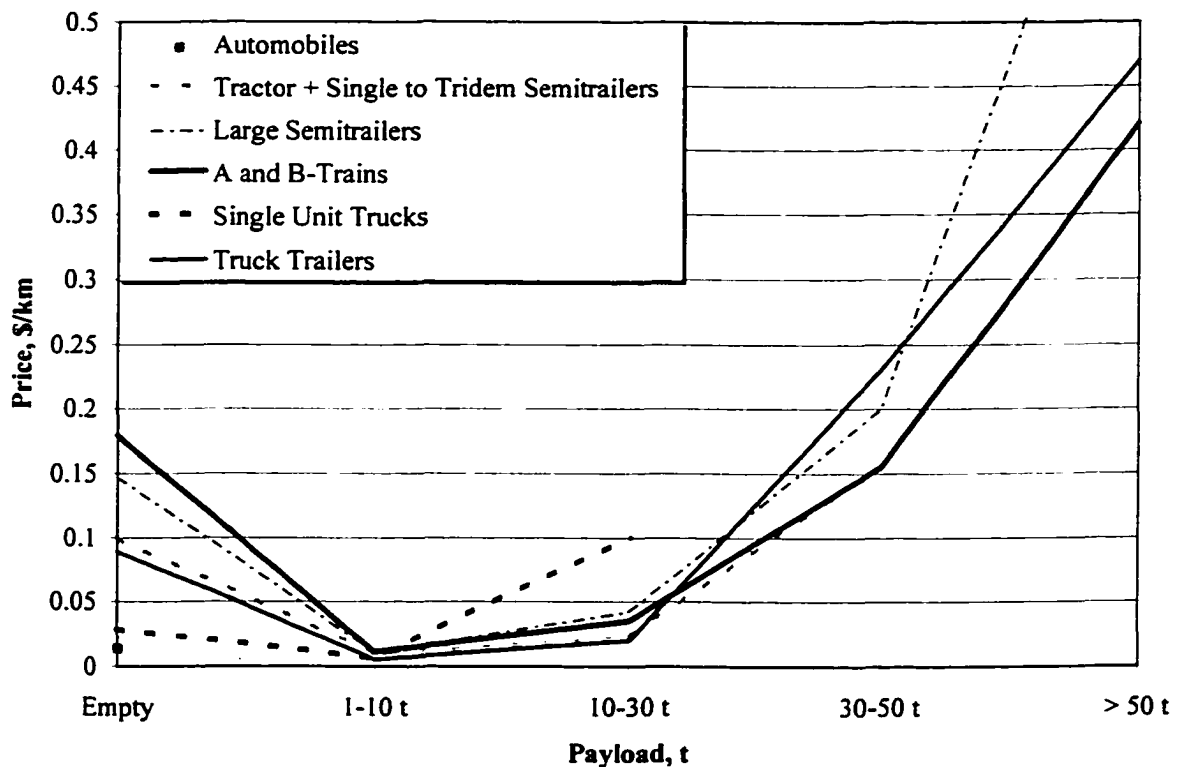

Figure 8.2. Pavement and Bridge Price vs Payload for Different Truck Types

The major goal of the cost allocation analysis in this research was to distribute the costs among different users of Ontario highway network in an equitable and efficient way. Efficiency is assumed to be achieved by encouraging more efficient vehicles to operate and trying to discourage inefficient ones. Therefore, while considering different criteria to ensure equity and admissibility of prices, the analyses sought to charge the efficient vehicles as low as possible and assign proper penalties to inefficient ones. The prices shown in Tables 8.2 to 8.10 are assumed to reflect all of the above goals and should theoretically direct road users to utilize the road system efficiently. The success of the above pricing scheme depends on many factors including the reaction of vehicle owners to the prices. This tends to be a factor of the structure of demand and supply as well as the profits each user may perceive for different vehicle choices. Even if maximum efficiency is achieved through pricing policies, it is important to realize the administration costs of applying those policies and the amount of savings in road costs. The following sections seek to analyze the feasibility of different pricing schemes and to find the effect of those schemes on user behaviour and efficient utilization of the Ontario road network.

8.4.2. Feasibility of Ideal Charges

Several factors are involved in the interaction between the pricing system, user behaviour and system performance. It is difficult to predict the effect of different pricing systems on user behaviour in terms of vehicle selection and operation at different payloads. It is beyond the scope of this research to do such a precise analysis, but the general effect of different pricing schemes on the direction of user behaviour within a broad framework is discussed.

To reach the above goals without knowing the demand functions the problem can be viewed as a game between the road agency and the road users. The road agency establishes the charging system and sets prices. Those who demand transportation services decide whether they can comply with the prices and whether to use the system or not. The road users select the appropriate vehicles and payload amounts. This eventually

affects the rate of road deterioration and therefore the road cost. In other words, the pricing system affects the user behaviour which in turn affects the total cost of the system.

The factors involved in the interaction between price and user behaviour is associated with the characteristics of both the loads and vehicles in the system. If the payloads which should be transported on the system are indivisible (they cannot be broken into several parts) then the pricing system may not affect the amount of load carried by each vehicle. Similarly, if each commodity could only be transported by a specific vehicle type then the road users would not have any control over the selection of vehicles.

In general, there are two fundamental questions that should be answered before deciding on the characteristics of a practical charging system: *i*) to what extent the users will react to a set of prices if such a system is implemented, and *ii*) what are the costs and benefits of such a system. The aim of the rest of this chapter is to find the general effect of the proposed pricing scheme on user behaviour and system performance.

8.4.3. Backward Induction

The overall interaction between participants of the road system is illustrated in Figure 8.3. The boxes represent the participants and decision makers (i.e., road agency and road users), and the lines represent the decisions and reactions by the road agencies and road users. To find the answers to the above concerns, it makes sense to work from the end of the game back toward the beginning. Two possibilities involved are that a complex pricing system is or is not implemented. In the case of implementation, the two possibilities are that the system works and directs road users to use the system efficiently or the system does not have any influence on the decision of road users. In the case of not implementing the theoretical charging system, there might be a simple system with basic user fees or an intermediate one with a combination of a basic annual fee and other variable fees. Each of these systems may or may not influence user behaviour.

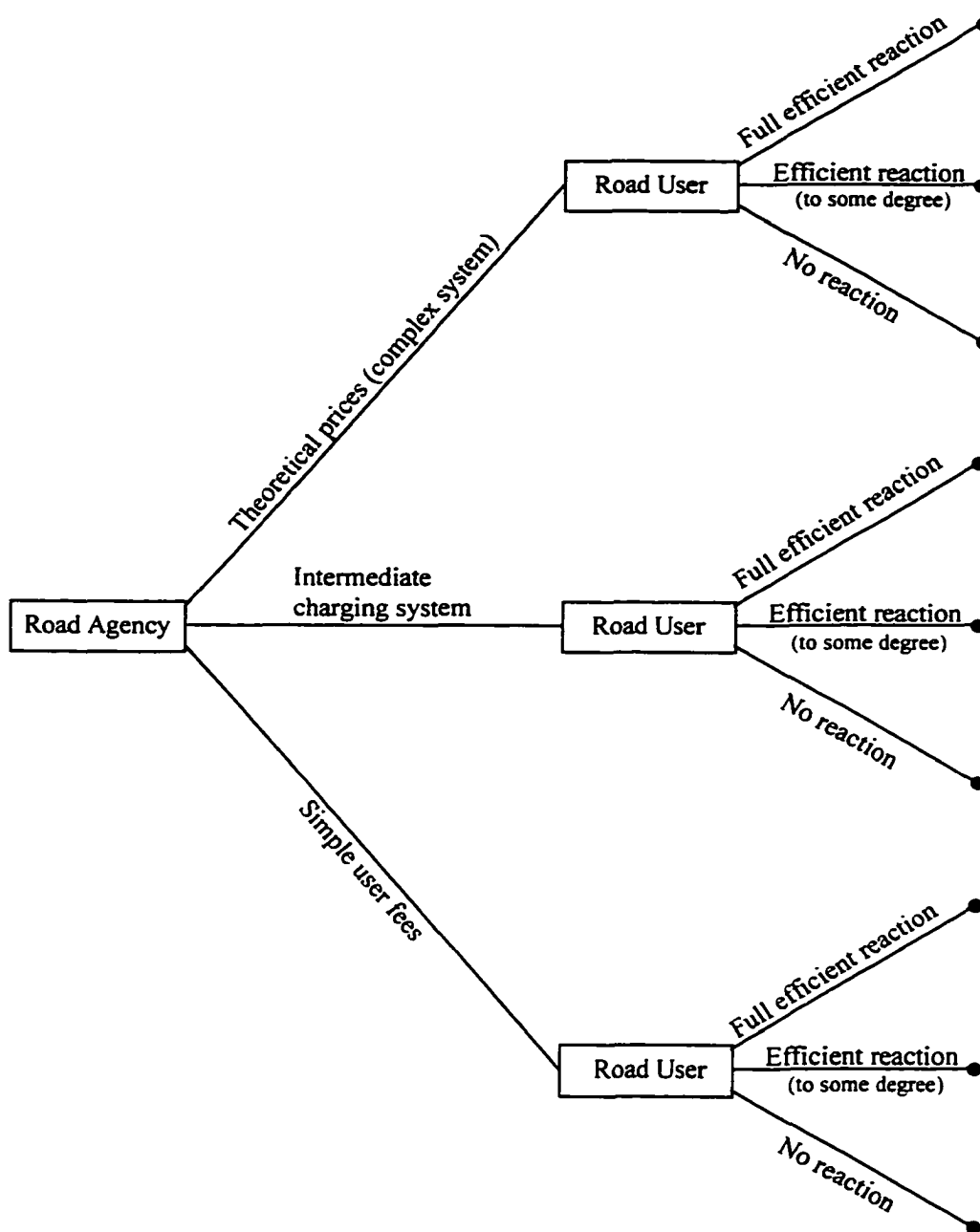

Figure 8.3. Interaction of the Pricing System and User Behaviour

Assuming that a perfect pricing system has been implemented and has had a significant influence on user behaviour, road users would use the system efficiently. This situation would imply less damage to the system and would result in lower overall life-

cycle costs. This being the case, the question now would be how much the corrected behaviour of the users in the new system would affect the total road costs.

To answer the above question, some assumptions have been made. First, it is assumed that the payloads are fully divisible (they can be transported in different proportions). If there is a demand to transport a specific commodity across the system, vehicle owners can decide to fulfill the demand using a specific vehicle and doing so in one trip. They can also divide commodity into two or more portions and carry via two or more trips. Another assumption is that each particular load can be transported by any vehicle type.

A computer program has been developed which simulates the whole system of roads and users in Ontario and calculates the life-cycle costs of the new system for different charging policy effects. The computer program estimates the generated traffic and ESALs under each scenario and re-designs the whole system of pavements. Assuming that a pricing strategy based on game theory has some effect on road users in terms of selection of vehicle and load, the computer program estimates the distribution of vehicles and payload in the system and calculates the generated ESALs and traffic for the new system. Based on this information the life-cycle cost of the system can be calculated and savings in infrastructure costs can be calculated for different scenarios.

It is assumed that the road prices may influence road user decision in terms of either the selection of vehicle type or payload amount or both. In case the road users shift to the most efficient situation by using the most efficient vehicles and carry optimum payload levels, the analysis showed an overall savings of about 6 percent in the life-cycle cost of pavements. Further analyses showed that the savings in infrastructure costs when the road users do not change the vehicles but operate at the optimal payload levels would be about 5 percent. The savings for the situation where the optimal vehicles are selected but the pricing does not influence the users to operate at the optimal payload levels would account for about 4 percent. Table 8.11 summarizes the savings in total pavement costs for each scenario. Mode shift means that the vehicle types are optimal but the distribution of payload levels is as in the existing system. Load shift means that the

selection of vehicles has not changed but the existing vehicles operate at the optimal payload levels. The last row of the table shows the savings for the most efficient situation in terms of selection of both vehicle type and payload level.

Table 8.11. The Maximum Effect of Optimal Pricing

User Reaction to Prices	Maximum Savings
Mode Shift	4%
Load Shift	5%
Both Load and Mode shift	6%

At this stage the road agency might look at the savings and decide not to implement the complex charging system; the savings might not be as significant as the road agency expected. However, assuming that the savings are justified and there is the possibility of implementing the proposed charging system, the next question would be whether road users would, in practice, react to the system as was expected. It must be understood whether the users would save money by transporting the loads at the optimal size and using optimal vehicles. If the users do not gain anything from operating at the optimal level then there would be no incentive for them to shift to more efficient vehicles.

It may be assumed that the reaction of the users would be based on profits and losses they perceive. For example, if penalties linked with the non-optimal loads decreased profits then the road users would shift their loads to different vehicles or carry them in several portions.

Some assumptions have been made in order to measure the extent of reaction of different road users to different road prices. In this regard, the road users are assumed to make their choices according to internally consistent and rational criteria. It may be assumed that all road users make optimal decisions which imply minimum overall user costs for each trip they make. Based on this assumption, truckers would shift a commodity to another type of vehicle and would break the commodity into different

portions if the per unit user cost of each load carried by a specific vehicle exceeded that carried by another vehicle.

The profits made by different trucks depend on several types of costs associated with each trip. There are other costs such as driver's wage, fuel, tire, vehicle and many other costs associated with vehicle operation. If vehicle operating costs are far higher than the road fees then the road fees may not affect the decision of road users in terms of mode or payload weight choices. On the other hand, if the operation and user costs of all vehicles were the same and the users were all rational and had perfect knowledge of the system, there would be only one vehicle type in the system operating at a particular payload. This seems to be unrealistic.

To understand the effects of a complex pricing scheme for road users, the cost implications of the pricing scheme should be analyzed from the users' point of view. Based on the assumption of road user rationality, it can be concluded that road users would react to the prices and would shift modes only if they perceive savings in their overall costs. For example, if the average cost per unit load of carrying 40 t is more than that of 20 t carried through two shipments then the truckers would prefer the second choice.

The average cost per unit load is a function of different cost elements such as vehicle operating costs and road fees. To analyze the effectiveness of different pricing schemes, it is important to know the practical costs of road users for different situations. The analyses in this research are limited to pavement and bridge costs, but other costs such as those of administration should be recovered from the road users as well.

To achieve the above information a thorough analysis is recommended. An attempt has been made to find the general picture of the effectiveness of a complex pricing scheme via an estimation of costs. In this regard it has been assumed that pavement and bridge costs constitute about 70 percent of total road expenditures (Haritos, 1973). Also, according to Transport Canada (1995) the average vehicle operating costs are about 85 cents per kilometre. These costs have been added to the previously

estimated pavement and bridge fees associated with different road users in order to estimate total road user costs.

Data points representing the user cost per unit of load per kilometre of operation have been generated and are shown in Figures 8.4 to 8.10. The user costs are the sum of road fees plus vehicle operating costs. User costs shown in the Figures represent total user costs across different road classes and are shown for different vehicle types. These costs are calculated for different pricing schemes for total cost recovery. The road fees for game-theoretic cost allocation analysis, the average pricing and the marginal cost pricing for each km of operation are calculated and summed with the vehicle operating costs. The average prices are simply obtained by calculating the average cost responsibility of different users for each kilometer of road use. The prices based on marginal costs have been obtained by allocating the marginal costs of road use and increasing them with a same percentage for different user classes in order to recover the total cost of the system.

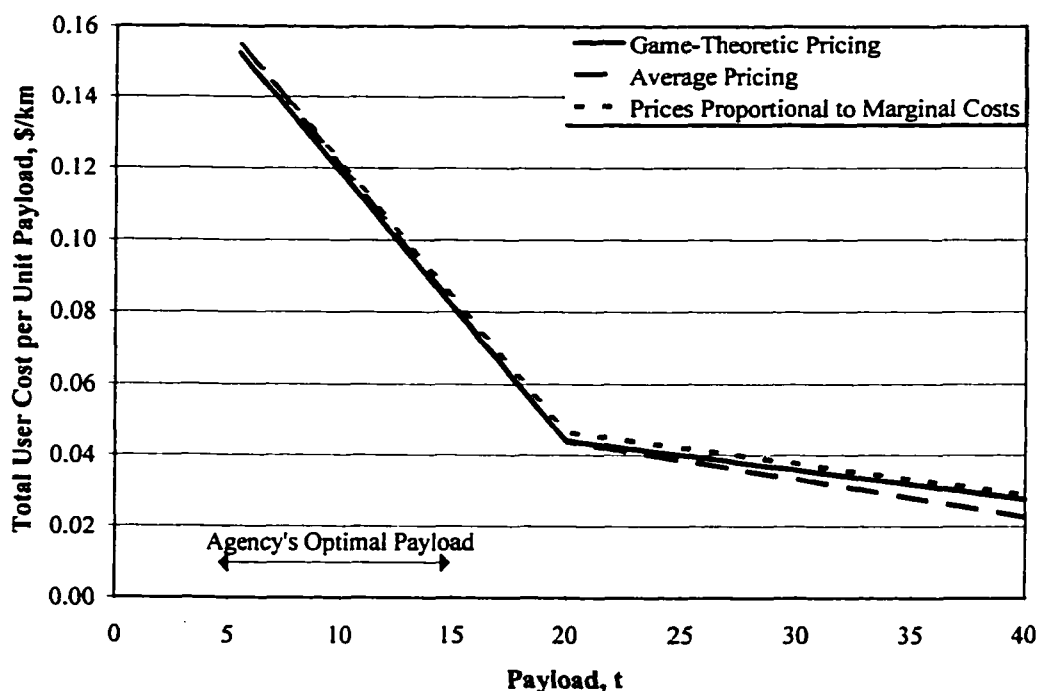

Figure 8.4. Average Per Unit Load User Cost vs Payload, Vehicle Class 2

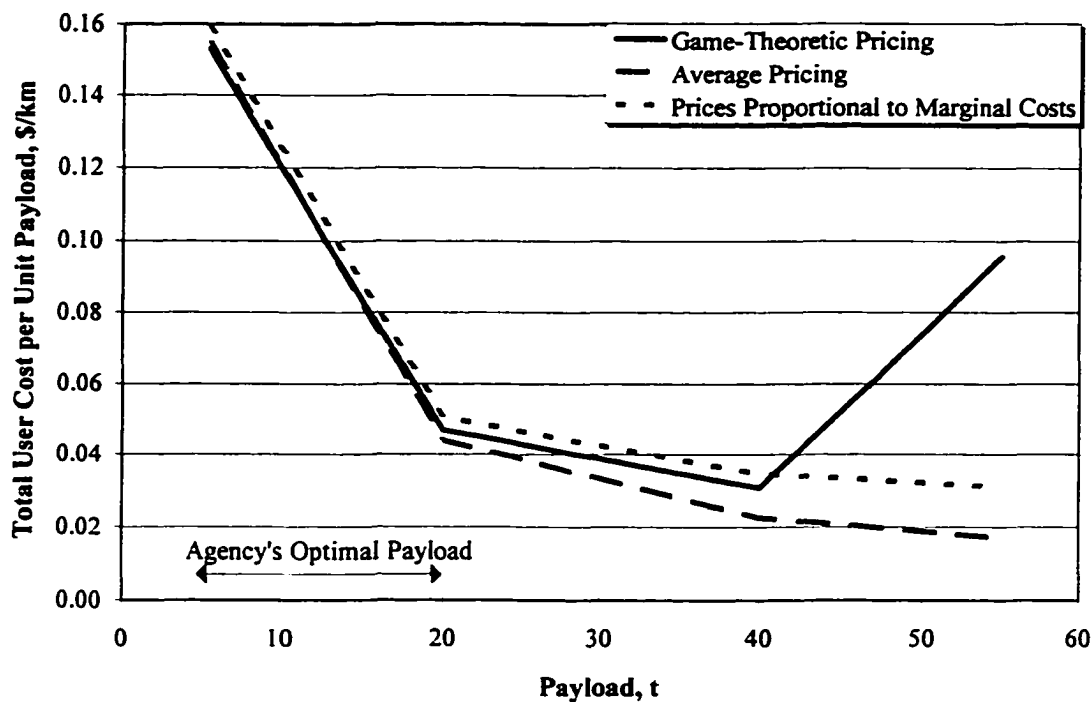

Figure 8.5. Average Per Unit Load User Cost vs Payload, Vehicle Class 3

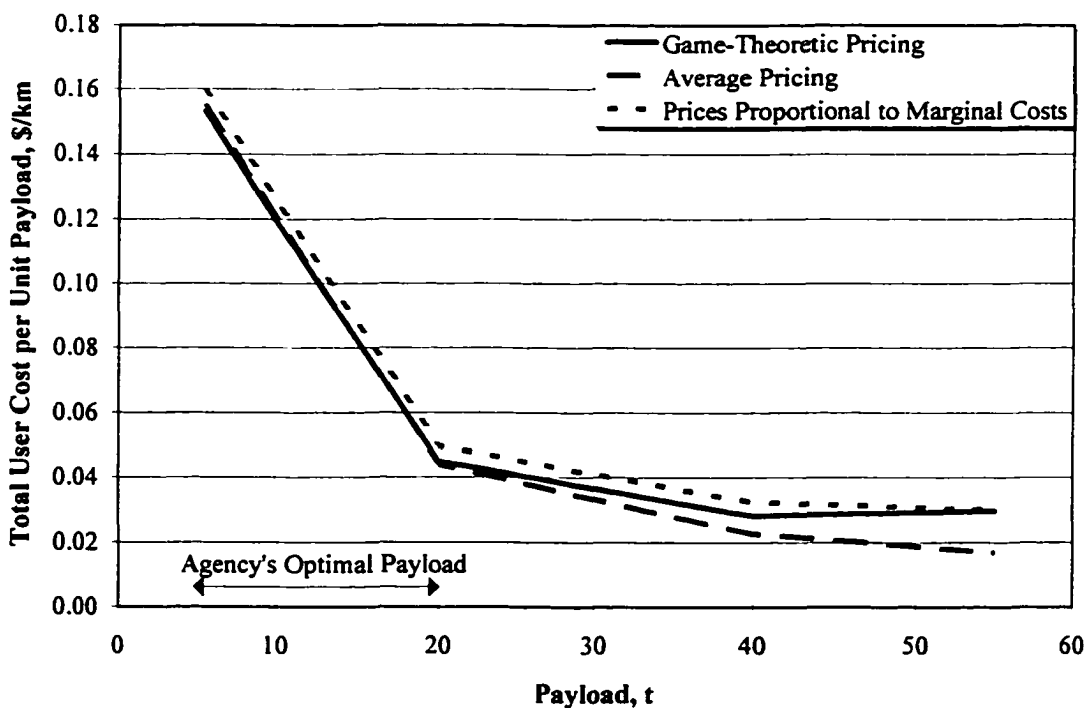

Figure 8.6. Average Per Unit Load User Cost vs Payload, Vehicle Class 4

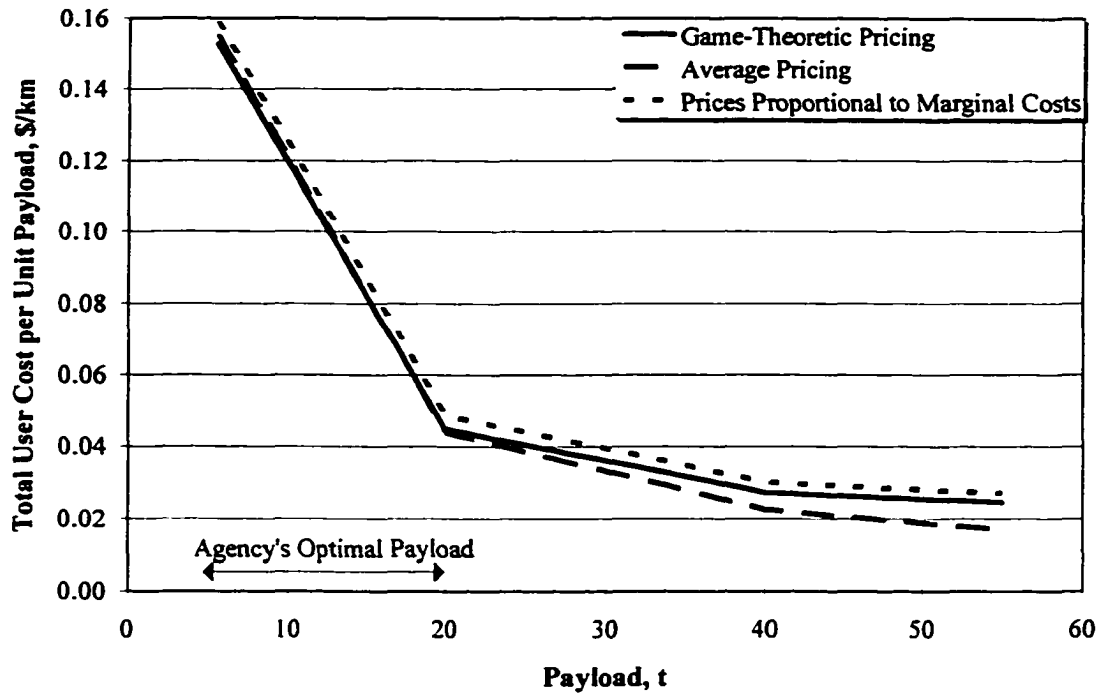

Figure 8.7. Average Per Unit Load User Cost vs Payload, Vehicle Class 5

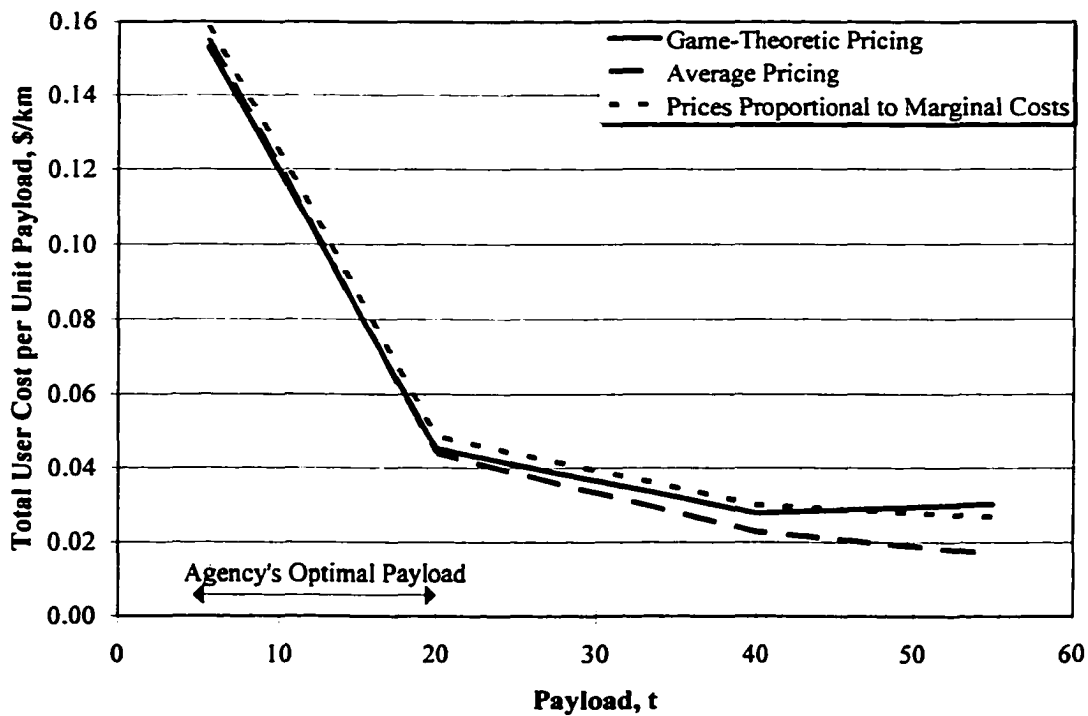

Figure 8.8. Average Per Unit Load User Cost vs Payload, Vehicle Class 6

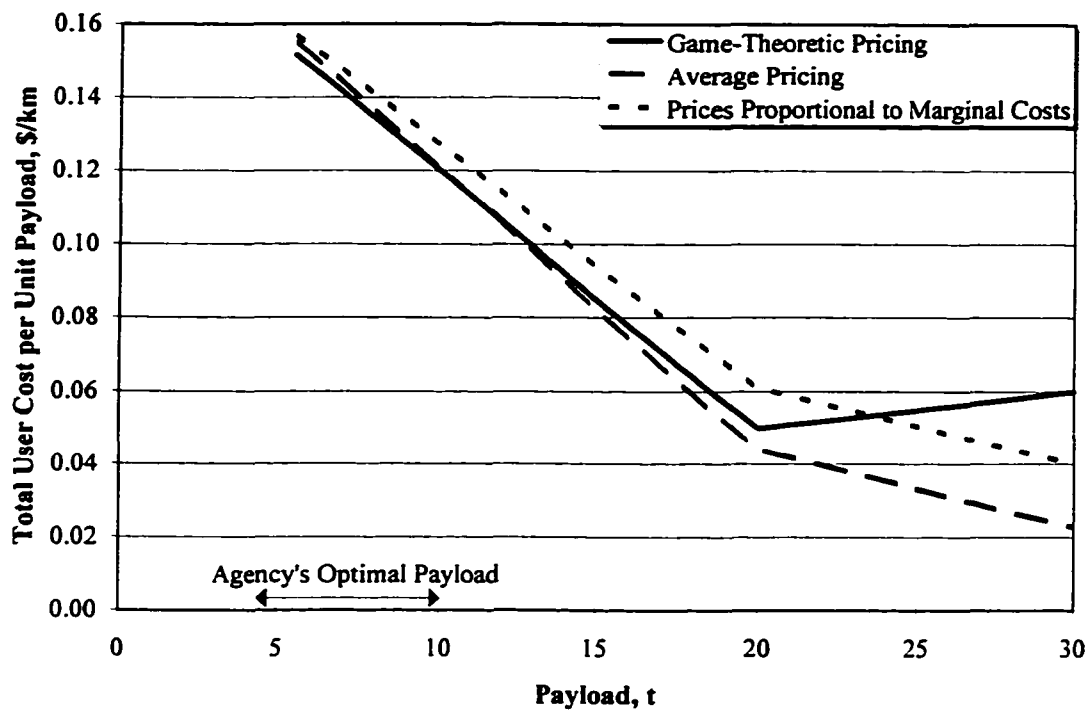

Figure 8.9. Average Per Unit Load User Cost vs Payload, Vehicle Class 7

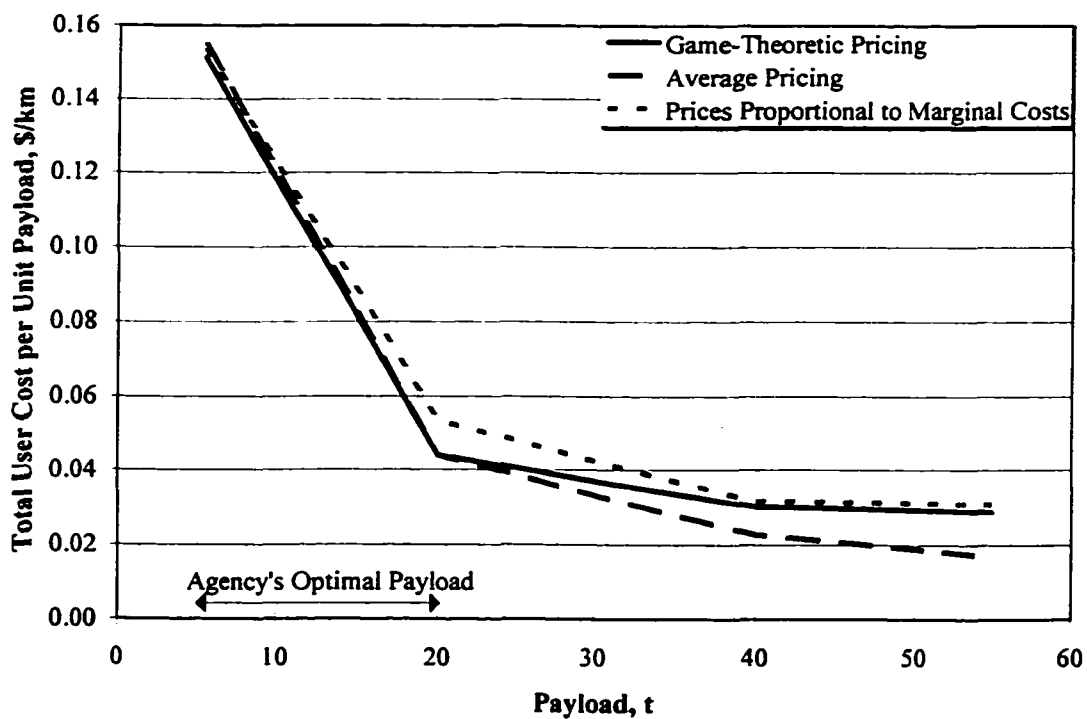

Figure 8.10. Average Per Unit Load User Cost vs Payload, Vehicle Class 8

The results in Figures 8.4 to 8.10 imply that vehicle operating costs are dominant and in most cases this leads to decreasing cost per unit of production (payload) as payload increases. Different pricing schemes do not significantly affect the per unit vehicle costs. It can be concluded that the dominance of vehicle operating costs on total user costs may lead to the fact that different pricing schemes may not be significantly different in terms of their effect on user behaviour. It can also be expected that users would only operate at road agency optimal payload ranges if they perceive lower costs. The agency optimal payloads were estimated in Chapter 5. The figures show that for most vehicle types the user costs per unit of payload would decrease as the users carry higher payloads. The only exceptions are heavy semitrailers and single trucks if they are priced according to the game-theoretic cost allocation approach. Such a pricing would likely cause the owners of single unit trucks and heavy semitrailers with few number of axles to avoid operating at payloads more than 20 t and 40 t, respectively. This is because their total costs would be higher than when they divide their payload into smaller portions. The Ontario legal load limits for these two vehicle types are 25 t and 45 t, respectively.

Table 8.12 represents the optimal payloads for different trucks from both user and agency points of view. As can be seen from the table, the optimal payload from the user point of view is higher than that from the agency point of view. This means that pricing may not significantly influence users to operate at the optimal loads perceived by road administrators.

Table 8.12. Optimal Payloads for Different Vehicles

Vehicle Class	Optimal Payload from User Point of View (t)	Optimal Payload from Agency Point of View (t)
2	-	5-20
3	40	5-10
4	40	10-20
5	-	10-20
6	40	10-20
7	20	5-10
8	-	10-20

It may be concluded that users would tend to carry higher loads up to the point they perceive higher benefits as a result of scale economies. This would be offset by higher road prices at higher vehicle loads. Even if vehicles did not operate all the time at the minimum cost per unit of load, the proposed pricing structure may not change the users' choices at payloads less than the users' optimal ones.

This would mean that it would be appropriate to introduce penalties for high loads. Penalties would not affect the behaviour of road users if a complex pricing scheme exists at low and medium loads. If part of the road cost is gathered through other taxation methods (e.g., license fees, tire taxes, and registration fees) then the users' optimal payload levels, as shown in Figures 8.2 to 8.8, would shift to the right. This would not be desirable for road administrators because the optimal payload levels from their view are lower and an increase in the users' optimal payload levels would make the system more inefficient.

The results of the above analysis suggest that the major role of a pricing system is to recover the road costs in such a way that prices do not encourage the use of inefficient vehicles and no road user subsidizes other road users. It cannot be expected that the road pricing will direct road users to operate at their most efficient level if full cost recovery is sought. Pricing above existing costs may be more influential on user behaviour but there should be further investigation to find those effects.

8.5. OPTIMAL PRICING SYSTEM

This section discusses some of the methods which could improve the efficiency of the charging system for the Ontario highway network. It must be mentioned that the work in this section is suggestive and further material and research is required in order to arrive at practical results.

A simple charging system using one time fee may result in inefficient use of the system as the road users do not perceive the amount of damage they impose with each trip they take. They would simply seek to maximize their profit by carrying larger loads in

order to minimize the operational costs per unit of payload. Because damage to the pavement is a function of axle load to the fourth power, larger axle loads would incur greater damage to the system. The above explanation would then justify the importance of a multi-part tax scheme through which trucks are responsible for the damage they impose when they take on larger payloads. The idea, therefore, is to direct truckers to operate at an optimal level. This idea will not work, even at a pricing policy with maximum control over prices, if the benefits received by trucks operating at higher loads exceed penalties they have to pay. In such a situation a complex pricing system would not have any influence on agency savings compared to a simple system. This being the case, a simple scheme would be more appropriate than a complex one because it would cost road administrators less.

Based on the assumption of user rationality and divisibility of loads, it may be assumed that a complex pricing system would affect road users only on payloads at which the user cost per unit of payload is minimum. Any pricing beyond that point would not induce road users to shift modes or take optimal loads, because it would not be to their benefit. Therefore, complex pricing policies may not be effective for low and medium load sizes. If there are other road taxes such as registration fees, the effect of pricing policies on each trip becomes less significant. Fixed fees are effective in encouraging road users to choose efficient vehicles by selecting them at the time of purchase.

Setting the actual road prices requires further analysis and information about the cost of different charging tools and their effectiveness and this is beyond the scope of this research. However, based on the analysis done in this research it may be concluded that a multi-part taxation system should be implemented based on the following criteria:

1. Some minimal fixed fees for different vehicle classes reflecting the efficiency of vehicles.
2. Occasional fees through fuel tax or any instrument that reflects the amount of usage by different vehicles for low and medium payloads.
3. Penalty fees for heavy vehicles.

These fees can be calculated from the estimated cost responsibility of different users obtained throughout this research. The estimated cost responsibility of the users can be aggregated for different vehicle groups or load categories.

As shown in this chapter, the pricing strategies most likely would not induce road users to operate at their most efficient load arrangement. Hence, the major objective of road pricing may likely be to charge the road users equitably and in such a way that prices are close to the theoretical road user fees obtained in this research. This may be accomplished by comparing the sum of the deviations of actual prices from the theoretical ones.

For example, attempts have been made here to compare two pricing systems based on average pricing method; The first set of prices are set based on the average costs of road use per ESAL and the second set of prices are established based on the average costs of road use per each kilometre of vehicle operation. The sum of the square differences for these two scenarios and game-theoretic prices are found to be equal to 59.94 and 72.85 respectively. This means that pricing according to ESALs yields results closer to theoretical prices than pricing according to kilometre of operation. This example only explains a discipline to choose between different pricing schemes.

In conclusion, road pricing for full cost recovery may not be considered as a viable strategy in directing the road users to utilize the system efficiently. Vehicle operating costs are larger than the cost impact of different users on pavements and bridges. Greater efficiency may be achieved if fees collected from road users are set based on higher than full costs of the road system (this is usually not the case with public services). If road fees are designed to generate money more than what is needed for the full cost of the roads, the question will be how that extra money should be spent. This is clearly beyond the scope of this research. If full cost recovery is an objective (as was in this research), cost allocation analysis should be carried out in order to obtain a set of equitable road prices that reflects the cost implications of different vehicles. It is important to verify the prices associated with different road users and rationally relate them to vehicle efficiencies. It is recommended that if the objective is cost recovery

(whether full cost recovery or recovery at higher or lower than total costs), and if the road pricing instruments are used, the relationship between prices and efficiency of different vehicles and equability of the prices should be checked. These prices were found in this research through the game-theoretic approach and the prices were set in such a way that they satisfied different types of rational criteria.

CHAPTER 9

Concluding Remarks

9.1. INTRODUCTION

The findings of this research can be divided into four major groups: *i*) the economic characteristics of the pavement system in Ontario, *ii*) the economic characteristics of the bridge system in Ontario, *iii*) the rational road charges that should be levied on different vehicle types, and *iv*) the implications of the road cost allocation analysis for vehicle taxation. The purpose of this chapter is to highlight some of the main findings of the research, discuss some implications regarding road design policies, taxation systems and road user charges. Recommendations for future research are developed on some aspects of the subject area.

The objectives of this research were to understand the cost characteristics of the Ontario inter-city highway network, to improve the procedures for cost allocation analysis, and to examine the effects of road prices and different pricing schemes on road users. The above goals were achieved through the use of the OPAC 2000 pavement

performance models as well as some bridge cost estimation models and an innovative game-theoretic cost allocation framework developed in this research.

9.2. CONCLUSIONS

The analyses in this research showed that due to the harsher climate in Northern Ontario pavement sections have higher life-cycle costs than those with similar subgrade and traffic conditions in Southern Ontario. For low volume roads, the pavement life-cycle costs in the north are roughly 15 percent higher than those in the south. This difference is lower (about 6 percent) for higher volume roads. The life-cycle costs of optimally designed pavements with weak subgrades may be more than 60 percent higher than those with strong subgrades for the same location and traffic conditions.

Analyses were carried out to investigate the optimal initial thickness of pavement for different subgrade and traffic conditions. For an average road with a subgrade with modulus of elasticity of 24 MPa and high traffic volume, the optimal GBE was found to be about 1200 mm. In this case, a 20 percent decrease in pavement thickness would increase the total life-cycle costs by 35 percent, while increasing the pavement thickness by 20 percent would incur an increase in total life-cycle costs of less than 5 percent.

Analyses of pavement performance in Ontario showed that the average initial life of an optimally designed pavement in Northern Ontario is about 15 years and is about 17 years in Southern Ontario. For high volume roads and strong subgrades the optimal initial pavement life is between 17 to 20 years. Such a situation usually occurs on high volume commuter highways within urban jurisdictions. This justifies the construction of high quality pavements that provide longer initial life for roads with high traffic volume.

The load carrying capacity of pavements increases exponentially with increase in pavement thickness. This causes the effect of traffic to become less important source of pavement deterioration than environmental factors. This research showed that up to 70 percent of the deterioration of optimally designed pavements was due to environment-induced damage for Ontario conditions.

A system-wide cost analysis was carried out for more than 2800 pavement segments in Ontario. It was found that on average the life-cycle costs of the pavements in Northern Ontario are roughly 10 percent higher than those in Southern Ontario. For low volume roads this difference may be as high as 16 percent. Pavement life-cycle costs versus accumulated ESALs could be represented by a logarithmic function which captures the well-known effect that pavement life-cycle costs increase at a decreasing rate. For example, it was shown that a pavement section withstanding 2,000,000 ESALs/year would require about 80 percent higher expenditures compared to a pavement section with 10,000 ESALs/year (200 times more ESALs) and with similar environmental and subgrade conditions. This reflects a much lower average cost per ESAL for higher volume roads. The pavement marginal costs per ESAL are roughly 7 percent higher for pavements in Northern Ontario than in Southern Ontario. There is a larger difference for weaker subgrades. For example, marginal costs imposed by an extra ESAL on pavement sections with $M_s = 42$ MPa and 40 million accumulated ESALs in Northern and Southern Ontario are \$ 0.01 /km and \$ 0.009 /km respectively.

The bridge cost analysis showed that the deterioration of bridges is largely due to environmental factors and deicing chemicals and maintenance costs are less than 0.2% of the initial construction costs. It was concluded that the major element of bridge life-cycle cost is the initial capital cost of construction. Based on available bridge cost data, construction cost was found to exhibit a linear relationship with deck area. It was found that on average, in most regions of Ontario, bridge construction costs can be estimated at about \$1000 /m² (present worth) of deck area.

The bridge cost allocation analysis in this research indicated that bridge user fees should increase significantly as the GVW associated with each truck increases. It was found that the total bridge costs is about 14 percent of total road construction and maintenance costs in Ontario. It was also concluded that trucks operating in Northern Ontario should pay roughly three times more than those in Southern Ontario for bridge costs. For example, trucks which carry about 50 t should on average pay about \$0.06 /km

and \$0.02/km in Northern and Southern Ontario respectively, while the estimated fees for trucks carrying 20 t payload are estimated to be about \$0.03/km and \$0.01/km.

The relationship between vehicle design loadings and bridge costs were established and used to evaluate the cost of the Ontario bridge system for different design loadings. The analyses showed that the minimum cost of bridge construction would be about 50 percent of the existing cost if the only users of the bridge system were automobiles. Heavy semitrailers with a low number of axles have the largest impact followed by 2 and 3 axle B-Trains, heavy haul A and B-Trains, 5+ axle semitrailers, truck trailers, single and tandem and tridem semitrailers, and finally single unit trucks. The present worth of the construction cost was estimated to be about \$10.8 billion for the bridges in the bridge inventory database. The analysis of bridge costs indicated that those bridges would have cost about \$5.5 billion if they were exclusively designed to withstand automobile loads.

Several computer programs were developed to analyze the performance and cost of pavement and bridge sections in Ontario under different conditions and policy scenarios at both the project and network levels. The programs are useful decision support tools to analyze the effects of different design and vehicle configuration policies on road costs. Using the computer programs, the costs of accommodating passenger cars alone (excluding commercial vehicles) were found to be about 45 to 80 percent of the total cost of existing roads. This ratio was found to be larger in Northern Ontario than in Southern Ontario.

In general, it was found that single unit trucks are the most efficient vehicles for light loads and vehicles with a large number of axles (e.g., A and B-Trains) are more economical for transporting heavy loads. In general, it was found that pavement costs would decrease if vehicles avoid transporting at their maximum capacity. The pavement cost minimizing payload levels are found to be between 5 t to 20 t depending on the type of vehicle. This value is much lower than optimal payload from the road user point of view. It was also shown that the cost imposed by automobiles and light vehicles was very low compared to the cost imposed by commercial trucks. Heavy trucks were found to be up to 200,000 times more damaging than automobiles. However, this did not justify the

allocation of road costs between different vehicles based on the proportion of their cost impacts on the highways. This is because there are some fixed costs associated with road infrastructure and the fact that automobile loads do not impose significant damage because pavements and bridges are designed to withstand heavy axle loads. The overall life-cycle cost of the pavement samples in this study were estimated to be about \$2.18 billion. This figure would be reduced to \$1.38 billion if the pavements were designed for automobiles (about 60 percent of the total costs of the existing system).

In the case of a system designed primarily for commercial vehicles, the costs were estimated by first including and then excluding the effect of traffic on road capacity. It was found that the overall pavement life-cycle costs would not decrease if the number of lanes were reduced as a result of traffic considerations. It was shown that if trucks were the only users of the road system, the present value of life-cycle costs would be \$2.18 billion for the existing system. If the number of lanes were reduced as a result of a reduction in traffic, the actual life-cycle costs would even increase to \$2.29 billion.

A major contribution of this research was to develop a new cost allocation procedure based on the concepts of cooperative game theory. The proposed method was defined by an optimization framework consisting of an objective function and several constraints which reflect the rational relationships between the characteristics of vehicles and their associated cost responsibilities. The constraints of the framework in this research were arranged to reflect full cost recovery and to ensure that no vehicle or group of vehicles is charged less than its marginal cost or more than its stand-alone cost. The objective function used in this study was set to maximize the production efficiency in the system by arrangement of lower fees to more efficient vehicles and vice versa for inefficient ones. The framework has several advantages to existing methods. The most important advantages of the framework are flexibility for adjustment, integrity, and transparency in observing the details of the costs and prices associated with different vehicles. Once the method is established, it could be adjusted to reflect different technical, economical and political conditions with minimum effort.

A wide range of costs were allocated to different vehicles of the Ontario highway system. However, the results of the cost allocation analysis generally suggest that significantly higher fees should be assigned to overloaded trucks due to the exponentially increasing damage effect of increasing axle loads. Also relatively high fees are assigned to empty or very light trucks to discourage the inefficiency created by the operation of empty vehicles. The results of the cost allocation in this research suggests that road users in Northern Ontario should be charged almost twice as much as those in Southern Ontario. This is due to higher average and marginal costs in Northern Ontario and larger number of users in Southern Ontario. For example, a truck with a 40t payload should pay about \$0.35/km in Northern Ontario, while the allocated price to similar trucks in Southern Ontario is about \$0.18 /km. Overall, the minimum prices are assigned to A and B-Trains and single unit trucks for heavy and light payloads, respectively. A significantly higher fee is allocated to heavy semitrailers with few axles, since their damage implication per unit of payload is more than other vehicle types hauling heavy payloads. On average across Ontario, the highest road fee for low and medium payload levels (1 t to 30 t) has been assigned to 3 and 4 axle semitrailers at \$0.05 /km followed by heavy haul A and B-trains at \$0.04 /km, 5+ axle semitrailers at \$0.03 /km, 2 and 3 axle B-Trains at \$0.03 /km, single unit trucks at \$0.02 /km (for 1 t to 10 t payload range), single to tridem semitrailers at \$0.02 /km, and truck trailers at \$0.01 /km. For heavier payloads of more than 30 t the highest road fee has been assigned to 3 and 4 axle semitrailers at \$0.37 /km followed by truck trailers at \$0.24 /km, 2 and 3 axle B-Trains at \$0.20 /km, 5+ axle semitrailers at \$0.19 /km, and heavy haul A and B-trains at \$0.16 /km.

Vehicle operating costs dominate the total user costs and thus, the effect of pricing on efficient selection of vehicle type and payload weight would be limited. The average vehicle operating cost is about \$0.85 /km while the average road fee for trucks calculated in this research is about 0.06 /km. It was concluded that even a complex pricing system based on the results of the game-theoretic cost allocation framework (for 100% cost recovery as an objective) may not force road users to select the most efficient vehicle and payload weight. It was also shown that if a complex pricing scheme through which vehicles would be charged exactly the suggested game-theoretic prices were

implemented, and if users reacted to such a pricing scheme in the most efficient way (although the analysis in this research imply that this is not very likely) then the total savings in pavement life-cycle costs would be about 6 percent. The pricing tools may not be effective in directing the utilization of the road facilities to the most desirable level unless the collected fees are set above the total system costs or if loading laws are strictly enforced. However, pricing strategies may affect the selection of vehicles and may result in more efficient utilization of vehicle types.

9.3. RECOMMENDATIONS

There are a few directions in which the contribution of this work can be extended. Improving the road charging system in such a way that the pricing arrangements regulate the utilization of the system in an efficient way is of definite interest. This can be achieved by improving the efficiency measures in the game-theoretic cost allocation procedure. In this research vehicle efficiencies were identified based on their output in terms of payload weight and damage to the road infrastructure. The efficiency in the cost allocation procedure may be improved by considering the economic value of different commodity types rather than their weight alone.

Another problem would be to compare the benefits received by the movement of trucks with automobiles. There was no means to compare the outputs of automobiles with those of trucks in this research. The results of the cost allocation analysis will be improved if the monetary value of automobile and truck movements can be modelled and verified.

The relationship between prices and user behaviour is complex. This relationship is important to understand as it affects the overall efficiency of the road transportation system on which considerable funds are expended. It would be valuable to study the impact of user costs on the selection of transportation modes and the level of operation of those modes. It would be useful to find the demand and supply functions to estimate the demand for road services and the quantity of output at different road user prices.

Existing databases are not complete and some data had to be estimated. Although some of the information was estimated based on sound rationales and reliable procedures, a database containing information on actual pavement layer thicknesses, subgrade information, traffic data, geometric specifications and cost characteristics will improve the quality of the analysis. It is also recommended that the cost analysis of inter-city highways be carried out with regard to the cost implications resulting from both traffic and road damage simultaneously.

The focus of the study has been on pavement and bridge costs. Those costs constitute most of the road costs and are the major concerns of road agencies. However, to present a more global view of road costs and design implications, it is recommended that analyses be extended to both user and agency costs. A greater focus on user and non-user costs (externalities) is suggested.

Models of bridge deterioration and costs are not well developed. It would be useful if such models were made available. It would be particularly useful if separate effects of traffic and environmental factors on bridge deterioration for different vehicle design scenarios were investigated with more care.

REFERENCES

- American Association of State Highway and Transportation Officials (AASHTO). (1993). *AASHTO Guide for Design of Pavement Structures*. Washington D.C., USA.
- American Institute of Steel Construction (AISC). (1986). *Load and Resistance Factor Design Manual of Steel Construction*. Chicago.
- Ariaratnam, S. T., 1994. *The Investigation of Methods to Assist Decision Makers Regarding Bridge Maintenance, Rehabilitation, and Restoration Activities*. Ph.D. Thesis, Department of Civil Engineering, University of Illinois at Urbana-Champaign, USA.
- Australian Interstate Commission. (1990). *Road Use Charges and Vehicle Registration: A National Scheme*. Volume 1, March. Australia General Public Service, Canberra. Chicago.
- Bannantine, Julie A., J. J. Comer and J. L. Handrock. (1990). *Fundamentals of Metal Fatigue Analysis*. Prentice-Hall, Inc. New Jersey, USA.
- Bryan, N. (1972). *More Taxes and More Traffic*. Canadian Tax Papers, No. 55, Canadian Tax Foundation, Toronto, Canada.
- Bunting, P.M. (1991). *The Basis for Highway User Charges: A Discussion Report*. Transport Canada, Economic Research Branch, Canada.
- Congressional Budget office (CBO). (1992). *Paying for Highways, Airways, and Waterways: How Can Users Be Charged?* Congress of the United States. Washington, D.C., USA.
- Cooper, Sol E. (1985). *Designing Steel Structures: Methods and Cases*. Englewood Cliffs, N. J.: Prentice-Hall.
- Costa, Carlos A. B. (1990). *Readings in Multiple Criteria Decision Aid*. Springer-Verlag.
- Federal Highway Administration (FHWA). (1982). *Final Report on Federal Highway Cost Allocation Study*. U.S. Department of Transportation, Washington, D.C., USA.
- Frankena, Mark W. (1979). *Urban Transportation Economics: Theory and Canadian Policy*. Butterworths & Co., Toronto, Canada.

- Fwa, T. F. and K. C. Sinha. (1985). *Thickness Incremental Method for Allocating Pavement Construction Costs in Highway Cost-Allocation Study*. Transportation Research Record 1009, pp. 1-7.
- Garcia-Diaz, A. and A. Villareal-Cavazos. (1985). *Two Alternative Approaches to the Highway Cost Allocation Problem*. Proceedings from the First North American Conference on Managing Pavements. Toronto, Ontario, Canada, March, Vol. 1, pp. 3.47 - 3.58.
- Gillespie, T. D., S. M. Karamihas, M. W. Sayers, M. A. Nasim, W. Hansen and N. Ehsan. (1993). *Effects of Heavy-Vehicle Characteristics on Pavement Response and Performance*. National Cooperative Highway Research Program (NCHRP), Report 353. Transportation Research Board, National Research Council. Washington, D.C., USA.
- Gillen, David and T. H. Oum. (1991). *Transportation Infrastructure: Pricing, Investment and Cost Recovery*. Technical Seminar on Infrastructure Pricing, Investment Decision and Financing, Volume 1. Royal Commission on National Passenger Transportation, Canada.
- Haas, R., W. Hudson. and J. P. Zaniewski (1994). *Modern Pavement Management Systems*. Krieger Publishing Company, Malabar, Fla., USA.
- Haritos, Z. (1973). *Rational Road Pricing Policies in Canada*. Canadian Transport Commission, Ottawa, Canada.
- He, Z., Y. Cai and R. Haas. (1995). *OPAC Updating Project Stage 2: Engineering Report*. Department of Civil Engineering, University of Waterloo, Report prepared for Ministry of Transportation Ontario, Canada.
- Heaney, J. P. (1979). *Efficiency / Equity Analysis of Environmental Problems: A game Theoretic Perspective*. Applied Game Theory, pp. 352-369.
- Heggie, I. (1991). *User Charges and Accountability for Roads*. World bank, Washington, D.C., U.S.A.
- Hudson, W. Ronald, M. T. McNerney and T. Dossey. (1991). *A Comparison and Re-Analysis of the AASHO Road Test Rigid Pavement Data*. Paper presented to Transportation Research Board 70th Annual Meeting, Washington D.C., U.S.A.
- Hurley, W. (1989). *The Efficient Allocation of Runway Capacity*. Transportation Development Centre, Transport Canada, Montreal, Canada.
- Hutchinson, B. G. (1991). *Some Technical Issues in Implementing Road User Pavement Damage Charges*. Royal Commission on National Passenger Transportation, Canada.

- Hutchinson, B. G. (1990). *Large-Truck Properties and Highway Design Criteria*. Journal of Transportation Engineering 116(1).
- Hutchinson, B. G., F. Nix, R. Green and R. C. G. Haas. (1989a). *Evaluation of Allowable Gross Weights for the Aggregate Carrier Industry*. A report prepared for the Safety and Regulations Program, Ministry of Transportation, Ontario.
- Hutchinson, B. G. (1989b). *Pavement Damage Implications of Ontario Bridge Formula Axle Group Weight Limits*. Canadian Journal of Civil Engineering 16, pp. 693-697.
- Hutchinson, B. G. and R. C. G. Haas. (1991). *Trade-Offs Between Truck Transportation Costs and Infrastructure Damage Costs*. Department of Civil Engineering, University of Waterloo, Ontario, Canada.
- Jansson, J. O. (1984). *Transport System Optimization and Pricing*. John Wiley & Sons. New York, NY, USA.
- Jung, F. W., W. A. Phang. (1974). *Elastic Layer Analysis Related to Performance in Flexible Pavement Design*. Transportation Research Record No. 521, pp. 14-29, Transportation Research Board, Washington, DC, USA.
- Jung, F. W., R. Kher and W.A. Phang. (1975). *Ontario Pavement Analysis Costs: A Performance Prediction Subsystem-Flexible Pavement*. Ontario Ministry of Transportation and Communications, Toronto, Canada.
- Kher, R. and W. A. Phang. (1975). *Ontario Pavement Analysis Costs: Economic Analysis Elements*. Toronto: Ministry of Transportation and Communications, Toronto, Canada.
- Lacroix D., J. Bowland, F. Collins. (1993). *Transportation Taxation and Competitiveness*. Transportation Association of Canada (TAC), Ottawa, Canada.
- Lee, Douglas B. (1982). *Net Benefits From Efficient Highway User Charges*. Transportation Research Record No. 858, pp. 14-20, Transportation Research Board, Washington, DC, USA.
- Litman, Todd. (1995). *Transportation Cost Analysis: Techniques, Estimates and Implications*. Victoria Policy Institute, Canada.
- Littlechild, S. C. (1970). *A Game Theoretic Approach to Public Utility Pricing*. Western Economic Journal 8(2), pp. 55-82.
- Littlechild, S. C. and G. F. Thompson. (1977). *Aircraft Landing Fees: A Game Theory Approach*. Bell Journal of Economics 8: 186-204.

- Mallett, James J. L. (1990). *Trade-Offs Between Line Haul and Pavement Damage Costs of Inter-City Trucking*. M.A.Sc. Thesis, University of Waterloo, Waterloo, Canada.
- McRae, James J. (1991). *Infrastructure User Charges and the Impact on the Competitive Position of Canadian Carriers*. Royal Commission on National Passenger Transportation, Canada.
- Merritt, F. S., M. K. Loftin, J. T. Ricketts. (1961). *Standard Handbook for Civil Engineers*. Fourth Edition. McGraw-Hill, New York, NY, USA.
- Ministry of Transportation of Ontario (MTO). (1990). *Pavement Design and Rehabilitation Manual*. Toronto, Canada.
- Ministry of Transportation of Ontario (MTO). (1991). *1988 Ontario Commercial Vehicle Survey*. SDO-90-01, MTO, Toronto, Ontario, Canada.
- Ministry of Transportation of Ontario (MTO). (1991). *Bridge Code, 3rd Edition*. MTO, Toronto, Ontario, Canada.
- Ministry of Transportation of Ontario (MTO). (1996a). *Highway Information Management System*. MTO, Toronto, Ontario, Canada.
- Ministry of Transportation of Ontario (MTO). (1996b). *Vehicle Dimensions and Weight Limits in Ontario*. MTO, Toronto, Ontario, Canada.
- Ministry of Transportation of Ontario (MTO). (1997). *Impact on the Highway Infrastructure of Existing and Alternative Vehicle Configurations and Weight Limits*. Technical Report, MTO, Toronto, Ontario, Canada.
- Mirman, Leonard J., Y. Tauman and I. Zang. (1985). *On the Use of Game-Theoretic Concepts in Cost Accounting*. In P. H. Young (Ed), Cost Allocation: Methods, Principles, Applications. pp. 55-77.
- Mohring, Herbert D. and I. Harwitz. (1962). *Highway Benefits: An Analytical Framework*. Northwestern University Press, Evanston, Illinois, U.S.A.
- Moses, Fred. (1989). *Effects on Bridges of Alternative Truck Configurations and Weights*. Transportation Research Board. NCHRP Contract No. HR 2-16(b) and National Academy of Sciences Subcontract No. DOT-3020-0-001, USA.
- Nicholls, R. (1991). *Ratios of pavement Damage to User Fees*. Transportation Research Record No. 1311, pp. 277-285. Transportation Research Board, Washington, DC, USA.
- Nix, Fred P., M. Boucher and B. G. Hutchinson. (1991). *Road Costs*. Royal Commission on National Passenger Transportation, Canada.

- Nix, Fred P. and J. Jones. (1994). *Highway Finance Theory and Practice*. Transportation Association of Canada, Ottawa, Canada.
- Oregon Department of Transportation. (1993). *1992 Motor Vehicle Cost Responsibility Study; Final Report and Technical Appendum*. Oregon DOT, Transportation Development Branch, Transportation Research Section, Future Technology Research Unit, Oregon, USA.
- Oum, Tae H. and M. W. Tretheway. (1988). *Ramsey Pricing in the Presence of Externality Costs*. Journal of Transport Economics and Policy 11 (3), 307-317.
- Oum, Tae H., Waters, W. G. and Jong S. Y. (1990). *A Survey of Recent Estimates of Price Elasticity of Demand for Transport*, Working Paper, WPS 359, World Bank, Washington, D.C., USA.
- Rilett, L. R., B. G. Hutchinson and R. C. G. Haas. (1989). *Cost Allocation Implications of Flexible Pavement Deterioration Models*. Washington: Transportation Research Board, Washington D.C., USA.
- Road and Transportation Association of Canada (RTAC). (1990). *Canada's Highways: The Future*. Ottawa, Canada.
- Road and Transportation Association of Canada (RTAC). (1988a). *Canada's Highways: A profile*. Ottawa, Canada.
- Road and Truck Association of Canada (RTAC). (1988b). *Expert Systems and Heavy Trucks*. Ottawa, Canada.
- Road and Truck Association of Canada (RTAC). (1977). *Pavement Management Guide*. Pavement Management Committee, Ottawa, Canada.
- Rothengatter, W. (1991). *Infrastructure Pricing, Cost Allocation and Investment in Europe*. Institute for Economic Policy Research of the University of Karlsruhe, Germany.
- Samet, D., Y. Tauman and I. Zang. (1982). *An application of the Aumann-Shapley Prices for Cost Allocation in Transportation Problems*. Mathematics of Operation research 17, PP. 25-42.
- Schauer, David A. (1991). *Transportation Spending and Economic Growth*. American Public Transit Association, Washington D.C., USA.
- Sinha, Kumares C. (1994). *Technical Issues in Highway Cost Allocation*. Highway Cost Allocation Workshop, Federal Highway Administration, Washington, D.C., USA.
- Small, K., C. Winston and C. Evans. (1989). *Road Work: A new Highway Pricing and Investment Policy*. Brookings Institute, Washington, D.C., USA.

- Small, K. and C. Winston. (1989). *Optimal Highway Durability*. American Economic Review 78 (3), 561-569.
- Small, Kenneth A. (1990). *Highway Infrastructure: Crisis in Finance or Crisis in Management?*. Institute of Transport Studies Review 13 (2), Institute of Transportation Studies, University of California.
- Schelling, David R. (1985). *The Influence of Heavy Trucks on the Overload and Allocation of User Costs on Bridge Structures*. A report prepared for AAA Foundation for Traffic Safety, Virginia, U.S.A.
- Statistics Canada. (1993). *Road Motor Vehicles: Registration*. Catalogue No. 53-219. Annual. Ottawa, Canada.
- Tonias, D. E. (1994). *Bridge Engineering*. McGraw-Hill Inc.
- Transportation Association of Canada (TAC). (1993). *Transportation in Canada: 1993 report*. Ottawa, Canada.
- Trucking Research Institute. (1990). *Rationalization of Procedures For Highway Cost Allocation*. The Urban Institute, SYDEC, INC. KT Analytics, Inc., Jack Faucett Associates, Inc., USA.
- Tee A., K. C. Sinha and E. C. Ting. (1986). *Multi-Incremental Cost Allocation Methodology for Bridges*. Transportation Research Record No. 1072, pp. 31-39.
- Villarreal-Cavazos, A. and A. Garcia-Diaz. (1985). *Development and Application of New Highway Cost-Allocation Procedure*. Transportation Research Record No. 1009, pp. 34-40. Transportation Research Board, Washington, DC, USA.
- Wheeler, P. K. (1996). *Transportation Cost Allocation: Applying Cost Allocation in a Multimodal Environment*. Transportation Research Record No. 1558, pp. 8-15. Transportation Research Board, Washington, DC, USA.
- World Bank. (1991). *User Charges and Accountability for Roads*. Technical Seminar on Infrastructure Pricing, Investment Decision and Financing, Volume 2. Royal Commission on National Passenger Transportation, Canada.
- Xanthakos, Petros P. (1996). *Bridge Strengthening and Rehabilitation*. Prentice-Hall, Inc. New Jersey, USA.
- Young, Peyton H. (editor). (1985a). *Cost Allocation: Methods, Principles, Applications*. Elsevier Science Publishers, Amsterdam, Netherlands.
- Young Peyton H. (1985b). *Methods and Principles of Cost Allocation*. In P. H. Young (Ed), Cost Allocation: Methods, Principles, Applications, pp. 3-29.

APPENDIX A

Nominal Values of Variables in Figure 2.8

Table B-1. Nominal Value and Range of Values for Vehicle, Tire, and Pavement Variables
[Source: Gillespie et al., 1994]

Truck Factors	Range of Values	Nominal Values
Axle load	10-22 kips	18 kips
Gross vehicle weight	32-140 kips	80 kips
Axle spacing	48-96"	51"
Tandem static load sharing	LSC=1-1.25	perfect load sharing
speed	45-65 mph	55 mph, tire loads held at static values
single axle suspension type	air spring, taper leaf, flat leaf	static loads
tandem axle suspension type	air spring, 4-spring, walking beam	static loads
wheel path location	lane edge to lane center	lane center
Tire Factors		
Inflation pressure	75-120 psi	85 psi
Dual versus wide-base single	dual and wide-base single	dual tires
Rigid Pavement Factors		
Roughness	80-240 in/mi (4.25-2.5 PSI)	tire loads held at static values
Slab thickness	7-10 inches	10 inches
Base layer thickness	0-8 in. granular	8 inches, granular
Subgrade strength	50-300 pci	200 pci
Slab length	12-60 feet	CRCP
Joint load transfer	aggregate interlock vs. dowel bars	CRCP
Temperature gradient	1° F/in	0° F/in
Flexible Pavement Factors		
Roughness	80-240 in/mi (4.25 - 2.5 PSI)	static loads
Surface temperature	77-120° F	77° F
Wear course thickness	2-6.5 inches	5 inches
Base layer thickness	4-11 inches	8 inches
Subgrade strength	1-20 ksi	2.5 ksi

APPENDIX B

Frequency Distribution of Pavement Marginal costs

The histograms B.1 to B.9 illustrate the variation number of marginal cost within different roads with different pavement sections with different traffic levels in Northern and Southern Ontario. For example, Figure B.1 show that there are 37 pavement sections that imply the marginal cost of \$0.05 to \$0.08 per ESAL for low volume roads with less than 20,000 initial year ESALs in Northern Ontario.

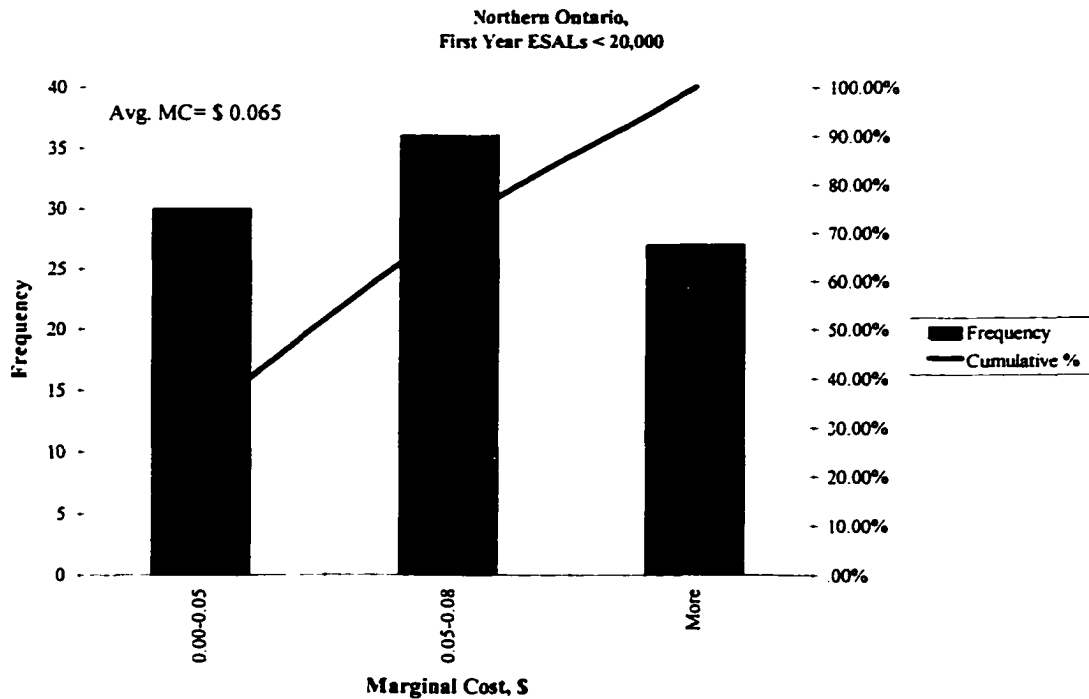

Figure B.1. Frequency Distribution of Marginal Cost for Road Class 1

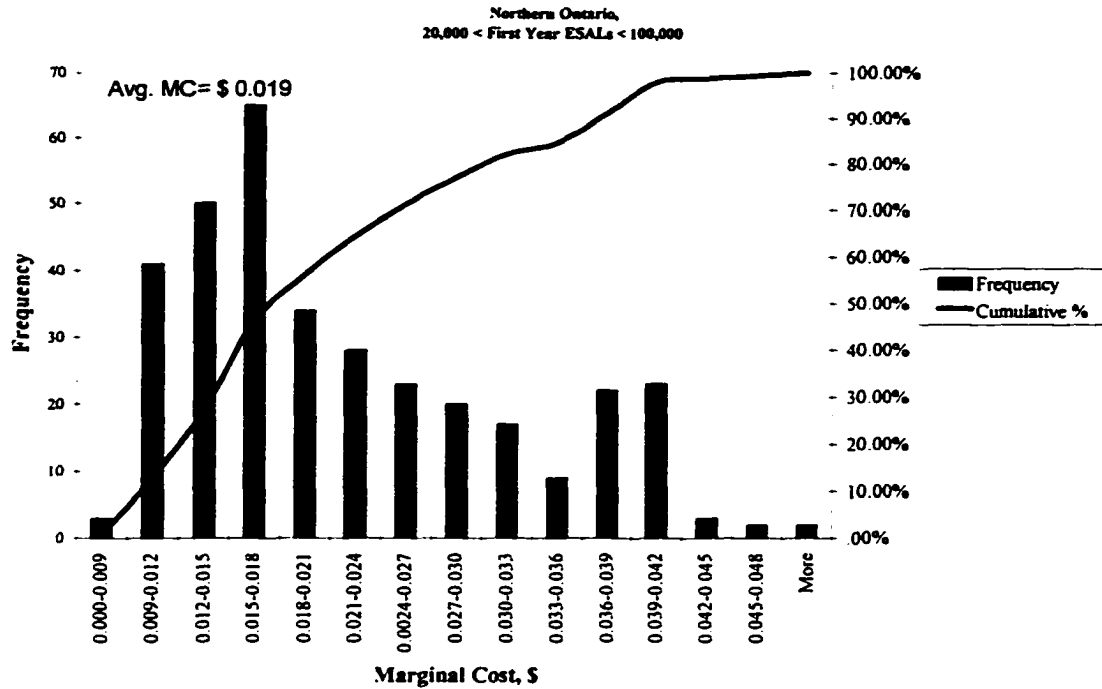

Figure B.2. Frequency Distribution of Marginal Cost for Road Class 2

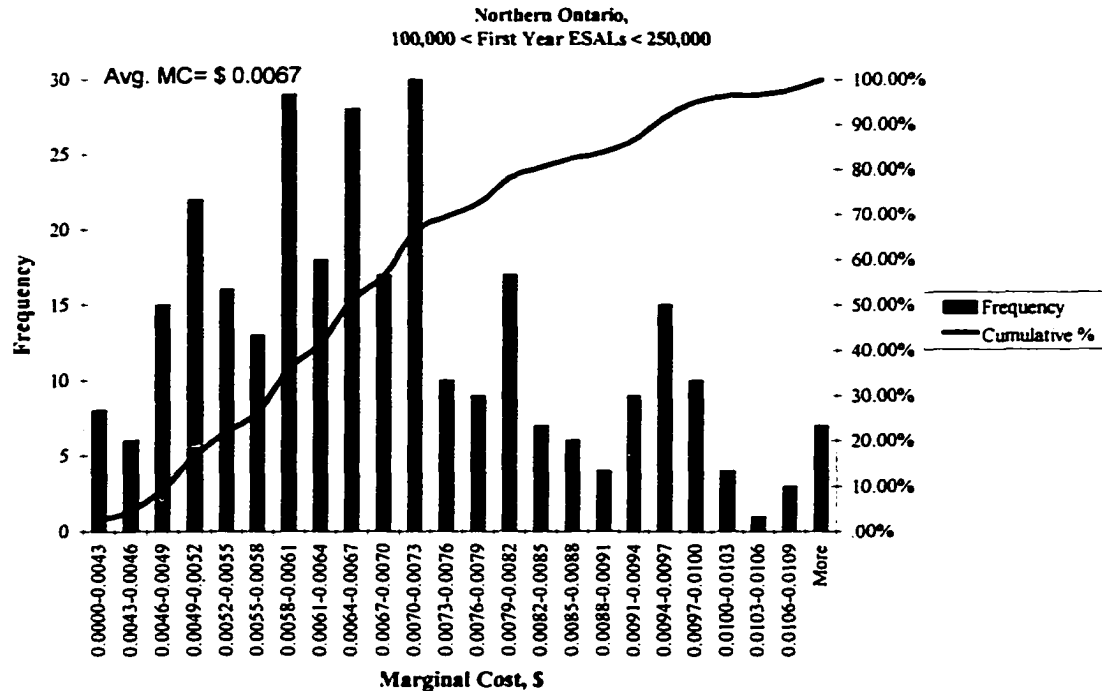

Figure B.3. Frequency Distribution of Marginal Cost for Road Class 3

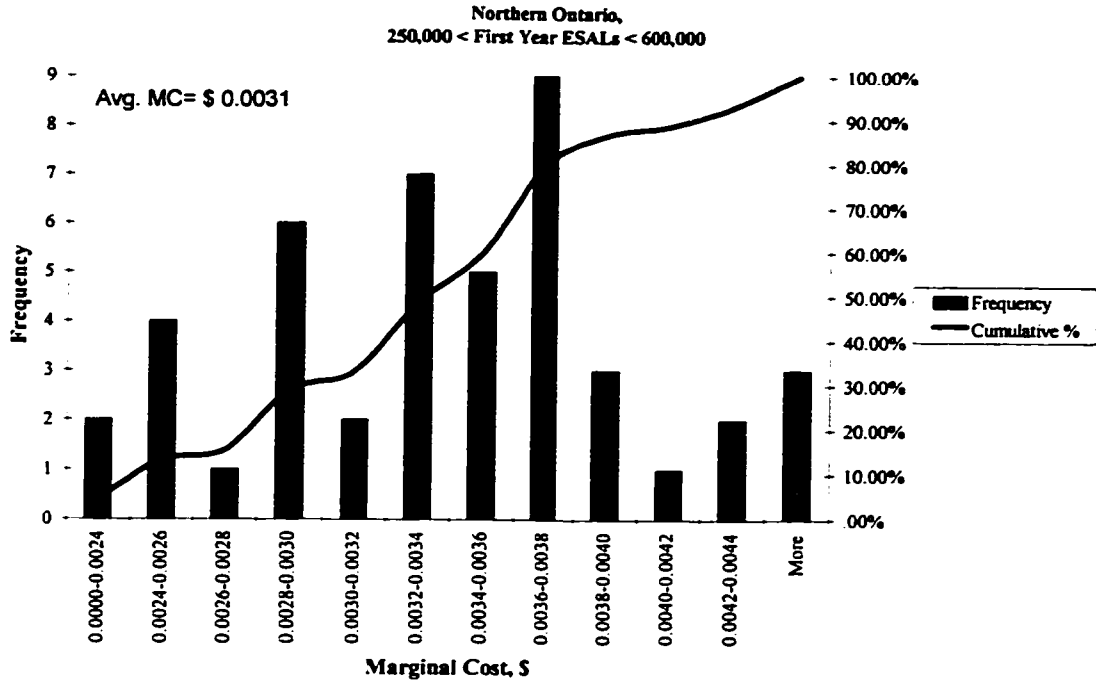

Figure B.4. Frequency Distribution of Marginal Cost for Road Class 4

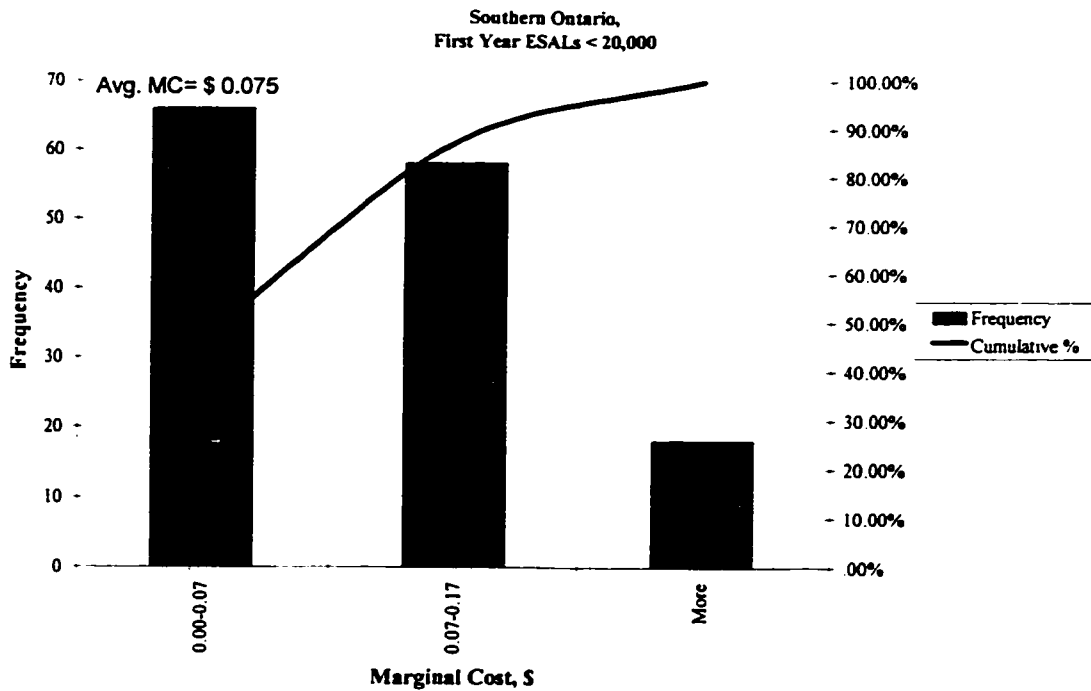

Figure B.5. Frequency Distribution of Marginal Cost for Road Class 5

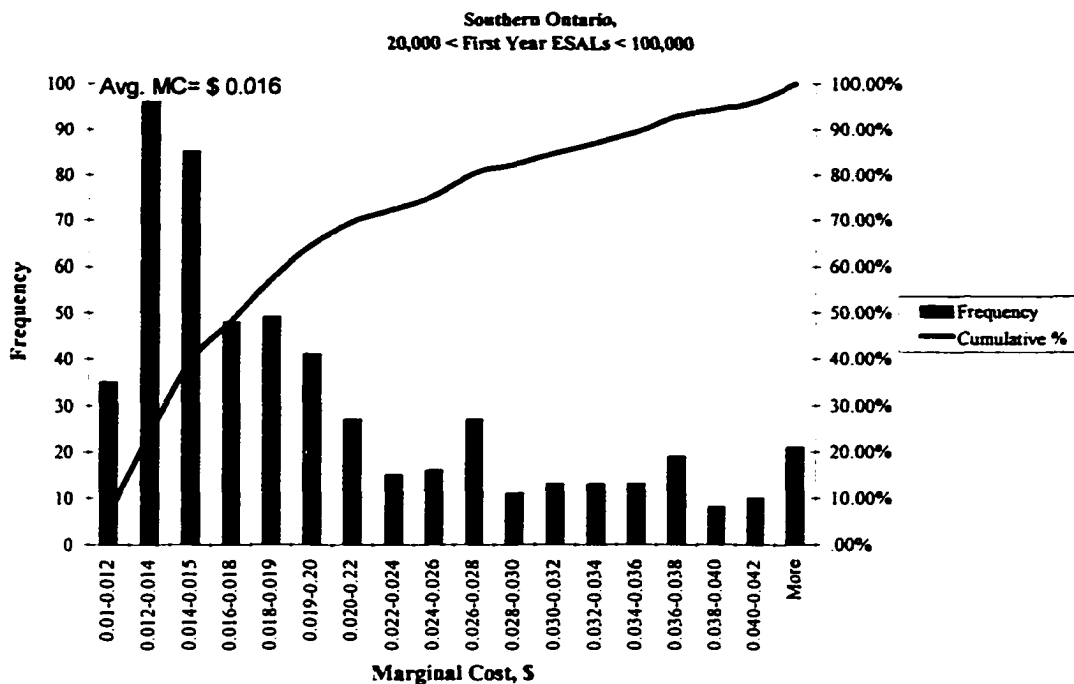

Figure B.6. Frequency Distribution of Marginal Cost for Road Class 6

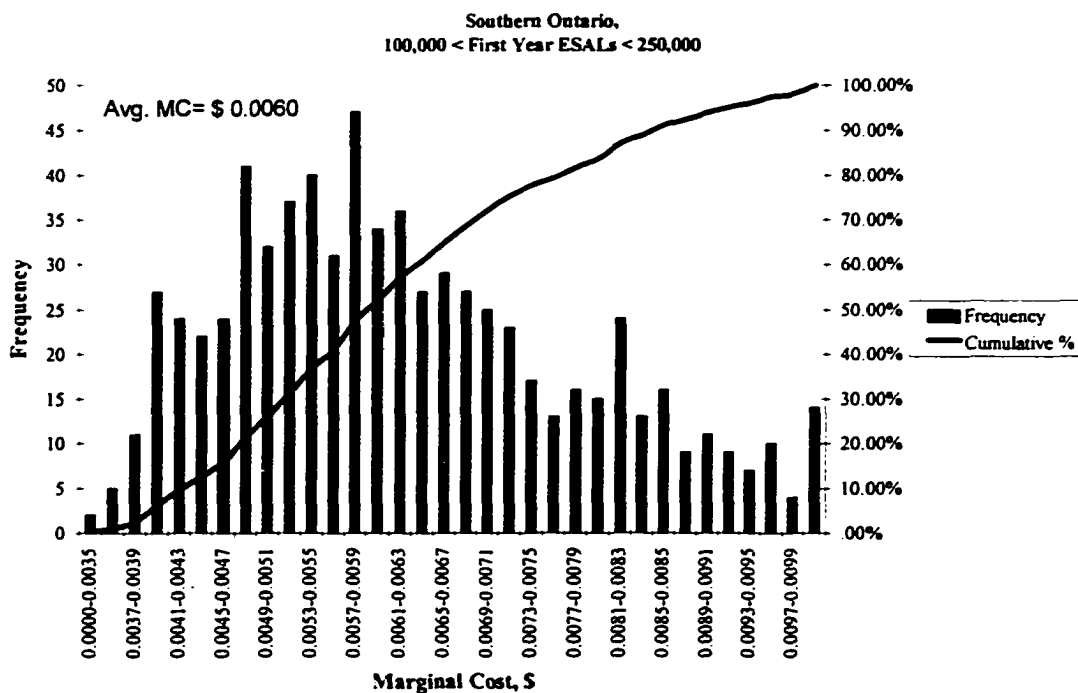

Figure B.7. Frequency Distribution of Marginal Cost for Road Class 7

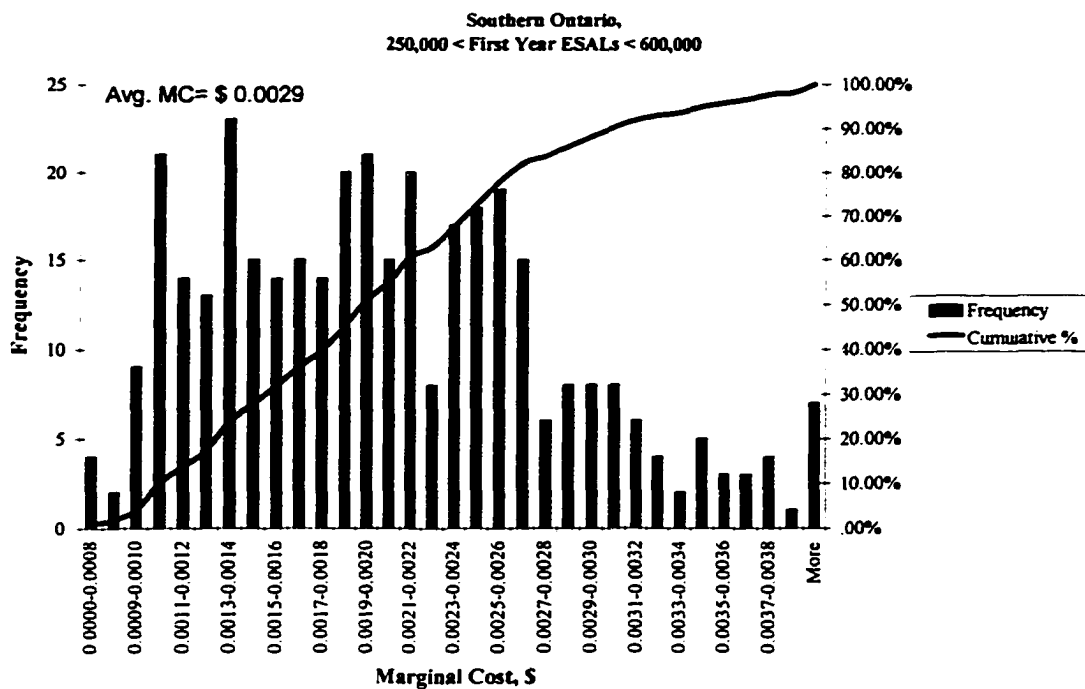

Figure B.8. Frequency Distribution of Marginal Cost for Road Class 8

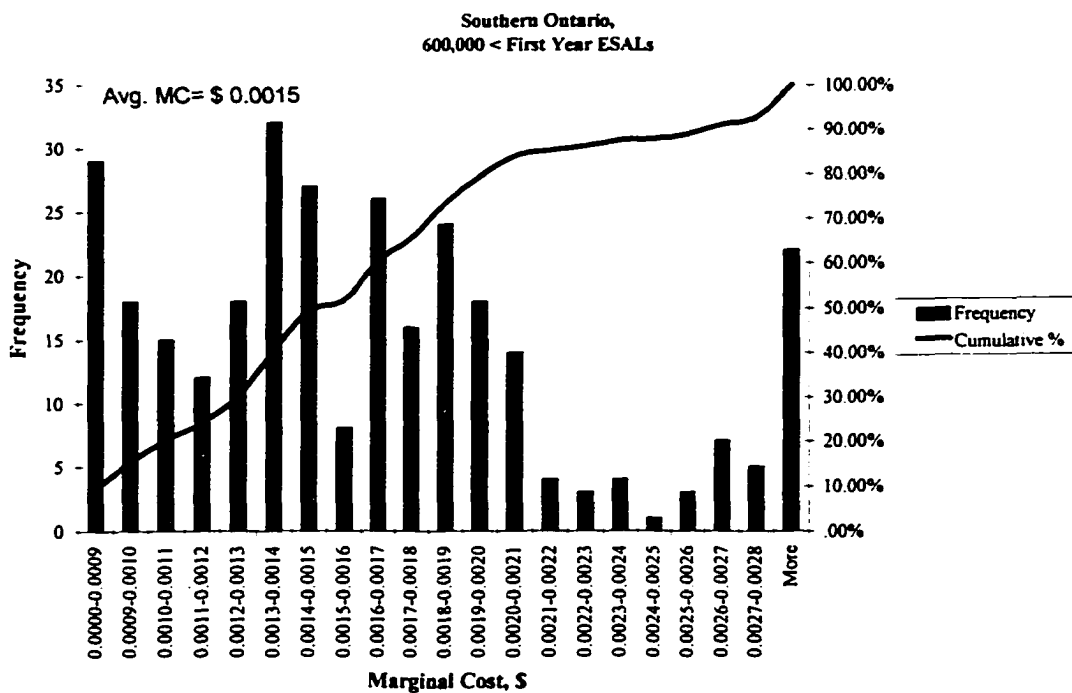

Figure B.9. Frequency Distribution of Marginal Cost for Road Class 9

APPENDIX C

The Source File of the Cost Allocation Programming

:objective function

MIN=1/93.7731418181818 * (T221 - 0.051575228) + 1/73.345676 * (T231 - 0.146691352) +
1/120.579773 * (T241 - 0.482319092) + 1/130.764054545455 * (T321 - 0.07192023) +
1/110.79603 * (T331 - 0.22159206) + 1/174.357963 * (T341 - 0.697431852) +
1/263.6297584 * (T351 - 1.318148792) + 1/126.051836363636 * (T421 - 0.06932851) +
1/81.4124045 * (T431 - 0.162824809) + 1/113.63072375 * (T441 - 0.454522895) +
1/172.6215106 * (T451 - 0.863107553) + 1/107.791990909091 * (T521 - 0.059285595) +
1/78.4319265 * (T531 - 0.156863853) + 1/99.37626375 * (T541 - 0.397505055) +
1/139.4474946 * (T551 - 0.697237473) + 1/110.737127272727 * (T621 - 0.06090542) +
1/75.7754135 * (T631 - 0.151550827) + 1/102.3405435 * (T641 - 0.409362174) +
1/145.0456098 * (T651 - 0.725228049) + 1/76.8091563636364 * (T721 - 0.042245036) +
1/291.0177595 * (T731 - 0.582035519) + 1/30.3938072727273 * (T821 - 0.016716594) +
1/72.6653495 * (T831 - 0.145330699) + 1/172.81912925 * (T841 - 0.691276517) +
1/279.1541612 * (T851 - 1.395770806) + 1/27.5994909090909 * (T222 - 0.01517972) +
1/21.58724 * (T232 - 0.04317448) + 1/35.48927 * (T242 - 0.14195708) +
1/38.4867272727273 * (T322 - 0.0211677) + 1/32.6097 * (T332 - 0.0652194) +
1/51.31737 * (T342 - 0.20526948) + 1/77.592016 * (T352 - 0.38796008) +
1/37.0998181818182 * (T422 - 0.0204049) + 1/23.961455 * (T432 - 0.04792291) +
1/33.4440125 * (T442 - 0.13377605) + 1/50.806294 * (T452 - 0.25403147) +
1/31.7255454545455 * (T522 - 0.01744905) + 1/23.084235 * (T532 - 0.04616847) +
1/29.2486125 * (T542 - 0.11699445) + 1/41.042454 * (T552 - 0.20521227) +
1/32.5923636363636 * (T622 - 0.0179258) + 1/22.302365 * (T632 - 0.04460473) +
1/30.121065 * (T642 - 0.12048426) + 1/42.690102 * (T652 - 0.21345051) +
1/22.6066181818182 * (T722 - 0.01243364) + 1/85.652905 * (T732 - 0.17130581) +
1/8.94556363636364 * (T822 - 0.00492006) + 1/21.387005 * (T832 - 0.04277401) +
1/50.8644575 * (T842 - 0.20345783) + 1/82.161188 * (T852 - 0.41080594) +
1/9.75172363636364 * (T223 - 0.005363448) + 1/7.627416 * (T233 - 0.015254832) +
1/12.539418 * (T243 - 0.050157672) + 1/13.5985090909091 * (T323 - 0.00747918) +
1/11.52198 * (T333 - 0.02304396) + 1/18.131958 * (T343 - 0.072527832) +
1/27.4155744 * (T353 - 0.137077872) + 1/13.1084727272727 * (T423 - 0.00720966) +
1/8.466297 * (T433 - 0.016932594) + 1/11.8167675 * (T443 - 0.04726707) +
1/17.9513796 * (T453 - 0.089756898) + 1/11.2095818181818 * (T523 - 0.00616527) +
1/8.156349 * (T533 - 0.016312698) + 1/10.3344075 * (T543 - 0.04133763) +
1/14.5015236 * (T553 - 0.072507618) + 1/11.5158545454545 * (T623 - 0.00633372) +
1/7.880091 * (T633 - 0.015760182) + 1/10.642671 * (T643 - 0.042570684) +
1/15.0836868 * (T653 - 0.075418434) + 1/7.98759272727273 * (T723 - 0.004393176) +
1/30.263727 * (T733 - 0.060527454) + 1/3.16073454545455 * (T823 - 0.001738404) +
1/7.556667 * (T833 - 0.015113334) + 1/17.9719305 * (T843 - 0.071887722) +
1/29.0299992 * (T853 - 0.145149996) + 1/4.42865454545455 * (T224 - 0.00243576) +
1/3.46392 * (T234 - 0.00692784) + 1/5.69466 * (T244 - 0.02277864) +
1/6.17563636363636 * (T324 - 0.0033966) + 1/5.2326 * (T334 - 0.0104652) +
1/8.23446 * (T344 - 0.03293784) + 1/12.450528 * (T354 - 0.06225264) +
1/5.95309090909091 * (T424 - 0.0032742) + 1/3.84489 * (T434 - 0.00768978) +
1/5.366475 * (T444 - 0.0214659) + 1/8.152452 * (T454 - 0.04076226) +
1/5.09072727272727 * (T524 - 0.0027999) + 1/3.70413 * (T534 - 0.00740826) +
1/4.693275 * (T544 - 0.0187731) + 1/6.585732 * (T554 - 0.03292866) +
1/5.22981818181818 * (T624 - 0.0028764) + 1/3.57867 * (T634 - 0.00715734) +
1/4.83327 * (T644 - 0.01933308) + 1/6.850116 * (T654 - 0.03425058) +

$1/3.62749090909091 * (T724 - 0.00199512) + 1/13.74399 * (T734 - 0.02748798) +$
 $1/1.43541818181818 * (T824 - 0.00078948) + 1/3.43179 * (T834 - 0.00686358) +$
 $1/8.161785 * (T844 - 0.03264714) + 1/13.183704 * (T854 - 0.06591852) +$
 $1/107.918785454545 * (T225 - 0.059355332) + 1/84.409844 * (T235 - 0.168819688) +$
 $1/138.769187 * (T245 - 0.555076748) + 1/150.489763636364 * (T325 - 0.08276937) +$
 $1/127.50957 * (T335 - 0.25501914) + 1/200.659797 * (T345 - 0.802639188) +$
 $1/303.3982096 * (T355 - 1.516991048) + 1/145.066709090909 * (T425 - 0.07978669) +$
 $1/93.6934355 * (T435 - 0.187386871) + 1/130.77187625 * (T445 - 0.523087505) +$
 $1/198.6614014 * (T455 - 0.993307007) + 1/124.052372727273 * (T525 - 0.068228805) +$
 $1/90.2633535 * (T535 - 0.180526707) + 1/114.36713625 * (T545 - 0.457468545) +$
 $1/160.4830974 * (T555 - 0.802415487) + 1/127.441781818182 * (T625 - 0.07009298) +$
 $1/87.2061065 * (T635 - 0.174412213) + 1/117.7785765 * (T645 - 0.471114306) +$
 $1/166.9256862 * (T655 - 0.834628431) + 1/88.3957890909091 * (T725 - 0.048617684) +$
 $1/334.9176805 * (T735 - 0.669835361) + 1/34.9787018181818 * (T825 - 0.019238286) +$
 $1/83.6268905 * (T835 - 0.167253781) + 1/198.88883075 * (T845 - 0.795555323) +$
 $1/321.2644628 * (T855 - 1.606322314) + 1/23.2692509090909 * (T226 - 0.012798088) +$
 $1/18.200296 * (T236 - 0.036400592) + 1/29.921158 * (T246 - 0.119684632) +$
 $1/32.4483272727273 * (T326 - 0.01784658) + 1/27.49338 * (T336 - 0.05498676) +$
 $1/43.265898 * (T346 - 0.173063592) + 1/65.4181664 * (T356 - 0.327090832) +$
 $1/31.2790181818182 * (T426 - 0.01720346) + 1/20.202007 * (T436 - 0.040404014) +$
 $1/28.1967925 * (T446 - 0.11278717) + 1/42.8350076 * (T456 - 0.214175038) +$
 $1/26.7479454545455 * (T526 - 0.01471137) + 1/19.462419 * (T536 - 0.038924838) +$
 $1/24.6596325 * (T546 - 0.09863853) + 1/34.6030716 * (T556 - 0.173015358) +$
 $1/27.4787636363636 * (T626 - 0.01511332) + 1/18.803221 * (T636 - 0.037606442) +$
 $1/25.395201 * (T646 - 0.101580804) + 1/35.9922108 * (T656 - 0.179961054) +$
 $1/19.0597381818182 * (T726 - 0.010482856) + 1/72.214337 * (T736 - 0.144428674) +$
 $1/7.54204363636364 * (T826 - 0.004148124) + 1/18.031477 * (T836 - 0.036062954) +$
 $1/42.8840455 * (T846 - 0.171536182) + 1/69.2704552 * (T856 - 0.346352276) +$
 $1/8.70245090909091 * (T227 - 0.004786348) + 1/6.806716 * (T237 - 0.013613432) +$
 $1/11.190193 * (T247 - 0.044760772) + 1/12.1353272727273 * (T327 - 0.00667443) +$
 $1/10.28223 * (T337 - 0.02056446) + 1/16.180983 * (T347 - 0.064723932) +$
 $1/24.4656944 * (T357 - 0.122328472) + 1/11.6980181818182 * (T427 - 0.00643391) +$
 $1/7.5553345 * (T437 - 0.015110669) + 1/10.54529875 * (T447 - 0.042181195) +$
 $1/16.0198346 * (T457 - 0.080099173) + 1/10.0034454545455 * (T527 - 0.005501895) +$
 $1/7.2787365 * (T537 - 0.014557473) + 1/9.22243875 * (T547 - 0.036889755) +$
 $1/12.9411786 * (T557 - 0.064705893) + 1/10.2767636363636 * (T627 - 0.00565222) +$
 $1/7.0322035 * (T637 - 0.014064407) + 1/9.4975335 * (T647 - 0.037990134) +$
 $1/13.4607018 * (T657 - 0.067303509) + 1/7.12813818181818 * (T727 - 0.003920476) +$
 $1/27.0073895 * (T737 - 0.054014779) + 1/2.82064363636364 * (T827 - 0.001551354) +$
 $1/6.7435795 * (T837 - 0.013487159) + 1/16.03817425 * (T847 - 0.064152697) +$
 $1/25.9064092 * (T857 - 0.129532046) + 1/4.26511272727273 * (T228 - 0.002345812) +$
 $1/3.336004 * (T238 - 0.006672008) + 1/5.484367 * (T248 - 0.021937468) +$
 $1/5.94758181818182 * (T328 - 0.00327117) + 1/5.03937 * (T338 - 0.01007874) +$
 $1/7.930377 * (T348 - 0.031721508) + 1/11.9907536 * (T358 - 0.059953768) +$
 $1/5.73325454545455 * (T428 - 0.00315329) + 1/3.7029055 * (T438 - 0.007405811) +$
 $1/5.16830125 * (T448 - 0.020673205) + 1/7.8513974 * (T458 - 0.039256987) +$
 $1/4.90273636363636 * (T528 - 0.002696505) + 1/3.5673435 * (T538 - 0.007134687) +$
 $1/4.51996125 * (T548 - 0.018079845) + 1/6.3425334 * (T558 - 0.031712667) +$
 $1/5.03669090909091 * (T628 - 0.00277018) + 1/3.4465165 * (T638 - 0.006893033) +$
 $1/4.6547865 * (T648 - 0.018619146) + 1/6.5971542 * (T658 - 0.032985771) +$
 $1/3.49353454545455 * (T728 - 0.001921444) + 1/13.2364505 * (T738 - 0.026472901) +$
 $1/1.38241090909091 * (T828 - 0.000760326) + 1/3.3050605 * (T838 - 0.006610121) +$
 $1/7.86038575 * (T848 - 0.031441543) + 1/12.6968548 * (T858 - 0.063484274) +$
 $1/2.15788363636364 * (T229 - 0.001186836) + 1/1.687812 * (T239 - 0.003375624) +$
 $1/2.774751 * (T249 - 0.011099004) + 1/3.00910909090909 * (T329 - 0.00165501) +$

$1/2.54961 * (T339 - 0.00509922) + 1/4.012281 * (T349 - 0.016049124) +$
 $1/6.0665808 * (T359 - 0.030332904) + 1/2.90067272727273 * (T429 - 0.00159537) +$
 $1/1.8734415 * (T439 - 0.003746883) + 1/2.61484125 * (T449 - 0.010459365) +$
 $1/3.9723222 * (T459 - 0.019861611) + 1/2.48048181818182 * (T529 - 0.001364265) +$
 $1/1.8048555 * (T539 - 0.003609711) + 1/2.28682125 * (T549 - 0.009147285) +$
 $1/3.2089302 * (T559 - 0.016044651) + 1/2.54825454545455 * (T629 - 0.00140154) +$
 $1/1.7437245 * (T639 - 0.003487449) + 1/2.3550345 * (T649 - 0.009420138) +$
 $1/3.3377526 * (T659 - 0.016688763) + 1/1.76751272727273 * (T729 - 0.000972132) +$
 $1/6.6968265 * (T739 - 0.013393653) + 1/0.699414545454546 * (T829 - 0.000384678) +$
 $1/1.6721565 * (T839 - 0.003344313) + 1/3.97686975 * (T849 - 0.015907479) +$
 $1/6.4238244 * (T859 - 0.032119122);$

: s.t.

$T859 - T359 > 0.001786218 ;$
 $T359 - T459 > 0.010471293 ;$
 $T459 - T659 > 0.003172848 ;$
 $T659 - T559 > 0.000644112000000002 ;$
 $T349 - T849 > 0.000141644999999999 ;$
 $T849 - T249 > 0.004808475 ;$
 $T249 - T449 > 0.000639639000000001 ;$
 $T449 - T649 > 0.001039227 ;$
 $T649 - T549 > 0.000272853 ;$
 $T739 - T339 > 0.008294433 ;$
 $T339 - T439 > 0.001352337 ;$
 $T439 - T539 > 0.000137172 ;$
 $T539 - T639 > 0.000122262 ;$
 $T639 - T239 > 0.000111825 ;$
 $T239 - T839 > 3.131099999999999E-05 ;$
 $T329 - T429 > 5.96400000000001E-05 ;$
 $T429 - T629 > 0.00019383 ;$
 $T629 - T529 > 0.000037275 ;$
 $T529 - T229 > 0.000177429 ;$
 $T229 - T729 > 0.000214704 ;$
 $T729 - T829 > 0.000587454 ;$
 $T419 - T319 > 0.000093933 ;$
 $T319 - T619 > 9.691499999999999E-05 ;$
 $T619 - T519 > 4.920299999999999E-05 ;$
 $T519 - T219 > 4.77120000000001E-05 ;$
 $T219 - T819 > 0.000752955 ;$
 $T819 - T719 > 5.963999999999999E-06 ;$
 $T719 - T119 > 0.0001653519 ;$
 $T858 - T358 > 0.003530506 ;$
 $T358 - T458 > 0.020696781 ;$
 $T458 - T658 > 0.006271216 ;$
 $T658 - T558 > 0.001273104 ;$
 $T348 - T848 > 0.000279964999999993 ;$
 $T848 - T248 > 0.009504075 ;$
 $T248 - T448 > 0.001264263 ;$
 $T448 - T648 > 0.002054059 ;$
 $T648 - T548 > 0.000539300999999999 ;$
 $T738 - T338 > 0.016394161 ;$
 $T338 - T438 > 0.002672929 ;$
 $T438 - T538 > 0.000271124 ;$
 $T538 - T638 > 0.000241654 ;$
 $T638 - T238 > 0.000221025000000001 ;$

T238 - T838 > 6.18870000000001E-05 ;
 T328 - T428 > 0.00011788 ;
 T428 - T628 > 0.00038311 ;
 T628 - T528 > 7.36749999999996E-05 ;
 T528 - T228 > 0.000350693 ;
 T228 - T728 > 0.000424368 ;
 T728 - T828 > 0.001161118 ;
 T418 - T318 > 0.000185661 ;
 T318 - T618 > 0.000191555 ;
 T618 - T518 > 0.000097251 ;
 T518 - T218 > 9.43040000000001E-05 ;
 T218 - T818 > 0.001488235 ;
 T818 - T718 > 0.000011788 ;
 T718 - T118 > 0.0003268223 ;
 T857 - T357 > 0.007203574 ;
 T357 - T457 > 0.042229299 ;
 T457 - T657 > 0.012795664 ;
 T657 - T557 > 0.002597616 ;
 T347 - T847 > 0.000571234999999989 ;
 T847 - T247 > 0.019391925 ;
 T247 - T447 > 0.002579577 ;
 T447 - T647 > 0.004191061 ;
 T647 - T547 > 0.001100379000000001 ;
 T737 - T337 > 0.033450319 ;
 T337 - T437 > 0.005453791 ;
 T437 - T537 > 0.000553196000000001 ;
 T537 - T637 > 0.000493066 ;
 T637 - T237 > 0.000450975000000001 ;
 T237 - T837 > 0.000126272999999998 ;
 T327 - T427 > 0.00024052 ;
 T427 - T627 > 0.000781690000000001 ;
 T627 - T527 > 0.000150324999999999 ;
 T527 - T227 > 0.000715547 ;
 T227 - T727 > 0.000865872 ;
 T727 - T827 > 0.002369122 ;
 T417 - T317 > 0.000378819 ;
 T317 - T617 > 0.000390844999999999 ;
 T617 - T517 > 0.000198429000000001 ;
 T517 - T217 > 0.000192416 ;
 T217 - T817 > 0.003036565 ;
 T817 - T717 > 2.40520000000001E-05 ;
 T717 - T117 > 0.0006668417 ;
 T856 - T356 > 0.019261444 ;
 T356 - T456 > 0.112915794 ;
 T456 - T656 > 0.034213984 ;
 T656 - T556 > 0.006945696 ;
 T346 - T846 > 0.001527409999999998 ;
 T846 - T246 > 0.05185155 ;
 T246 - T446 > 0.006897462000000001 ;
 T446 - T646 > 0.011206366 ;
 T646 - T546 > 0.002942273999999999 ;
 T736 - T336 > 0.089441914 ;
 T336 - T436 > 0.014582746 ;
 T436 - T536 > 0.001479176 ;
 T536 - T636 > 0.001318396 ;

T636 - T236 > 0.00120585 ;
 T236 - T836 > 0.000337638000000001 ;
 T326 - T426 > 0.00064312 ;
 T426 - T626 > 0.00209014 ;
 T626 - T526 > 0.0004019499999999998 ;
 T526 - T226 > 0.001913282 ;
 T226 - T726 > 0.002315232 ;
 T726 - T826 > 0.006334732 ;
 T416 - T316 > 0.001012914 ;
 T316 - T616 > 0.00104507 ;
 T616 - T516 > 0.0005305740000000001 ;
 T516 - T216 > 0.000514496 ;
 T216 - T816 > 0.00811939 ;
 T816 - T716 > 0.000064312 ;
 T716 - T116 > 0.0017830502 ;
 T855 - T355 > 0.08933126600000001 ;
 T355 - T455 > 0.523684041 ;
 T455 - T655 > 0.158678576 ;
 T655 - T555 > 0.03221294400000001 ;
 T345 - T845 > 0.007083864999999991 ;
 T845 - T245 > 0.240478575 ;
 T245 - T445 > 0.03198924300000001 ;
 T445 - T645 > 0.051973199 ;
 T645 - T545 > 0.013645761 ;
 T735 - T335 > 0.414816221 ;
 T335 - T435 > 0.067632269 ;
 T435 - T535 > 0.006860164 ;
 T535 - T635 > 0.006114494 ;
 T635 - T235 > 0.005592525000000001 ;
 T235 - T835 > 0.001565906999999998 ;
 T325 - T425 > 0.00298268 ;
 T425 - T625 > 0.009693710000000001 ;
 T625 - T525 > 0.001864174999999998 ;
 T525 - T225 > 0.008873473000000001 ;
 T225 - T725 > 0.010737648 ;
 T725 - T825 > 0.029379398 ;
 T415 - T315 > 0.004697720999999999 ;
 T315 - T615 > 0.004846855 ;
 T615 - T515 > 0.002460711 ;
 T515 - T215 > 0.002386144000000001 ;
 T215 - T815 > 0.037656335 ;
 T815 - T715 > 0.0002982679999999999 ;
 T715 - T115 > 0.0082694803 ;
 T854 - T354 > 0.00366588 ;
 T354 - T454 > 0.02149038 ;
 T454 - T654 > 0.00651168 ;
 T654 - T554 > 0.00132192 ;
 T344 - T844 > 0.0002906999999999998 ;
 T844 - T244 > 0.0098685 ;
 T244 - T444 > 0.00131274 ;
 T444 - T644 > 0.00213282 ;
 T644 - T544 > 0.0005599800000000002 ;
 T734 - T334 > 0.01702278 ;
 T334 - T434 > 0.00277542 ;
 T434 - T534 > 0.00028152 ;

T534 - T634 > 0.00025092 ;
 T634 - T234 > 0.000229500000000001 ;
 T234 - T834 > 6.425999999999991E-05 ;
 T324 - T424 > 0.0001224 ;
 T424 - T624 > 0.000397800000000001 ;
 T624 - T524 > 7.649999999999997E-05 ;
 T524 - T224 > 0.00036414 ;
 T224 - T724 > 0.00044064 ;
 T724 - T824 > 0.00120564 ;
 T414 - T314 > 0.00019278 ;
 T314 - T614 > 0.0001989 ;
 T614 - T514 > 0.00010098 ;
 T514 - T214 > 0.00009792 ;
 T214 - T814 > 0.0015453 ;
 T814 - T714 > 0.00001224 ;
 T714 - T114 > 0.000339354 ;
 T853 - T353 > 0.008072123999999999 ;
 T353 - T453 > 0.047320974 ;
 T453 - T653 > 0.014338464 ;
 T653 - T553 > 0.002910816 ;
 T343 - T843 > 0.0006401099999999999 ;
 T843 - T243 > 0.02173005 ;
 T243 - T443 > 0.002890602 ;
 T443 - T643 > 0.004696386 ;
 T643 - T543 > 0.001233054 ;
 T733 - T333 > 0.037483494 ;
 T333 - T433 > 0.006111366 ;
 T433 - T533 > 0.0006198959999999998 ;
 T533 - T633 > 0.0005525159999999999 ;
 T633 - T233 > 0.0005053500000000002 ;
 T233 - T833 > 0.000141498 ;
 T323 - T423 > 0.0002695200000000001 ;
 T423 - T623 > 0.0008759400000000001 ;
 T623 - T523 > 0.0001684499999999999 ;
 T523 - T223 > 0.000801822 ;
 T223 - T723 > 0.000970272 ;
 T723 - T823 > 0.002654772 ;
 T413 - T313 > 0.000424494 ;
 T313 - T613 > 0.0004379699999999999 ;
 T613 - T513 > 0.000222354 ;
 T513 - T213 > 0.000215616 ;
 T213 - T813 > 0.00340269 ;
 T813 - T713 > 2.695200000000001E-05 ;
 T713 - T113 > 0.0007472442 ;
 T852 - T352 > 0.02284586 ;
 T352 - T452 > 0.13392861 ;
 T452 - T652 > 0.04058096 ;
 T652 - T552 > 0.008238240000000001 ;
 T342 - T842 > 0.001811649999999997 ;
 T842 - T242 > 0.06150075 ;
 T242 - T442 > 0.008181030000000001 ;
 T442 - T642 > 0.01329179 ;
 T642 - T542 > 0.00348981 ;
 T732 - T332 > 0.10608641 ;
 T332 - T432 > 0.01729649 ;

T432 - T532 > 0.00175444 ;
 T532 - T632 > 0.00156373999999999 ;
 T632 - T232 > 0.00143025000000001 ;
 T232 - T832 > 0.000400469999999993 ;
 T322 - T422 > 0.000762800000000001 ;
 T422 - T622 > 0.0024791 ;
 T622 - T522 > 0.000476749999999998 ;
 T522 - T222 > 0.00226933 ;
 T222 - T722 > 0.00274608 ;
 T722 - T822 > 0.00751358 ;
 T412 - T312 > 0.00120141 ;
 T312 - T612 > 0.00123955 ;
 T612 - T512 > 0.000629309999999999 ;
 T512 - T212 > 0.000610240000000001 ;
 T212 - T812 > 0.00963035 ;
 T812 - T712 > 7.62800000000002E-05 ;
 T712 - T112 > 0.002114863 ;
 T851 - T351 > 0.0776220140000001 ;
 T351 - T451 > 0.455041239 ;
 T451 - T651 > 0.137879504 ;
 T651 - T551 > 0.0279905760000001 ;
 T341 - T841 > 0.006155334999999998 ;
 T841 - T241 > 0.208957425 ;
 T241 - T441 > 0.027796197 ;
 T441 - T641 > 0.045160721 ;
 T641 - T541 > 0.011857119 ;
 T731 - T331 > 0.360443459 ;
 T331 - T431 > 0.058767251 ;
 T431 - T531 > 0.005960956000000002 ;
 T531 - T631 > 0.005313026 ;
 T631 - T231 > 0.004859475 ;
 T231 - T831 > 0.001360652999999999 ;
 T321 - T421 > 0.00259172000000001 ;
 T421 - T621 > 0.008423090000000001 ;
 T621 - T521 > 0.001619825 ;
 T521 - T221 > 0.007710367 ;
 T221 - T721 > 0.009330192 ;
 T721 - T821 > 0.025528442 ;
 T411 - T311 > 0.004081959 ;
 T311 - T611 > 0.004211545 ;
 T611 - T511 > 0.002138169 ;
 T511 - T211 > 0.002073376 ;
 T211 - T811 > 0.032720465 ;
 T811 - T711 > 0.000259172 ;
 T711 - T111 > 0.0071855437 ;
 1 / 11.26295 * (0.2871 * T219 + 0.2649 * T229 + 0.4057 * T239 + 0.0423 * T249) - 1 / 23.86835 * (0.2636 * T519 + 0.0797 * T529 + 0.2058 * T539 + 0.387 * T549 + 0.0639 * T559) < 0 ;
 1 / 23.86835 * (0.2636 * T519 + 0.0797 * T529 + 0.2058 * T539 + 0.387 * T549 + 0.0639 * T559) - 1 / 29.489045 * (0.1774 * T619 + 0.02419 * T629 + 0.1774 * T639 + 0.5726 * T649 + 0.0484 * T659) < 0 ;
 1 / 29.489045 * (0.1774 * T619 + 0.02419 * T629 + 0.1774 * T639 + 0.5726 * T649 + 0.0484 * T659) - 1 / 24.836265 * (0.266504 * T419 + 0.03423 * T429 + 0.1858 * T439 + 0.4939 * T449 + 0.0196 * T459) < 0 ;
 1 / 24.836265 * (0.266504 * T419 + 0.03423 * T429 + 0.1858 * T439 + 0.4939 * T449 + 0.0196 * T459) - 1 / 14.9281 * (0.3522 * T819 + 0.1822 * T829 + 0.247 * T839 + 0.2065 * T849 + 0.0121 * T859) < 0 ;

$1 / 14.9281 * (0.3522 * T819 + 0.1822 * T829 + 0.247 * T839 + 0.2065 * T849 + 0.0121 * T859) - 1 / 20.22095 * (0.1676 * T319 + 0.1529 * T329 + 0.4029 * T339 + 0.2637 * T349 + 0.0129 * T359) < 0;$
 $1 / 20.22095 * (0.1676 * T319 + 0.1529 * T329 + 0.4029 * T339 + 0.2637 * T349 + 0.0129 * T359) - 1 / 3.12405 * (0.611 * T719 + 0.3211 * T729 + 0.0679 * T739) < 0;$
 $1 / 3.12405 * (0.611 * T719 + 0.3211 * T729 + 0.0679 * T739) - 1 / 11.26295 * (0.2871 * T218 + 0.2649 * T228 + 0.4057 * T238 + 0.0423 * T248) < 0;$
 $1 / 11.26295 * (0.2871 * T218 + 0.2649 * T228 + 0.4057 * T238 + 0.0423 * T248) - 1 / 11.26295 * (0.2871 * T214 + 0.2649 * T224 + 0.4057 * T234 + 0.0423 * T244) < 0;$
 $1 / 11.26295 * (0.2871 * T214 + 0.2649 * T224 + 0.4057 * T234 + 0.0423 * T244) - 1 / 23.86835 * (0.2636 * T518 + 0.0797 * T528 + 0.2058 * T538 + 0.387 * T548 + 0.0639 * T558) < 0;$
 $1 / 23.86835 * (0.2636 * T518 + 0.0797 * T528 + 0.2058 * T538 + 0.387 * T548 + 0.0639 * T558) - 1 / 29.489045 * (0.1774 * T618 + 0.02419 * T628 + 0.1774 * T638 + 0.5726 * T648 + 0.0484 * T658) < 0;$
 $1 / 29.489045 * (0.1774 * T618 + 0.02419 * T628 + 0.1774 * T638 + 0.5726 * T648 + 0.0484 * T658) - 1 / 23.86835 * (0.2636 * T514 + 0.0797 * T524 + 0.2058 * T534 + 0.387 * T544 + 0.0639 * T554) < 0;$
 $1 / 23.86835 * (0.2636 * T514 + 0.0797 * T524 + 0.2058 * T534 + 0.387 * T544 + 0.0639 * T554) - 1 / 29.489045 * (0.1774 * T614 + 0.02419 * T624 + 0.1774 * T634 + 0.5726 * T644 + 0.0484 * T654) < 0;$
 $1 / 29.489045 * (0.1774 * T614 + 0.02419 * T624 + 0.1774 * T634 + 0.5726 * T644 + 0.0484 * T654) - 1 / 24.836265 * (0.266504 * T418 + 0.03423 * T428 + 0.1858 * T438 + 0.4939 * T448 + 0.0196 * T458) < 0;$
 $1 / 24.836265 * (0.266504 * T418 + 0.03423 * T428 + 0.1858 * T438 + 0.4939 * T448 + 0.0196 * T458) - 1 / 24.836265 * (0.266504 * T414 + 0.03423 * T424 + 0.1858 * T434 + 0.4939 * T444 + 0.0196 * T454) < 0;$
 $1 / 24.836265 * (0.266504 * T414 + 0.03423 * T424 + 0.1858 * T434 + 0.4939 * T444 + 0.0196 * T454) - 1 / 14.9281 * (0.3522 * T818 + 0.1822 * T828 + 0.247 * T838 + 0.2065 * T848 + 0.0121 * T858) < 0;$
 $1 / 14.9281 * (0.3522 * T818 + 0.1822 * T828 + 0.247 * T838 + 0.2065 * T848 + 0.0121 * T858) - 1 / 14.9281 * (0.3522 * T814 + 0.1822 * T824 + 0.247 * T834 + 0.2065 * T844 + 0.0121 * T854) < 0;$
 $1 / 14.9281 * (0.3522 * T814 + 0.1822 * T824 + 0.247 * T834 + 0.2065 * T844 + 0.0121 * T854) - 1 / 20.22095 * (0.1676 * T318 + 0.1529 * T328 + 0.4029 * T338 + 0.2637 * T348 + 0.0129 * T358) < 0;$
 $1 / 20.22095 * (0.1676 * T318 + 0.1529 * T328 + 0.4029 * T338 + 0.2637 * T348 + 0.0129 * T358) - 1 / 20.22095 * (0.1676 * T314 + 0.1529 * T324 + 0.4029 * T334 + 0.2637 * T344 + 0.0129 * T354) < 0;$
 $1 / 20.22095 * (0.1676 * T314 + 0.1529 * T324 + 0.4029 * T334 + 0.2637 * T344 + 0.0129 * T354) - 1 / 3.12405 * (0.611 * T718 + 0.3211 * T728 + 0.0679 * T738) < 0;$
 $1 / 3.12405 * (0.611 * T718 + 0.3211 * T728 + 0.0679 * T738) - 1 / 11.26295 * (0.2871 * T217 + 0.2649 * T227 + 0.4057 * T237 + 0.0423 * T247) < 0;$
 $1 / 11.26295 * (0.2871 * T217 + 0.2649 * T227 + 0.4057 * T237 + 0.0423 * T247) - 1 / 3.12405 * (0.611 * T714 + 0.3211 * T724 + 0.0679 * T734) < 0;$
 $1 / 3.12405 * (0.611 * T714 + 0.3211 * T724 + 0.0679 * T734) - 1 / 23.86835 * (0.2636 * T517 + 0.0797 * T527 + 0.2058 * T537 + 0.387 * T547 + 0.0639 * T557) < 0;$
 $1 / 23.86835 * (0.2636 * T517 + 0.0797 * T527 + 0.2058 * T537 + 0.387 * T547 + 0.0639 * T557) - 1 / 29.489045 * (0.1774 * T617 + 0.02419 * T627 + 0.1774 * T637 + 0.5726 * T647 + 0.0484 * T657) < 0;$
 $1 / 29.489045 * (0.1774 * T617 + 0.02419 * T627 + 0.1774 * T637 + 0.5726 * T647 + 0.0484 * T657) - 1 / 11.26295 * (0.2871 * T213 + 0.2649 * T223 + 0.4057 * T233 + 0.0423 * T243) < 0;$
 $1 / 11.26295 * (0.2871 * T213 + 0.2649 * T223 + 0.4057 * T233 + 0.0423 * T243) - 1 / 23.86835 * (0.2636 * T513 + 0.0797 * T523 + 0.2058 * T533 + 0.387 * T543 + 0.0639 * T553) < 0;$
 $1 / 23.86835 * (0.2636 * T513 + 0.0797 * T523 + 0.2058 * T533 + 0.387 * T543 + 0.0639 * T553) - 1 / 24.836265 * (0.266504 * T417 + 0.03423 * T427 + 0.1858 * T437 + 0.4939 * T447 + 0.0196 * T457) < 0;$
 $1 / 24.836265 * (0.266504 * T417 + 0.03423 * T427 + 0.1858 * T437 + 0.4939 * T447 + 0.0196 * T457) - 1 / 29.489045 * (0.1774 * T613 + 0.02419 * T623 + 0.1774 * T633 + 0.5726 * T643 + 0.0484 * T653) < 0;$
 $1 / 29.489045 * (0.1774 * T613 + 0.02419 * T623 + 0.1774 * T633 + 0.5726 * T643 + 0.0484 * T653) - 1 / 24.836265 * (0.266504 * T413 + 0.03423 * T423 + 0.1858 * T433 + 0.4939 * T443 + 0.0196 * T453) < 0;$
 $1 / 24.836265 * (0.266504 * T413 + 0.03423 * T423 + 0.1858 * T433 + 0.4939 * T443 + 0.0196 * T453) - 1 / 14.9281 * (0.3522 * T817 + 0.1822 * T827 + 0.247 * T837 + 0.2065 * T847 + 0.0121 * T857) < 0;$
 $1 / 14.9281 * (0.3522 * T817 + 0.1822 * T827 + 0.247 * T837 + 0.2065 * T847 + 0.0121 * T857) - 1 / 14.9281 * (0.3522 * T813 + 0.1822 * T823 + 0.247 * T833 + 0.2065 * T843 + 0.0121 * T853) < 0;$

$$\begin{aligned}
& 1 / 14.9281 * (0.3522 * T813 + 0.1822 * T823 + 0.247 * T833 + 0.2065 * T843 + 0.0121 * T853) - 1 / \\
& 20.22095 * (0.1676 * T317 + 0.1529 * T327 + 0.4029 * T337 + 0.2637 * T347 + 0.0129 * T357) < 0; \\
& 1 / 20.22095 * (0.1676 * T317 + 0.1529 * T327 + 0.4029 * T337 + 0.2637 * T347 + 0.0129 * T357) - 1 / \\
& 20.22095 * (0.1676 * T313 + 0.1529 * T323 + 0.4029 * T333 + 0.2637 * T343 + 0.0129 * T353) < 0; \\
& 1 / 20.22095 * (0.1676 * T313 + 0.1529 * T323 + 0.4029 * T333 + 0.2637 * T343 + 0.0129 * T353) - 1 / \\
& 3.12405 * (0.611 * T717 + 0.3211 * T727 + 0.0679 * T737) < 0; \\
& 1 / 3.12405 * (0.611 * T717 + 0.3211 * T727 + 0.0679 * T737) - 1 / 3.12405 * (0.611 * T713 + 0.3211 * \\
& T723 + 0.0679 * T733) < 0; \\
& 1 / 3.12405 * (0.611 * T713 + 0.3211 * T723 + 0.0679 * T733) - 1 / 11.26295 * (0.2871 * T216 + \\
& 0.2649 * T226 + 0.4057 * T236 + 0.0423 * T246) < 0; \\
& 1 / 11.26295 * (0.2871 * T216 + 0.2649 * T226 + 0.4057 * T236 + 0.0423 * T246) - 1 / 23.86835 * (\\
& 0.2636 * T516 + 0.0797 * T526 + 0.2058 * T536 + 0.387 * T546 + 0.0639 * T556) < 0; \\
& 1 / 23.86835 * (0.2636 * T516 + 0.0797 * T526 + 0.2058 * T536 + 0.387 * T546 + 0.0639 * T556) - 1 / \\
& 29.489045 * (0.1774 * T616 + 0.02419 * T626 + 0.1774 * T636 + 0.5726 * T646 + 0.0484 * T656) < 0; \\
& 1 / 29.489045 * (0.1774 * T616 + 0.02419 * T626 + 0.1774 * T636 + 0.5726 * T646 + 0.0484 * T656) - \\
& 1 / 11.26295 * (0.2871 * T212 + 0.2649 * T222 + 0.4057 * T232 + 0.0423 * T242) < 0; \\
& 1 / 11.26295 * (0.2871 * T212 + 0.2649 * T222 + 0.4057 * T232 + 0.0423 * T242) - 1 / 24.836265 * (\\
& 0.266504 * T416 + 0.03423 * T426 + 0.1858 * T436 + 0.4939 * T446 + 0.0196 * T456) < 0; \\
& 1 / 24.836265 * (0.266504 * T416 + 0.03423 * T426 + 0.1858 * T436 + 0.4939 * T446 + 0.0196 * T456) \\
& - 1 / 23.86835 * (0.2636 * T512 + 0.0797 * T522 + 0.2058 * T532 + 0.387 * T542 + 0.0639 * T552) < 0; \\
& 1 / 23.86835 * (0.2636 * T512 + 0.0797 * T522 + 0.2058 * T532 + 0.387 * T542 + 0.0639 * T552) - 1 / \\
& 29.489045 * (0.1774 * T612 + 0.02419 * T622 + 0.1774 * T632 + 0.5726 * T642 + 0.0484 * T652) < 0; \\
& 1 / 29.489045 * (0.1774 * T612 + 0.02419 * T622 + 0.1774 * T632 + 0.5726 * T642 + 0.0484 * T652) - \\
& 1 / 14.9281 * (0.3522 * T816 + 0.1822 * T826 + 0.247 * T836 + 0.2065 * T846 + 0.0121 * T856) < 0; \\
& 1 / 14.9281 * (0.3522 * T816 + 0.1822 * T826 + 0.247 * T836 + 0.2065 * T846 + 0.0121 * T856) - 1 / \\
& 24.836265 * (0.266504 * T412 + 0.03423 * T422 + 0.1858 * T432 + 0.4939 * T442 + 0.0196 * T452) < \\
& 0; \\
& 1 / 24.836265 * (0.266504 * T412 + 0.03423 * T422 + 0.1858 * T432 + 0.4939 * T442 + 0.0196 * T452) \\
& - 1 / 20.22095 * (0.1676 * T316 + 0.1529 * T326 + 0.4029 * T336 + 0.2637 * T346 + 0.0129 * T356) < \\
& 0; \\
& 1 / 20.22095 * (0.1676 * T316 + 0.1529 * T326 + 0.4029 * T336 + 0.2637 * T346 + 0.0129 * T356) - 1 / \\
& 14.9281 * (0.3522 * T812 + 0.1822 * T822 + 0.247 * T832 + 0.2065 * T842 + 0.0121 * T852) < 0; \\
& 1 / 14.9281 * (0.3522 * T812 + 0.1822 * T822 + 0.247 * T832 + 0.2065 * T842 + 0.0121 * T852) - 1 / \\
& 20.22095 * (0.1676 * T312 + 0.1529 * T322 + 0.4029 * T332 + 0.2637 * T342 + 0.0129 * T352) < 0; \\
& 1 / 20.22095 * (0.1676 * T312 + 0.1529 * T322 + 0.4029 * T332 + 0.2637 * T342 + 0.0129 * T352) - 1 / \\
& 3.12405 * (0.611 * T716 + 0.3211 * T726 + 0.0679 * T736) < 0; \\
& 1 / 3.12405 * (0.611 * T716 + 0.3211 * T726 + 0.0679 * T736) - 1 / 3.12405 * (0.611 * T712 + 0.3211 * \\
& T722 + 0.0679 * T732) < 0; \\
& 1 / 3.12405 * (0.611 * T712 + 0.3211 * T722 + 0.0679 * T732) - 1 / 11.26295 * (0.2871 * T211 + \\
& 0.2649 * T221 + 0.4057 * T231 + 0.0423 * T241) < 0; \\
& 1 / 11.26295 * (0.2871 * T211 + 0.2649 * T221 + 0.4057 * T231 + 0.0423 * T241) - 1 / 23.86835 * (\\
& 0.2636 * T511 + 0.0797 * T521 + 0.2058 * T531 + 0.387 * T541 + 0.0639 * T551) < 0; \\
& 1 / 23.86835 * (0.2636 * T511 + 0.0797 * T521 + 0.2058 * T531 + 0.387 * T541 + 0.0639 * T551) - 1 / \\
& 29.489045 * (0.1774 * T611 + 0.02419 * T621 + 0.1774 * T631 + 0.5726 * T641 + 0.0484 * T651) < 0; \\
& 1 / 29.489045 * (0.1774 * T611 + 0.02419 * T621 + 0.1774 * T631 + 0.5726 * T641 + 0.0484 * T651) - \\
& 1 / 11.26295 * (0.2871 * T215 + 0.2649 * T225 + 0.4057 * T235 + 0.0423 * T245) < 0; \\
& 1 / 11.26295 * (0.2871 * T215 + 0.2649 * T225 + 0.4057 * T235 + 0.0423 * T245) - 1 / 24.836265 * (\\
& 0.266504 * T411 + 0.03423 * T421 + 0.1858 * T431 + 0.4939 * T441 + 0.0196 * T451) < 0; \\
& 1 / 24.836265 * (0.266504 * T411 + 0.03423 * T421 + 0.1858 * T431 + 0.4939 * T441 + 0.0196 * T451) \\
& - 1 / 23.86835 * (0.2636 * T515 + 0.0797 * T525 + 0.2058 * T535 + 0.387 * T545 + 0.0639 * T555) < 0; \\
& 1 / 23.86835 * (0.2636 * T515 + 0.0797 * T525 + 0.2058 * T535 + 0.387 * T545 + 0.0639 * T555) - 1 / \\
& 29.489045 * (0.1774 * T615 + 0.02419 * T625 + 0.1774 * T635 + 0.5726 * T645 + 0.0484 * T655) < 0; \\
& 1 / 29.489045 * (0.1774 * T615 + 0.02419 * T625 + 0.1774 * T635 + 0.5726 * T645 + 0.0484 * T655) - \\
& 1 / 24.836265 * (0.266504 * T415 + 0.03423 * T425 + 0.1858 * T435 + 0.4939 * T445 + 0.0196 * T455) \\
& < 0;
\end{aligned}$$

$$\begin{aligned}
& 1 / 24.836265 * (0.266504 * T415 + 0.03423 * T425 + 0.1858 * T435 + 0.4939 * T445 + 0.0196 * T455) \\
& - 1 / 14.9281 * (0.3522 * T811 + 0.1822 * T821 + 0.247 * T831 + 0.2065 * T841 + 0.0121 * T851) < 0; \\
& 1 / 14.9281 * (0.3522 * T811 + 0.1822 * T821 + 0.247 * T831 + 0.2065 * T841 + 0.0121 * T851) - 1 / \\
& 20.22095 * (0.1676 * T311 + 0.1529 * T321 + 0.4029 * T331 + 0.2637 * T341 + 0.0129 * T351) < 0; \\
& 1 / 20.22095 * (0.1676 * T311 + 0.1529 * T321 + 0.4029 * T331 + 0.2637 * T341 + 0.0129 * T351) - 1 / \\
& 14.9281 * (0.3522 * T815 + 0.1822 * T825 + 0.247 * T835 + 0.2065 * T845 + 0.0121 * T855) < 0; \\
& 1 / 14.9281 * (0.3522 * T815 + 0.1822 * T825 + 0.247 * T835 + 0.2065 * T845 + 0.0121 * T855) - 1 / \\
& 20.22095 * (0.1676 * T315 + 0.1529 * T325 + 0.4029 * T335 + 0.2637 * T345 + 0.0129 * T355) < 0; \\
& 1 / 20.22095 * (0.1676 * T315 + 0.1529 * T325 + 0.4029 * T335 + 0.2637 * T345 + 0.0129 * T355) - 1 / \\
& 3.12405 * (0.611 * T711 + 0.3211 * T721 + 0.0679 * T731) < 0; \\
& 1 / 3.12405 * (0.611 * T711 + 0.3211 * T721 + 0.0679 * T731) - 1 / 3.12405 * (0.611 * T715 + 0.3211 * \\
& T725 + 0.0679 * T735) < 0; \\
& 0.493755 * T111 + 0.007985 * T211 + 0.007368 * T221 + 0.011284 * T231 + 0.001176 * T241 + \\
& 0.000586 * T311 + 0.000535 * T321 + 0.001409 * T331 + 0.000922 * T341 + 0.000045 * T351 + \\
& 0.000109 * T411 + 0.000014 * T421 + 0.000076 * T431 + 0.000202 * T441 + 0.000008 * T451 + \\
& 0.000192 * T511 + 0.000058 * T521 + 0.00015 * T531 + 0.000283 * T541 + 0.000047 * T551 + \\
& 0.000558 * T611 + 0.000076 * T621 + 0.000558 * T631 + 0.001803 * T641 + 0.000152 * T651 + \\
& 0.006154 * T711 + 0.003234 * T721 + 0.000684 * T731 + 0.000293 * T811 + 0.000152 * T821 + \\
& 0.000206 * T831 + 0.000172 * T841 + 0.00001 * T851 = 0.054313; \\
& 3.558514 * T112 + 0.101369 * T212 + 0.093531 * T222 + 0.143245 * T232 + 0.014935 * T242 + \\
& 0.00744 * T312 + 0.006788 * T322 + 0.017886 * T332 + 0.011707 * T342 + 0.000573 * T352 + \\
& 0.001384 * T412 + 0.000178 * T422 + 0.000965 * T432 + 0.002566 * T442 + 0.000102 * T452 + \\
& 0.002443 * T512 + 0.000739 * T522 + 0.001907 * T532 + 0.003587 * T542 + 0.000592 * T552 + \\
& 0.00709 * T612 + 0.000967 * T622 + 0.00709 * T632 + 0.022884 * T642 + 0.001934 * T652 + \\
& 0.078127 * T712 + 0.041058 * T722 + 0.008682 * T732 + 0.003722 * T812 + 0.001925 * T822 + \\
& 0.00261 * T832 + 0.002182 * T842 + 0.000128 * T852 = 0.283112; \\
& 4.956121 * T113 + 0.166993 * T213 + 0.15408 * T223 + 0.235977 * T233 + 0.024604 * T243 + \\
& 0.012257 * T313 + 0.011182 * T323 + 0.029465 * T333 + 0.019285 * T343 + 0.000943 * T353 + \\
& 0.002281 * T413 + 0.000293 * T423 + 0.00159 * T433 + 0.004227 * T443 + 0.000168 * T453 + \\
& 0.004025 * T513 + 0.001217 * T523 + 0.003142 * T533 + 0.005909 * T543 + 0.000976 * T553 + \\
& 0.01168 * T613 + 0.001593 * T623 + 0.01168 * T633 + 0.037699 * T643 + 0.003187 * T653 + \\
& 0.128704 * T713 + 0.067638 * T723 + 0.014303 * T733 + 0.006131 * T813 + 0.003172 * T823 + \\
& 0.0043 * T833 + 0.003595 * T843 + 0.000211 * T853 = 0.214361; \\
& 1.270279 * T114 + 0.039109 * T214 + 0.036085 * T224 + 0.055265 * T234 + 0.005762 * T244 + \\
& 0.002871 * T314 + 0.002619 * T324 + 0.006901 * T334 + 0.004517 * T344 + 0.000221 * T354 + \\
& 0.000534 * T414 + 0.000069 * T424 + 0.000372 * T434 + 0.00099 * T444 + 0.000039 * T454 + \\
& 0.000943 * T514 + 0.000285 * T524 + 0.000736 * T534 + 0.001384 * T544 + 0.000228 * T554 + \\
& 0.002735 * T614 + 0.000373 * T624 + 0.002735 * T634 + 0.008829 * T644 + 0.000746 * T654 + \\
& 0.030142 * T714 + 0.015841 * T724 + 0.00335 * T734 + 0.001436 * T814 + 0.000743 * T824 + \\
& 0.001007 * T834 + 0.000842 * T844 + 0.000049 * T854 = 0.032982; \\
& 0.919051 * T115 + 0.012892 * T215 + 0.011895 * T225 + 0.018217 * T235 + 0.001899 * T245 + \\
& 0.000946 * T315 + 0.000863 * T325 + 0.002275 * T335 + 0.001489 * T345 + 0.000073 * T355 + \\
& 0.000176 * T415 + 0.000023 * T425 + 0.000123 * T435 + 0.000326 * T445 + 0.000013 * T455 + \\
& 0.000311 * T515 + 0.000094 * T525 + 0.000243 * T535 + 0.000456 * T545 + 0.000075 * T555 + \\
& 0.000902 * T615 + 0.000123 * T625 + 0.000902 * T635 + 0.00291 * T645 + 0.000246 * T655 + \\
& 0.009936 * T715 + 0.005222 * T725 + 0.001104 * T735 + 0.000473 * T815 + 0.000245 * T825 + \\
& 0.000332 * T835 + 0.000278 * T845 + 0.000016 * T855 = 0.046182; \\
& 7.618335 * T116 + 0.113587 * T216 + 0.104804 * T226 + 0.16051 * T236 + 0.016735 * T246 + \\
& 0.008337 * T316 + 0.007606 * T326 + 0.020042 * T336 + 0.013118 * T346 + 0.000642 * T356 + \\
& 0.001551 * T416 + 0.000199 * T426 + 0.001082 * T436 + 0.002875 * T446 + 0.000114 * T456 + \\
& 0.002738 * T516 + 0.000828 * T526 + 0.002137 * T536 + 0.004019 * T546 + 0.000664 * T556 + \\
& 0.007944 * T616 + 0.001083 * T626 + 0.007944 * T636 + 0.025643 * T646 + 0.002167 * T656 + \\
& 0.087543 * T716 + 0.046007 * T726 + 0.009729 * T736 + 0.00417 * T816 + 0.002157 * T826 +
\end{aligned}$$

$0.002925 * T836 + 0.002445 * T846 + 0.000143 * T856 = 0.232695;$
 $16.392244 * T117 + 0.316451 * T217 + 0.291981 * T227 + 0.447176 * T237 + 0.046624 * T247 +$
 $0.023227 * T317 + 0.02119 * T327 + 0.055836 * T337 + 0.036545 * T347 + 0.001788 * T357 +$
 $0.004322 * T417 + 0.000555 * T427 + 0.003013 * T437 + 0.00801 * T447 + 0.000318 * T457 +$
 $0.007627 * T517 + 0.002306 * T527 + 0.005954 * T537 + 0.011197 * T547 + 0.001849 * T557 +$
 $0.022133 * T617 + 0.003018 * T627 + 0.022133 * T637 + 0.07144 * T647 + 0.006039 * T657 +$
 $0.243893 * T717 + 0.128173 * T727 + 0.027104 * T737 + 0.011618 * T817 + 0.00601 * T827 +$
 $0.008148 * T837 + 0.006812 * T847 + 0.000399 * T857 = 0.364601;$
 $15.662264 * T118 + 0.478193 * T218 + 0.441217 * T228 + 0.675733 * T238 + 0.070455 * T248 +$
 $0.035098 * T318 + 0.03202 * T328 + 0.084375 * T338 + 0.055224 * T348 + 0.002701 * T358 +$
 $0.006531 * T418 + 0.000839 * T428 + 0.004553 * T438 + 0.012104 * T448 + 0.00048 * T458 +$
 $0.011525 * T518 + 0.003485 * T528 + 0.008998 * T538 + 0.01692 * T548 + 0.002794 * T558 +$
 $0.033446 * T618 + 0.004561 * T628 + 0.033446 * T638 + 0.107953 * T648 + 0.009125 * T658 +$
 $0.36855 * T718 + 0.193685 * T728 + 0.040957 * T738 + 0.017557 * T818 + 0.009082 * T828 +$
 $0.012313 * T838 + 0.010294 * T848 + 0.000603 * T858 = 0.246493;$
 $35.762765 * T119 + 1.058671 * T219 + 0.976809 * T229 + 1.496004 * T239 + 0.15598 * T249 +$
 $0.077704 * T319 + 0.070889 * T329 + 0.186797 * T339 + 0.122259 * T349 + 0.005981 * T359 +$
 $0.014459 * T419 + 0.001857 * T429 + 0.010081 * T439 + 0.026796 * T449 + 0.001063 * T459 +$
 $0.025515 * T519 + 0.007715 * T529 + 0.01992 * T539 + 0.03746 * T549 + 0.006185 * T559 +$
 $0.074045 * T619 + 0.010097 * T629 + 0.074045 * T639 + 0.238998 * T649 + 0.020202 * T659 +$
 $0.815931 * T719 + 0.428798 * T729 + 0.090674 * T739 + 0.038868 * T819 + 0.020107 * T829 +$
 $0.027259 * T839 + 0.022789 * T849 + 0.001335 * T859 = 0.293262;$
 $4 * T221 - T231 < 0.05960956;$
 $T241 - 2 * T231 > 0.188936388;$
 $4 * T321 - T331 < 0.0660888600000001;$
 $T341 - 2 * T331 > 0.254247732;$
 $T351 - 1.375 * T341 > 0.4289231807;$
 $4 * T421 - T431 < 0.114489231;$
 $T441 - 2 * T431 > 0.128873277;$
 $T451 - 1.375 * T441 > 0.283590861875;$
 $4 * T521 - T531 < 0.080278527;$
 $T541 - 2 * T531 > 0.083777349;$
 $T551 - 1.375 * T541 > 0.190418527875;$
 $4 * T621 - T631 < 0.092070853;$
 $T641 - 2 * T631 > 0.10626052;$
 $T651 - 1.375 * T641 > 0.20329127715;$
 $4 * T721 - T731 < 0.413055375;$
 $4 * T821 - T831 < 0.078464323;$
 $T841 - 2 * T831 > 0.400615119;$
 $T851 - 1.375 * T841 > 0.514393246825;$
 $4 * T222 - T232 < 0.0175444;$
 $T242 - 2 * T232 > 0.05560812;$
 $4 * T322 - T332 < 0.0194514;$
 $T342 - 2 * T332 > 0.07483068;$
 $T352 - 1.375 * T342 > 0.126241493;$
 $4 * T422 - T432 < 0.03369669;$
 $T442 - 2 * T432 > 0.03793023;$
 $T452 - 1.375 * T442 > 0.08346700625;$
 $4 * T522 - T532 < 0.02362773;$
 $T542 - 2 * T532 > 0.02465751;$
 $T552 - 1.375 * T542 > 0.05604434625;$
 $4 * T622 - T632 < 0.02709847;$
 $T642 - 2 * T632 > 0.0312748;$
 $T652 - 1.375 * T642 > 0.0598330785;$

$4 * T722 - T732 < 0.12157125;$
 $4 * T822 - T832 < 0.02309377;$
 $T842 - 2 * T832 > 0.11790981;$
 $T852 - 1.375 * T842 > 0.15139720675;$
 $4 * T223 - T233 < 0.00619896;$
 $T243 - 2 * T233 > 0.019648008;$
 $4 * T323 - T333 < 0.00687276000000001;$
 $T343 - 2 * T333 > 0.026439912;$
 $T353 - 1.375 * T343 > 0.0446048862;$
 $4 * T423 - T433 < 0.011906046;$
 $T443 - 2 * T433 > 0.013401882;$
 $T453 - 1.375 * T443 > 0.02949138375;$
 $4 * T523 - T533 < 0.008348382;$
 $T543 - 2 * T533 > 0.008712234;$
 $T553 - 1.375 * T543 > 0.01980213975;$
 $4 * T623 - T633 < 0.009574698;$
 $T643 - 2 * T633 > 0.01105032;$
 $T653 - 1.375 * T643 > 0.0211408119;$
 $4 * T723 - T733 < 0.04295475;$
 $4 * T823 - T833 < 0.008159718;$
 $T843 - 2 * T833 > 0.041661054;$
 $T853 - 1.375 * T843 > 0.05349315045;$
 $4 * T224 - T234 < 0.0028152;$
 $T244 - 2 * T234 > 0.00892296;$
 $4 * T324 - T334 < 0.0031212;$
 $T344 - 2 * T334 > 0.01200744;$
 $T354 - 1.375 * T344 > 0.020256894;$
 $4 * T424 - T434 < 0.00540702;$
 $T444 - 2 * T434 > 0.00608634;$
 $T454 - 1.375 * T444 > 0.0133932375;$
 $4 * T524 - T534 < 0.00379134;$
 $T544 - 2 * T534 > 0.00395658;$
 $T554 - 1.375 * T544 > 0.0089929575;$
 $4 * T624 - T634 < 0.00434826;$
 $T644 - 2 * T634 > 0.0050184;$
 $T654 - 1.375 * T644 > 0.009600903;$
 $4 * T724 - T734 < 0.0195075;$
 $4 * T824 - T834 < 0.00370566;$
 $T844 - 2 * T834 > 0.01891998;$
 $T854 - 1.375 * T844 > 0.0242934165;$
 $4 * T225 - T235 < 0.06860164;$
 $T245 - 2 * T235 > 0.217437372;$
 $4 * T325 - T335 < 0.07605834;$
 $T345 - 2 * T335 > 0.292600908;$
 $T355 - 1.375 * T345 > 0.4936260833;$
 $4 * T425 - T435 < 0.131759889;$
 $T445 - 2 * T435 > 0.148313763;$
 $T455 - 1.375 * T445 > 0.326370438125;$
 $4 * T525 - T535 < 0.092388513;$
 $T545 - 2 * T535 > 0.096415131;$
 $T555 - 1.375 * T545 > 0.219143092125;$
 $4 * T625 - T635 < 0.105959707;$
 $T645 - 2 * T635 > 0.12228988;$
 $T655 - 1.375 * T645 > 0.23395769085;$
 $4 * T725 - T735 < 0.475364625;$

4 * T825 - T835 < 0.090300637;
 T845 - 2 * T835 > 0.461047761;
 T855 - 1.375 * T845 > 0.591989277175;
 4 * T226 - T236 < 0.01479176;
 T246 - 2 * T236 > 0.046883448;
 4 * T326 - T336 < 0.01639956;
 T346 - 2 * T336 > 0.063090072;
 T356 - 1.375 * T346 > 0.1064347522;
 4 * T426 - T436 < 0.028409826;
 T446 - 2 * T436 > 0.031979142;
 T456 - 1.375 * T446 > 0.07037139625;
 4 * T526 - T536 < 0.019920642;
 T546 - 2 * T536 > 0.020788854;
 T556 - 1.375 * T546 > 0.04725123225;
 4 * T626 - T636 < 0.022846838;
 T646 - 2 * T636 > 0.02636792;
 T656 - 1.375 * T646 > 0.0504455289;
 4 * T726 - T736 < 0.10249725;
 4 * T826 - T836 < 0.019470458;
 T846 - 2 * T836 > 0.099410274;
 T856 - 1.375 * T846 > 0.12764364395;
 4 * T227 - T237 < 0.00553196;
 T247 - 2 * T237 > 0.017533908;
 4 * T327 - T337 < 0.00613326;
 T347 - 2 * T337 > 0.023595012;
 T357 - 1.375 * T347 > 0.0398054587;
 4 * T427 - T437 < 0.010624971;
 T447 - 2 * T437 > 0.011959857;
 T457 - 1.375 * T447 > 0.026318149375;
 4 * T527 - T537 < 0.007450107;
 T547 - 2 * T537 > 0.007774809;
 T557 - 1.375 * T547 > 0.017671455375;
 4 * T627 - T637 < 0.008544473;
 T647 - 2 * T637 > 0.00986132;
 T657 - 1.375 * T647 > 0.01886608815;
 4 * T727 - T737 < 0.038332875;
 4 * T827 - T837 < 0.007281743;
 T847 - 2 * T837 > 0.037178379;
 T857 - 1.375 * T847 > 0.047737357325;
 4 * T228 - T238 < 0.00271124;
 T248 - 2 * T238 > 0.008593452;
 4 * T328 - T338 < 0.00300594;
 T348 - 2 * T338 > 0.011564028;
 T358 - 1.375 * T348 > 0.0195088453;
 4 * T428 - T438 < 0.005207349;
 T448 - 2 * T438 > 0.005861583;
 T458 - 1.375 * T448 > 0.012898650625;
 4 * T528 - T538 < 0.003651333;
 T548 - 2 * T538 > 0.003810471;
 T558 - 1.375 * T548 > 0.008660864625;
 4 * T628 - T638 < 0.004187687;
 T648 - 2 * T638 > 0.00483308;
 T658 - 1.375 * T648 > 0.00924635985;
 4 * T728 - T738 < 0.018787125;
 4 * T828 - T838 < 0.003568817;

$T848 - 2 * T838 > 0.018221301;$
 $T858 - 1.375 * T848 > 0.023396306675;$
 $4 * T229 - T239 < 0.00137172;$
 $T249 - 2 * T239 > 0.004347756;$
 $4 * T329 - T339 < 0.00152082;$
 $T349 - 2 * T339 > 0.005850684;$
 $T359 - 1.375 * T349 > 0.00987027090000001;$
 $4 * T429 - T439 < 0.002634597;$
 $T449 - 2 * T439 > 0.002965599;$
 $T459 - 1.375 * T449 > 0.006525920625;$
 $4 * T529 - T539 < 0.001847349;$
 $T549 - 2 * T539 > 0.001927863;$
 $T559 - 1.375 * T549 > 0.004381862625;$
 $4 * T629 - T639 < 0.002118711;$
 $T649 - 2 * T639 > 0.00244524;$
 $T659 - 1.375 * T649 > 0.00467808705;$
 $4 * T729 - T739 < 0.009505125;$
 $4 * T829 - T839 < 0.001805601;$
 $T849 - 2 * T839 > 0.009218853;$
 $T859 - 1.375 * T849 > 0.011837086275;$
 $T111 = 0.069301;$
 $T112 = 0.050125;$
 $T113 = 0.027251;$
 $T114 = 0.016363;$
 $T115 \leq 0.031663;$
 $T116 = 0.019244;$
 $T117 = 0.014017;$
 $T118 = 0.00992;$
 $T119 = 0.005168;$
 $@BND(0.0000064793, T111, 10) ;$
 $@BND(0.04017166, T211, 10) ;$
 $@BND(0.051575228, T221, 10) ;$
 $@BND(0.146691352, T231, 10) ;$
 $@BND(0.482319092, T241, 10) ;$
 $@BND(0.04859475, T311, 10) ;$
 $@BND(0.07192023, T321, 10) ;$
 $@BND(0.22159206, T331, 10) ;$
 $@BND(0.697431852, T341, 10) ;$
 $@BND(1.318148792, T351, 10) ;$
 $@BND(0.052676709, T411, 10) ;$
 $@BND(0.06932851, T421, 10) ;$
 $@BND(0.162824809, T431, 10) ;$
 $@BND(0.454522895, T441, 10) ;$
 $@BND(0.863107553, T451, 10) ;$
 $@BND(0.042245036, T511, 10) ;$
 $@BND(0.059285595, T521, 10) ;$
 $@BND(0.156863853, T531, 10) ;$
 $@BND(0.397505055, T541, 10) ;$
 $@BND(0.697237473, T551, 10) ;$
 $@BND(0.044383205, T611, 10) ;$
 $@BND(0.06090542, T621, 10) ;$
 $@BND(0.151550827, T631, 10) ;$
 $@BND(0.409362174, T641, 10) ;$
 $@BND(0.725228049, T651, 10) ;$

@BND(0.007192023, T711, 10) ;
@BND(0.042245036, T721, 10) ;
@BND(0.582035519, T731, 10) ;
@BND(0.007451195, T811, 10) ;
@BND(0.016716594, T821, 10) ;
@BND(0.145330699, T831, 10) ;
@BND(0.691276517, T841, 10) ;
@BND(1.395770806, T851, 10) ;
@BND(0.000001907, T112, 10) ;
@BND(0.0118234, T212, 10) ;
@BND(0.01517972, T222, 10) ;
@BND(0.04317448, T232, 10) ;
@BND(0.14195708, T242, 10) ;
@BND(0.0143025, T312, 10) ;
@BND(0.0211677, T322, 10) ;
@BND(0.0652194, T332, 10) ;
@BND(0.20526948, T342, 10) ;
@BND(0.38796008, T352, 10) ;
@BND(0.01550391, T412, 10) ;
@BND(0.0204049, T422, 10) ;
@BND(0.04792291, T432, 10) ;
@BND(0.13377605, T442, 10) ;
@BND(0.25403147, T452, 10) ;
@BND(0.01243364, T512, 10) ;
@BND(0.01744905, T522, 10) ;
@BND(0.04616847, T532, 10) ;
@BND(0.11699445, T542, 10) ;
@BND(0.20521227, T552, 10) ;
@BND(0.01306295, T612, 10) ;
@BND(0.0179258, T622, 10) ;
@BND(0.04460473, T632, 10) ;
@BND(0.12048426, T642, 10) ;
@BND(0.21345051, T652, 10) ;
@BND(0.00211677, T712, 10) ;
@BND(0.01243364, T722, 10) ;
@BND(0.17130581, T732, 10) ;
@BND(0.00219305, T812, 10) ;
@BND(0.00492006, T822, 10) ;
@BND(0.04277401, T832, 10) ;
@BND(0.20345783, T842, 10) ;
@BND(0.41080594, T852, 10) ;
@BND(0.0000006738, T113, 10) ;
@BND(0.00417756, T213, 10) ;
@BND(0.005363448, T223, 10) ;
@BND(0.015254832, T233, 10) ;
@BND(0.050157672, T243, 10) ;
@BND(0.0050535, T313, 10) ;
@BND(0.00747918, T323, 10) ;
@BND(0.02304396, T333, 10) ;
@BND(0.072527832, T343, 10) ;
@BND(0.137077872, T353, 10) ;
@BND(0.005477994, T413, 10) ;
@BND(0.00720966, T423, 10) ;
@BND(0.016932594, T433, 10) ;
@BND(0.04726707, T443, 10) ;

@BND(0.089756898, T453, 10) ;
@BND(0.004393176, T513, 10) ;
@BND(0.00616527, T523, 10) ;
@BND(0.016312698, T533, 10) ;
@BND(0.04133763, T543, 10) ;
@BND(0.072507618, T553, 10) ;
@BND(0.00461553, T613, 10) ;
@BND(0.00633372, T623, 10) ;
@BND(0.015760182, T633, 10) ;
@BND(0.042570684, T643, 10) ;
@BND(0.075418434, T653, 10) ;
@BND(0.000747918, T713, 10) ;
@BND(0.004393176, T723, 10) ;
@BND(0.060527454, T733, 10) ;
@BND(0.00077487, T813, 10) ;
@BND(0.001738404, T823, 10) ;
@BND(0.015113334, T833, 10) ;
@BND(0.071887722, T843, 10) ;
@BND(0.145149996, T853, 10) ;
@BND(0.000000306, T114, 10) ;
@BND(0.0018972, T214, 10) ;
@BND(0.00243576, T224, 10) ;
@BND(0.00692784, T234, 10) ;
@BND(0.02277864, T244, 10) ;
@BND(0.002295, T314, 10) ;
@BND(0.0033966, T324, 10) ;
@BND(0.0104652, T334, 10) ;
@BND(0.03293784, T344, 10) ;
@BND(0.06225264, T354, 10) ;
@BND(0.00248778, T414, 10) ;
@BND(0.0032742, T424, 10) ;
@BND(0.00768978, T434, 10) ;
@BND(0.0214659, T444, 10) ;
@BND(0.04076226, T454, 10) ;
@BND(0.00199512, T514, 10) ;
@BND(0.0027999, T524, 10) ;
@BND(0.00740826, T534, 10) ;
@BND(0.0187731, T544, 10) ;
@BND(0.03292866, T554, 10) ;
@BND(0.0020961, T614, 10) ;
@BND(0.0028764, T624, 10) ;
@BND(0.00715734, T634, 10) ;
@BND(0.01933308, T644, 10) ;
@BND(0.03425058, T654, 10) ;
@BND(0.00033966, T714, 10) ;
@BND(0.00199512, T724, 10) ;
@BND(0.02748798, T734, 10) ;
@BND(0.0003519, T814, 10) ;
@BND(0.00078948, T824, 10) ;
@BND(0.00686358, T834, 10) ;
@BND(0.03264714, T844, 10) ;
@BND(0.06591852, T854, 10) ;
@BND(0.0000074567, T115, 10) ;
@BND(0.04623154, T215, 10) ;
@BND(0.059355332, T225, 10) ;

@BND(0.168819688, T235, 10) ;
@BND(0.555076748, T245, 10) ;
@BND(0.05592525, T315, 10) ;
@BND(0.08276937, T325, 10) ;
@BND(0.25501914, T335, 10) ;
@BND(0.802639188, T345, 10) ;
@BND(1.516991048, T355, 10) ;
@BND(0.060622971, T415, 10) ;
@BND(0.07978669, T425, 10) ;
@BND(0.187386871, T435, 10) ;
@BND(0.523087505, T445, 10) ;
@BND(0.993307007, T455, 10) ;
@BND(0.048617684, T515, 10) ;
@BND(0.068228805, T525, 10) ;
@BND(0.180526707, T535, 10) ;
@BND(0.457468545, T545, 10) ;
@BND(0.802415487, T555, 10) ;
@BND(0.051078395, T615, 10) ;
@BND(0.07009298, T625, 10) ;
@BND(0.174412213, T635, 10) ;
@BND(0.471114306, T645, 10) ;
@BND(0.834628431, T655, 10) ;
@BND(0.008276937, T715, 10) ;
@BND(0.048617684, T725, 10) ;
@BND(0.669835361, T735, 10) ;
@BND(0.008575205, T815, 10) ;
@BND(0.019238286, T825, 10) ;
@BND(0.167253781, T835, 10) ;
@BND(0.795555323, T845, 10) ;
@BND(1.606322314, T855, 10) ;
@BND(0.0000016078, T116, 10) ;
@BND(0.00996836, T216, 10) ;
@BND(0.012798088, T226, 10) ;
@BND(0.036400592, T236, 10) ;
@BND(0.119684632, T246, 10) ;
@BND(0.0120585, T316, 10) ;
@BND(0.01784658, T326, 10) ;
@BND(0.05498676, T336, 10) ;
@BND(0.173063592, T346, 10) ;
@BND(0.327090832, T356, 10) ;
@BND(0.013071414, T416, 10) ;
@BND(0.01720346, T426, 10) ;
@BND(0.040404014, T436, 10) ;
@BND(0.11278717, T446, 10) ;
@BND(0.214175038, T456, 10) ;
@BND(0.010482856, T516, 10) ;
@BND(0.01471137, T526, 10) ;
@BND(0.038924838, T536, 10) ;
@BND(0.09863853, T546, 10) ;
@BND(0.173015358, T556, 10) ;
@BND(0.01101343, T616, 10) ;
@BND(0.01511332, T626, 10) ;
@BND(0.037606442, T636, 10) ;
@BND(0.101580804, T646, 10) ;
@BND(0.179961054, T656, 10) ;

@BND(0.001784658, T716, 10) ;
@BND(0.010482856, T726, 10) ;
@BND(0.144428674, T736, 10) ;
@BND(0.00184897, T816, 10) ;
@BND(0.004148124, T826, 10) ;
@BND(0.036062954, T836, 10) ;
@BND(0.171536182, T846, 10) ;
@BND(0.346352276, T856, 10) ;
@BND(0.000006013, T117, 10) ;
@BND(0.00372806, T217, 10) ;
@BND(0.004786348, T227, 10) ;
@BND(0.013613432, T237, 10) ;
@BND(0.044760772, T247, 10) ;
@BND(0.00450975, T317, 10) ;
@BND(0.00667443, T327, 10) ;
@BND(0.02056446, T337, 10) ;
@BND(0.064723932, T347, 10) ;
@BND(0.122328472, T357, 10) ;
@BND(0.004888569, T417, 10) ;
@BND(0.00643391, T427, 10) ;
@BND(0.015110669, T437, 10) ;
@BND(0.042181195, T447, 10) ;
@BND(0.080099173, T457, 10) ;
@BND(0.003920476, T517, 10) ;
@BND(0.005501895, T527, 10) ;
@BND(0.014557473, T537, 10) ;
@BND(0.036889755, T547, 10) ;
@BND(0.064705893, T557, 10) ;
@BND(0.004118905, T617, 10) ;
@BND(0.00565222, T627, 10) ;
@BND(0.014064407, T637, 10) ;
@BND(0.037990134, T647, 10) ;
@BND(0.067303509, T657, 10) ;
@BND(0.000667443, T717, 10) ;
@BND(0.003920476, T727, 10) ;
@BND(0.054014779, T737, 10) ;
@BND(0.000691495, T817, 10) ;
@BND(0.001551354, T827, 10) ;
@BND(0.013487159, T837, 10) ;
@BND(0.064152697, T847, 10) ;
@BND(0.129532046, T857, 10) ;
@BND(0.0000002947, T118, 10) ;
@BND(0.00182714, T218, 10) ;
@BND(0.002345812, T228, 10) ;
@BND(0.006672008, T238, 10) ;
@BND(0.021937468, T248, 10) ;
@BND(0.00221025, T318, 10) ;
@BND(0.00327117, T328, 10) ;
@BND(0.01007874, T338, 10) ;
@BND(0.031721508, T348, 10) ;
@BND(0.059953768, T358, 10) ;
@BND(0.002395911, T418, 10) ;
@BND(0.00315329, T428, 10) ;
@BND(0.007405811, T438, 10) ;
@BND(0.020673205, T448, 10) ;

@BND(0.039256987, T458, 10) ;
@BND(0.001921444, T518, 10) ;
@BND(0.002696505, T528, 10) ;
@BND(0.007134687, T538, 10) ;
@BND(0.018079845, T548, 10) ;
@BND(0.031712667, T558, 10) ;
@BND(0.002018695, T618, 10) ;
@BND(0.00277018, T628, 10) ;
@BND(0.006893033, T638, 10) ;
@BND(0.018619146, T648, 10) ;
@BND(0.032985771, T658, 10) ;
@BND(0.000327117, T718, 10) ;
@BND(0.001921444, T728, 10) ;
@BND(0.026472901, T738, 10) ;
@BND(0.000338905, T818, 10) ;
@BND(0.000760326, T828, 10) ;
@BND(0.006610121, T838, 10) ;
@BND(0.031441543, T848, 10) ;
@BND(0.063484274, T858, 10) ;
@BND(0.0000001491, T119, 10) ;
@BND(0.00092442, T219, 10) ;
@BND(0.001186836, T229, 10) ;
@BND(0.003375624, T239, 10) ;
@BND(0.011099004, T249, 10) ;
@BND(0.00111825, T319, 10) ;
@BND(0.00165501, T329, 10) ;
@BND(0.00509922, T339, 10) ;
@BND(0.016049124, T349, 10) ;
@BND(0.030332904, T359, 10) ;
@BND(0.001212183, T419, 10) ;
@BND(0.00159537, T429, 10) ;
@BND(0.003746883, T439, 10) ;
@BND(0.010459365, T449, 10) ;
@BND(0.019861611, T459, 10) ;
@BND(0.000972132, T519, 10) ;
@BND(0.001364265, T529, 10) ;
@BND(0.003609711, T539, 10) ;
@BND(0.009147285, T549, 10) ;
@BND(0.016044651, T559, 10) ;
@BND(0.001021335, T619, 10) ;
@BND(0.00140154, T629, 10) ;
@BND(0.003487449, T639, 10) ;
@BND(0.009420138, T649, 10) ;
@BND(0.016688763, T659, 10) ;
@BND(0.000165501, T719, 10) ;
@BND(0.000972132, T729, 10) ;
@BND(0.013393653, T739, 10) ;
@BND(0.000171465, T819, 10) ;
@BND(0.000384678, T829, 10) ;
@BND(0.003344313, T839, 10) ;
@BND(0.015907479, T849, 10) ;
@BND(0.032119122, T859, 10) ;

END

IMAGE EVALUATION TEST TARGET (QA-3)

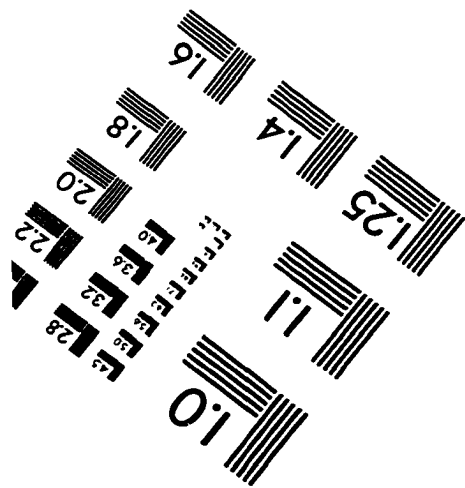
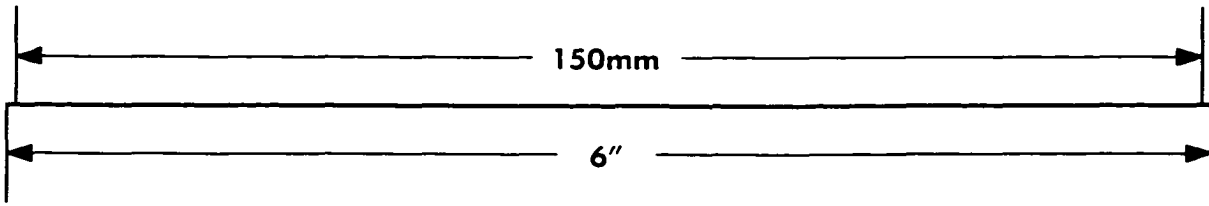
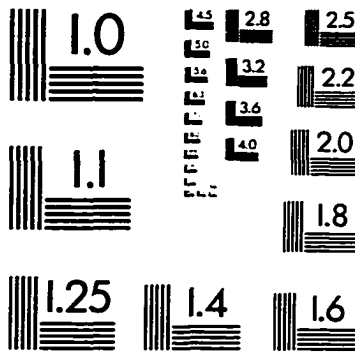
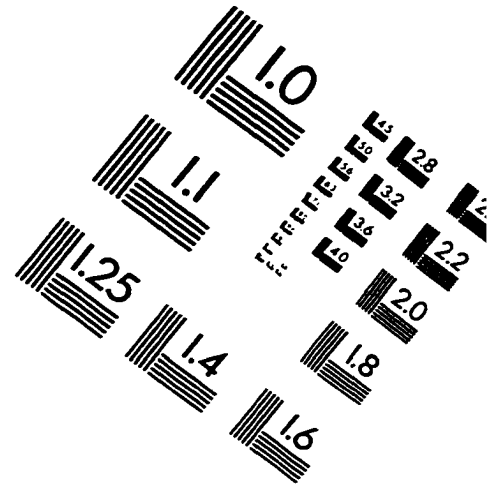
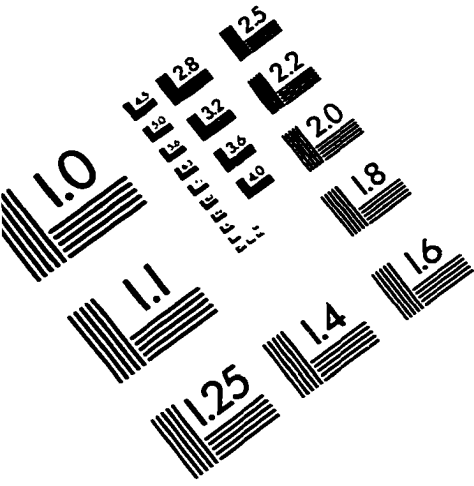

APPLIED IMAGE, Inc
 1653 East Main Street
 Rochester, NY 14609 USA
 Phone: 716/482-0300
 Fax: 716/288-5989

© 1993, Applied Image, Inc., All Rights Reserved

